

Errata

Title & Document Type: 11759C RF Channel Simulator Operating and Service Manual

Manual Part Number: 11759-90016

Revision Date: February 1993

HP References in this Manual

This manual may contain references to HP or Hewlett-Packard. Please note that Hewlett-Packard's former test and measurement, semiconductor products and chemical analysis businesses are now part of Agilent Technologies. We have made no changes to this manual copy. The HP XXXX referred to in this document is now the Agilent XXXX. For example, model number HP8648A is now model number Agilent 8648A.

About this Manual

We've added this manual to the Agilent website in an effort to help you support your product. This manual provides the best information we could find. It may be incomplete or contain dated information, and the scan quality may not be ideal. If we find a better copy in the future, we will add it to the Agilent website.

Support for Your Product

Agilent no longer sells or supports this product. You will find any other available product information on the Agilent Test & Measurement website:

www.tm.agilent.com

Search for the model number of this product, and the resulting product page will guide you to any available information. Our service centers may be able to perform calibration if no repair parts are needed, but no other support from Agilent is available.

HP 11759C (Including options 001, 002, and 003) RF Channel Simulator Operating and Service Manual

SERIAL NUMBERS

Attached to the rear panel of the instrument is a serial number plate. The serial number is in the form: 0000A00000. The first four digits and the letter are the serial number prefix. The last five digits are the suffix. The prefix is the same for identical instruments; it changes only when a configuration change is made to the instrument. The suffix, however, is assigned sequentially and is different for each instrument.

This manual applies to instruments with serial numbers prefixed 3250A and above.



HP Part No. 11759-90016

**© HEWLETT-PACKARD COMPANY 1993
5301 Stevens Creek Blvd., Santa Clara, California
Printed in USA**

Safety Considerations

This product and related documentation must be reviewed for familiarization with safety markings and instructions before operation.

This product is a Safety Class I instrument (provided with a protective earth terminal).

Before Applying Power

Verify that the product is set to match the available line voltage and the correct fuse is installed.

Safety Earth Ground

An uninterruptable safety earth ground must be provided from the main power source to the product input wiring terminals, power cable, or supplied power cable set.

Warning



Any interruption of the protective (grounding) conductor (inside or outside the instrument) or disconnecting the protective earth terminal will cause a potential shock hazard that could result in personal injury. (Grounding one conductor of a two conductor outlet is not sufficient protection.) In addition, verify that a common ground exists between the unit under test and the instrument prior to energizing either unit.

Whenever it is likely that the protection has been impaired, the instrument must be made inoperative and be secured against any unintended operation.

If this instrument is to be energized via an autotransformer (for voltage reduction) make sure the common terminal is connected to neutral (that is, the grounded side of the mains supply.)

Exceptions: The secondary of the isolation transformer in the HP Frequency Agile Signal Simulator (HP FASS) system cabinet is floating. This means that if you measure either side of the secondary to chassis ground, it would measure approximately one-half the line voltage. An example would be if the mains were at 120 V ac, it would measure approximately 60 V ac at the secondary from neutral to chassis ground or from the hot side to ground.

It is recommended that when working on any units within the HP FASS system, that the unit be worked on at a work bench and powered with the mains available at the bench.

Servicing instructions are for use by service-trained personnel only. To avoid dangerous electric shock, do not perform any servicing unless qualified to do so.

Adjustments described in this manual are performed with power supplied to the instrument while protective covers are removed. Energy available at many points may, if contacted, result in personal injury.

Capacitors inside the instrument might still be charged even if the instrument has been disconnected from its source of supply.

For continued protection against fire hazard, replace the line fuses only with 250V fuses of the same current rating and type (for example, normal blow, time delay, etc.). Do not use repaired fuses or short circuited fuse holders.

Safety Symbols



Instruction manual symbol: The product will be marked with this symbol when it is necessary for the user to refer to the instruction manual (see Table of Contents for page references).



Indicates hazardous voltages.



Indicates earth (ground) terminal.

Warning



The **WARNING** sign denotes a hazard. It calls attention to a procedure, practice, or the like, which, if not correctly performed or adhered to, could result in personal injury. Do not proceed beyond a **WARNING** sign until the indicated conditions are fully understood and met.

Caution



The **CAUTION** sign denotes a hazard. It calls attention to a procedure, practice, or the like which, if not correctly performed or adhered to, could result in damage to or destruction of part or all of the product. Do not proceed beyond a **CAUTION** sign until the indicated conditions are fully understood and met.

Contents

| | |
|--|------|
| 1. General Information | |
| 1-1. Introduction | 1-1 |
| 1-2. Specifications | 1-3 |
| 1-3. Description | 1-3 |
| 1-4. Minimum System Configuration | 1-4 |
| 1-5. Safety Considerations | 1-5 |
| 1-6. Instruments Covered By This Manual | 1-5 |
| 1-7. Manual Changes Supplement | 1-5 |
| 1-8. Options | 1-6 |
| 1-9. Accessories Supplied | 1-6 |
| 1-10. Recommended Test Equipment | 1-7 |
| 2. Installation/Verification | |
| 2-1. Introduction | 2-1 |
| 2-2. Initial Inspection | 2-1 |
| 2-3. Preparation for Use | 2-1 |
| Power Requirement | 2-1 |
| Line Voltage and Fuse Selection | 2-2 |
| Power Cables | 2-3 |
| Mating Connectors | 2-4 |
| Interconnections | 2-4 |
| Operating Environment | 2-4 |
| 2-4. Set-Up and Turn-On Procedures | 2-5 |
| Software Removal | 2-8 |
| 2-5. Installing Remote Control | 2-9 |
| 2-6. System Verification Check | 2-14 |
| Description | 2-14 |
| Equipment | 2-14 |
| Procedure | 2-14 |
| 2-7. Storage and Shipment | 2-18 |
| Environment | 2-18 |
| Packaging | 2-18 |
| 3. Operation | |
| 3-1. Introduction | 3-1 |
| 3-2. Operating Characteristics | 3-1 |
| 3-3. Panel Features | 3-1 |
| 3-4. Operator's Maintenance | 3-1 |
| 3-5. Operating Instructions | 3-2 |
| 3-6. Local Operating Procedures | 3-5 |
| Effect of Local Oscillator and Image Signals Upon Bit Error | 3-8 |

| | |
|---|------|
| 3-7. Simulation Tests | 3-8 |
| 3-8. Travel Test | 3-15 |
| 3-9. Dynamic Test | 3-23 |
| File Format | 3-23 |
| .ASC File Line Format Requirements | 3-26 |
| Characteristics of Operation | 3-27 |
| Translation of ASCII.ASC files to Dynamic Test .DAT files | 3-32 |
| Configuration Compatibility | 3-35 |
| Dynamic Test Simulation | 3-36 |
| Update Rate | 3-38 |
| Additional Applications | 3-40 |
| 3-10. IQMAKE | 3-41 |
| 3-11. HP-IB Remote Operating Procedures | 3-45 |
| Command Types | 3-45 |
| Common Command Format | 3-45 |
| SCPI Command Format | 3-45 |
| Command Separator | 3-46 |
| Abbreviated Commands | 3-46 |
| Implied Commands | 3-46 |
| Sending Remote Commands | 3-47 |
| Parameters | 3-48 |
| PROGram | 3-49 |
| Subsystem Syntax | 3-49 |
| :NAME | 3-49 |
| Parameters | 3-49 |
| Example | 3-49 |
| Comments | 3-49 |
| :NAME? | 3-50 |
| Example | 3-50 |
| Comments | 3-50 |
| :STATe | 3-50 |
| Parameters | 3-50 |
| Example | 3-50 |
| Comments | 3-50 |
| MMEMory | 3-51 |
| Subsystem Syntax | 3-51 |
| :CATalog? | 3-51 |
| Example | 3-51 |
| Comments | 3-51 |
| :LOAD:STATe | 3-52 |
| Parameters | 3-52 |
| Example | 3-52 |
| Comments | 3-52 |
| :LOAD:TRACe | 3-53 |
| Parameters | 3-53 |
| Example | 3-53 |
| Comments | 3-53 |
| :STORe:STATe | 3-54 |
| Parameters | 3-54 |
| Example | 3-54 |

| | |
|-------------------------------|------|
| Comments | 3-54 |
| SMODifier | 3-55 |
| Subsystem Syntax | 3-55 |
| :ATTenuation | 3-56 |
| Parameters | 3-56 |
| Example | 3-56 |
| Comments | 3-56 |
| :ATTenuation? | 3-57 |
| Parameters | 3-57 |
| Example | 3-57 |
| Comments | 3-57 |
| :DELay | 3-58 |
| Parameters | 3-58 |
| Example | 3-58 |
| Comments | 3-58 |
| :DELay:RESolution | 3-59 |
| Parameters | 3-59 |
| Example | 3-59 |
| Comments | 3-59 |
| DELay:RESolution? | 3-60 |
| Parameters | 3-60 |
| Example | 3-60 |
| Comments | 3-60 |
| :DELay? | 3-61 |
| Parameters | 3-61 |
| Example | 3-61 |
| Comments | 3-61 |
| :DOPPler:FREQuency | 3-62 |
| Parameters | 3-62 |
| Example | 3-62 |
| Comments | 3-62 |
| :DOPPler:FREQuency? | 3-63 |
| Parameters | 3-63 |
| Example | 3-63 |
| Comments | 3-63 |
| :LO:FREQuency | 3-64 |
| Parameters | 3-64 |
| Example | 3-64 |
| Comments | 3-64 |
| :LO:FREQuency? | 3-65 |
| Parameters | 3-65 |
| Example | 3-65 |
| Comments | 3-65 |
| :RF:FREQuency | 3-66 |
| Parameters | 3-66 |
| Example | 3-66 |
| Comments | 3-66 |
| :RF:FREQuency? | 3-67 |
| Parameters | 3-67 |
| Example | 3-67 |
| Comments | 3-67 |

| | |
|---------------------|------|
| :PHASe[:ADJust] | 3-68 |
| Parameters | 3-68 |
| Example | 3-68 |
| Comments | 3-68 |
| :PHASe[:ADJust]? | 3-69 |
| Parameters | 3-69 |
| Example | 3-69 |
| Comments | 3-69 |
| :CORRelation | 3-70 |
| Parameters | 3-70 |
| Example | 3-70 |
| Comments | 3-70 |
| :CORRelation:MODE | 3-71 |
| Parameters | 3-71 |
| Example | 3-71 |
| Comments | 3-71 |
| :CORRelation:MODE? | 3-72 |
| Parameters | 3-72 |
| Example | 3-72 |
| Comments | 3-72 |
| :CORRelation? | 3-73 |
| Parameters | 3-73 |
| Example | 3-73 |
| Comments | 3-73 |
| :RAYLeigh:FILEName | 3-74 |
| Parameters | 3-74 |
| Example | 3-74 |
| Comments | 3-74 |
| :RAYLeigh:FILEName? | 3-75 |
| Parameters | 3-75 |
| Example | 3-75 |
| Comments | 3-75 |
| :SPECTrum[:TYPE] | 3-76 |
| Parameters | 3-76 |
| Example | 3-76 |
| Comments | 3-76 |
| :SPECTrum:[TYPE]? | 3-77 |
| Parameters | 3-77 |
| Example | 3-77 |
| Comments | 3-77 |
| SYSTEM | 3-78 |
| Subsystem Syntax | 3-78 |
| :ERRor? | 3-78 |
| Example | 3-78 |
| Comments | 3-78 |
| :PRESet | 3-79 |
| Example | 3-79 |
| Comments | 3-79 |
| :VERSion? | 3-79 |
| Example | 3-79 |
| Comments | 3-79 |

| | |
|---|------|
| Common Commands | 3-80 |
| 3-12. Serial Remote Operating Procedures | 3-81 |
| Remote Operation | 3-81 |
| Word Commands | 3-81 |
| Word Command Programming | 3-81 |
| Single-key Command Programming | 3-82 |
| Sending Remote Commands | 3-82 |
| Notation | 3-82 |
| Syntax | 3-82 |
| Main Menu Word Commands | 3-83 |
| Simulation Test Word Commands | 3-84 |
| Travel Test Word Commands | 3-87 |
| Single-Key Commands | 3-87 |
| Error/Warning Messages | 3-88 |
| | |
| 4. Performance Tests | |
| 4-1. Introduction | 4-1 |
| | |
| 5. Adjustments | |
| 5-1. Introduction | 5-1 |
| 5-2. Safety Considerations | 5-1 |
| 5-3. Equipment Required | 5-1 |
| 5-4. Adjustment Procedure | 5-1 |
| Equipment | 5-1 |
| Procedure | 5-2 |
| | |
| 6. Replaceable Parts | |
| 6-1. Introduction | 6-1 |
| 6-2. Abbreviations | 6-1 |
| 6-3. Replaceable Parts | 6-1 |
| 6-4. Parts List Updating | 6-1 |
| 6-5. Ordering Information | 6-1 |
| | |
| 7. Manual Changes | |
| 7-1. Introduction | 7-1 |
| | |
| 8. Service | |
| 8-1. Introduction | 8-1 |
| 8-2. Safety Considerations | 8-1 |
| Before Applying Power | 8-1 |
| Warnings and Cautions | 8-1 |
| After Service Safety Checks | 8-2 |
| 8-3. Equipment Required | 8-2 |
| 8-4. Service Tools, Aids, and Information | 8-3 |
| Required Service Tools | 8-3 |
| Hardware Characteristics | 8-3 |
| 8-5. Principles of Operation | 8-4 |
| 8-6. Troubleshooting | 8-7 |
| 8-7. Determining The Failure Mode | 8-7 |
| 8-8. Assembly Verification Procedures | 8-9 |
| Verify Path | 8-9 |

| | |
|---|------|
| Verify Synchronizer | 8-10 |
| Verify Down Converter | 8-10 |
| Verify Up Converter | 8-11 |
| Verify Clock/Divider | 8-11 |
| Verify Power Supply | 8-12 |
| Verify Overdrive LED | 8-13 |
| Verify PC Interface | 8-13 |
| 8-9. Repair | 8-14 |
| Electrostatic Discharge (ESD) Precautions | 8-14 |
| Bottom Cover | 8-15 |
| Cover Replacement | 8-15 |
| A7/A8 Synchronizer PCA | 8-16 |
| A3 Path Assembly | 8-18 |
| A2 Path Assembly | 8-20 |
| A1 Path Assembly | 8-22 |
| A6 Path Assembly | 8-24 |
| A5 Path Assembly | 8-26 |
| A4 Path Assembly | 8-28 |
| A9 Down Converter PCA (STD/OPT 002) | 8-30 |
| A10 Up Converter PCA (STD/OPT 002) | 8-31 |
| A11 Down Converter PCA (STD/OPT 002) | 8-32 |
| A11 Down Converter PCA (OPT 001/003 ONLY) | 8-33 |
| A12 Up Converter PCA (STD/OPT 002) | 8-34 |
| A12 Up Converter PCA (OPT 001/003 ONLY) | 8-35 |
| A13 Clock/Divider PCA | 8-36 |
| A14 Power Supply | 8-38 |
| 8-10. Periodic Maintenance | 8-39 |
| Cleaning Intervals | 8-39 |
| Cleaning Solution | 8-39 |
| 6-Month Cleaning | 8-39 |
| 12-Month Cleaning | 8-40 |

A. Specifications and Test Equipment

B. Programming Examples

| | |
|----------------------------------|-----|
| Introduction | B-1 |
| Programming Example #1 | B-1 |
| Programming Example #2 | B-7 |

C. Standard Profiles

| | |
|------------------------|-----|
| Introduction | C-1 |
| Profile #1 | C-1 |
| Profile #2 | C-1 |
| Profile #3 | C-1 |
| Profile #4 | C-1 |
| Profile #5 | C-2 |
| Profile #6 | C-2 |
| Profile #7 | C-2 |
| Profile #8 | C-2 |
| Profile #9 | C-2 |
| Profile #10 | C-2 |

| | |
|--|-----|
| D. Dynamic ASCII Data File | |
| Introduction | D-1 |
| Dynamic ASCII Data File Example | D-5 |
| E. Translation Utility Data File | |
| Introduction | E-1 |
| F. Hardware Configuration File | |
| Introduction | F-1 |
| G. Error Message Listings | |
| Introduction | G-1 |
| Category of Error | G-1 |
| Specific Parsing Error Message Numbers | G-2 |

Index

Figures

| | |
|--|------|
| 1-1. HP Model 11759C RF Channel Simulator Accessories and Mechanical Options | 1-2 |
| 1-2. HP Model 11759C Simplified Block Diagram . . . | 1-4 |
| 2-1. Line Voltage and Fuse Selection | 2-2 |
| 2-2. Power Cable and Mains Plug Part Numbers . . . | 2-3 |
| 2-3. Set-up and Turn-On Procedures | 2-5 |
| 2-4. Installing Remote Terminal/Computer Procedures | 2-9 |
| 2-5. System Verification Check Setup | 2-15 |
| 3-1. Front and Rear Panel Connections and Indications | 3-2 |
| 3-2. Simulation System Set-up | 3-5 |
| 5-1. Path to Path Insertion Loss Adjustment Setup . . | 5-2 |
| 6-1. Simulator Assembly Locator | 6-8 |
| 6-2. Cabinet Parts | 6-9 |
| 8-1. Simulator Block Diagram | 8-5 |
| 8-2. A7 and A8 Synchronizer PCA Remove and Replace | 8-17 |
| 8-3. A3 Path Assembly Remove and Replace | 8-19 |
| 8-4. A2 Path Assembly Remove and Replace | 8-21 |
| 8-5. A1 Path Assembly Remove and Replace | 8-23 |
| 8-6. A6 Path Assembly Remove and Replace | 8-25 |
| 8-7. A5 Path Assembly Remove and Replace | 8-27 |
| 8-8. A4 Path Assembly Remove and Replace | 8-29 |
| 8-9. A9 Down Converter PCA Remove and Replace (STD/OPT 002) | 8-30 |
| 8-10. A10 Up Converter PCA Remove and Replace (STD/OPT 002) | 8-31 |
| 8-11. A11 Down Converter PCA Remove and Replace (STD/OPT 002) | 8-32 |
| 8-12. A11 Down Converter PCA Remove and Replace (OPT 001/003 ONLY) | 8-33 |
| 8-13. A12 Up Converter PCA Remove and Replace (STD/OPT 002) | 8-34 |
| 8-14. A12 Up Converter PCA Remove and Replace (OPT 001/003 ONLY) | 8-35 |
| 8-15. A13 Clock/Divider PCA Remove and Replace . . | 8-37 |
| 8-16. A14 Power Supply Assembly Remove and Replace | 8-38 |

Tables

| | |
|---|------|
| 3-1. Parameter Types | 3-48 |
| 3-2. Common Commands | 3-80 |
| 3-3. Word Commands for Main Menu | 3-83 |
| 3-4. Word Commands for Simulation Test | 3-84 |
| 3-4. Word Commands for Simulation Test - Continued | 3-85 |
| 3-4. Word Commands for Simulation Test - Continued | 3-86 |
| 3-5. Word Commands for Travel Test | 3-87 |
| 3-6. Single-Key Commands | 3-87 |
| 3-7. Word Command Error and Warning Messages . . | 3-88 |
| 3-7. Word Command Error and Warning Messages - Continued | 3-89 |
| 3-7. Word Command Error and Warning Messages - Continued | 3-90 |
| 3-7. Word Command Error and Warning Messages - Continued | 3-91 |
| 3-7. Word Command Error and Warning Messages - Continued | 3-92 |
| 3-7. Word Command Error and Warning Messages - Continued | 3-93 |
| 3-7. Word Command Error and Warning Messages - Continued | 3-94 |
| 3-7. Word Command Error and Warning Messages - Continued | 3-95 |
| 6-1. Reference Designations | 6-2 |
| 6-2. Abbreviations | 6-2 |
| 6-3. Multipliers | 6-3 |
| 6-4. Replaceable Electrical Parts | 6-4 |
| 6-4. Replaceable Electrical Parts | 6-5 |
| 6-4. Replaceable Electrical Parts | 6-6 |
| 6-4. Replaceable Electrical Parts | 6-7 |
| 8-1. Troubleshooting Guide | 8-8 |
| A-1. Specifications | A-1 |
| A-1. Specifications - Continued | A-2 |
| A-2. Supplemental Characteristics | A-2 |
| A-2. Supplemental Characteristics - Continued | A-3 |
| A-3. Recommended Test Equipment | A-4 |

General Information

1-1. Introduction

This Operating and Service Manual contains information required to install, operate, test, adjust, and service the Hewlett-Packard Model 11759C RF Channel Simulator. Throughout this manual, the HP 11759C will be referred to as the Simulator. Figure 1-1 shows the RF Channel Simulator with its accessories.

The RF Channel Simulator Operating and Service manual has eight chapters and seven appendices consisting of:

- Chapter 1 General Information
- Chapter 2 Installation
- Chapter 3 Operation
- Chapter 4 Performance Tests
- Chapter 5 Adjustments
- Chapter 6 Replaceable Parts
- Chapter 7 Manual Changes
- Chapter 8 Service
- Appendix A Specifications and Test Equipment
- Appendix B Programming Examples
- Appendix C Standard Profiles
- Appendix D Dynamic ASCII Data File
- Appendix E Translation Utility Data File
- Appendix F Hardware Configuration File
- Appendix G Error Message Listings
- Index

Additional copies of the Operating and Service manual can be ordered separately through your nearest Hewlett-Packard office. The part number is listed on the title page of this manual.

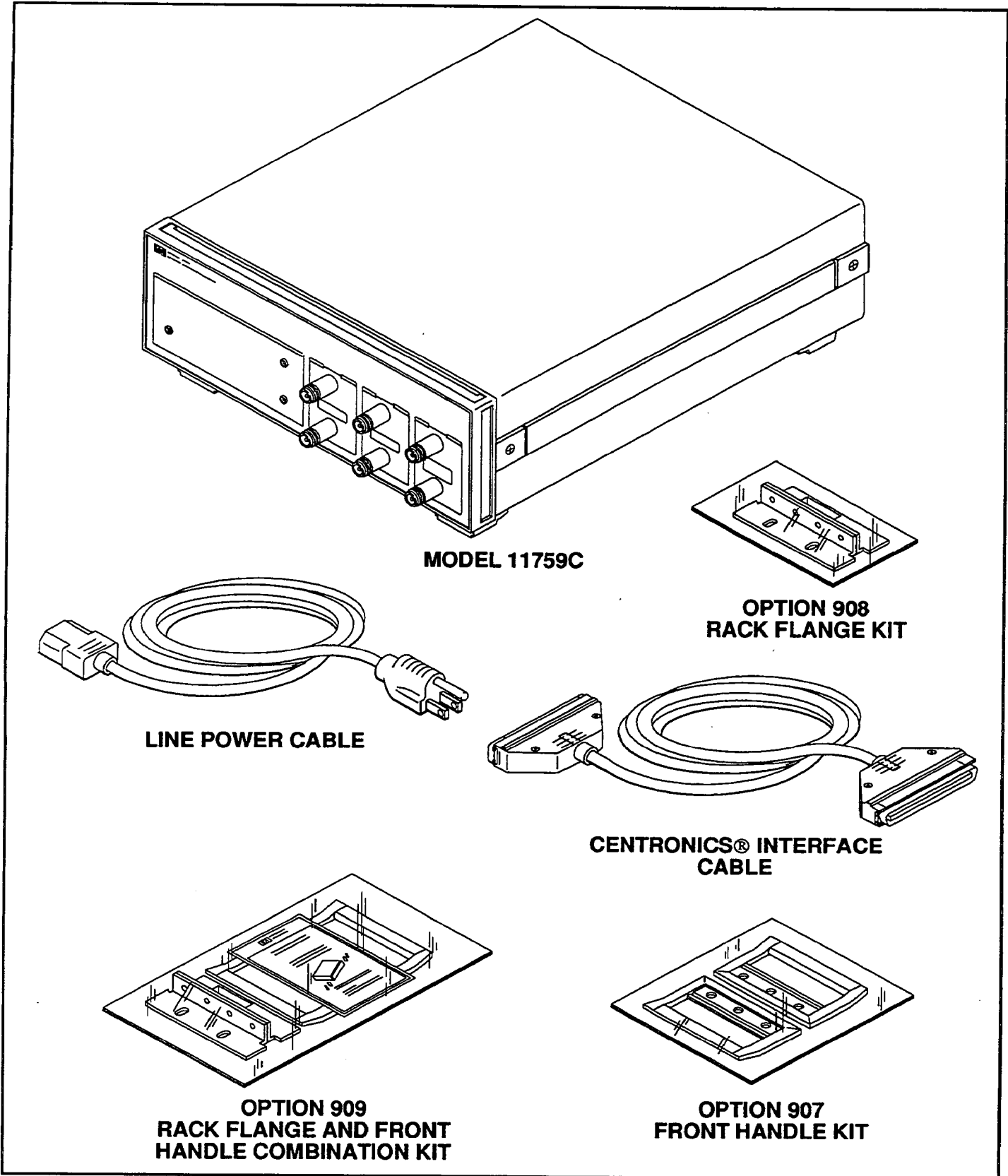

Figure 1-1. HP Model 11759C RF Channel Simulator Accessories and Mechanical Options

1-2. Specifications

Instrument specifications for the Simulator are listed in Appendix A, Table A-1. These specifications are the performance standards or limits against which the instrument may be tested. Supplemental characteristics are listed in Table A-2. Supplemental characteristics are not warranted specifications, but are typical characteristics included as additional information for the user.

1-3. Description

The RF Channel Simulator is designed to simulate the fast and slow fading, time dispersion and Doppler shifts seen in the mobile radio environment. The Simulator is specifically designed to test digital cellular radios with occupied channel bandwidths up to 6 MHz under multipath conditions. As an example, this includes:

- North American Dual-Mode Cellular System (NADC)
- Japanese Digital Cellular System (JDC)
- Global System for Mobiles (GSM)
- DCS 1800 Public Land Mobile Network

The Simulator provides either two separate RF channels each with three paths (standard and Option 002), or a single channel with six independent paths (Options 001 and 003). Each path has independent Rayleigh fading, delay, attenuation, and Doppler shift capabilities. Standard and Option 002 configurations allow co-channel, adjacent channel, and diversity tests to be performed at radio frequencies using a single instrument. Option 001 and 003 configurations allow conventional use in single channel 6-path tests, or co-channel/adjacent channel tests when two Simulator's are used in a 12-path configuration.

Operation is facilitated by using a Vectra PC and the channel simulation software supplied. The following functions are easily performed by responding to user menus displayed on the PC.

- **Channel Simulation Test** — simulates the fast fading response of a channel using a Doppler spread Rayleigh signal with combinations of time delay, Doppler shift, and attenuation.
- **Travel Test** — simulates the log-normal faded response of a channel with multiple paths and a moving receiver (or a stationary receiver and one moving reflector).

The Channel Simulator software also supports remote control of the Vectra PC. Using this feature, the Vectra PC which runs the simulation software can be remotely controlled via an HP 82335A HP-IB card, or the serial I/O port, using a remote terminal or computer (such as the Series 300 computer running HP BASIC/WORKSTATION). Most simulation software menus can be accessed and controlled from the remote device.

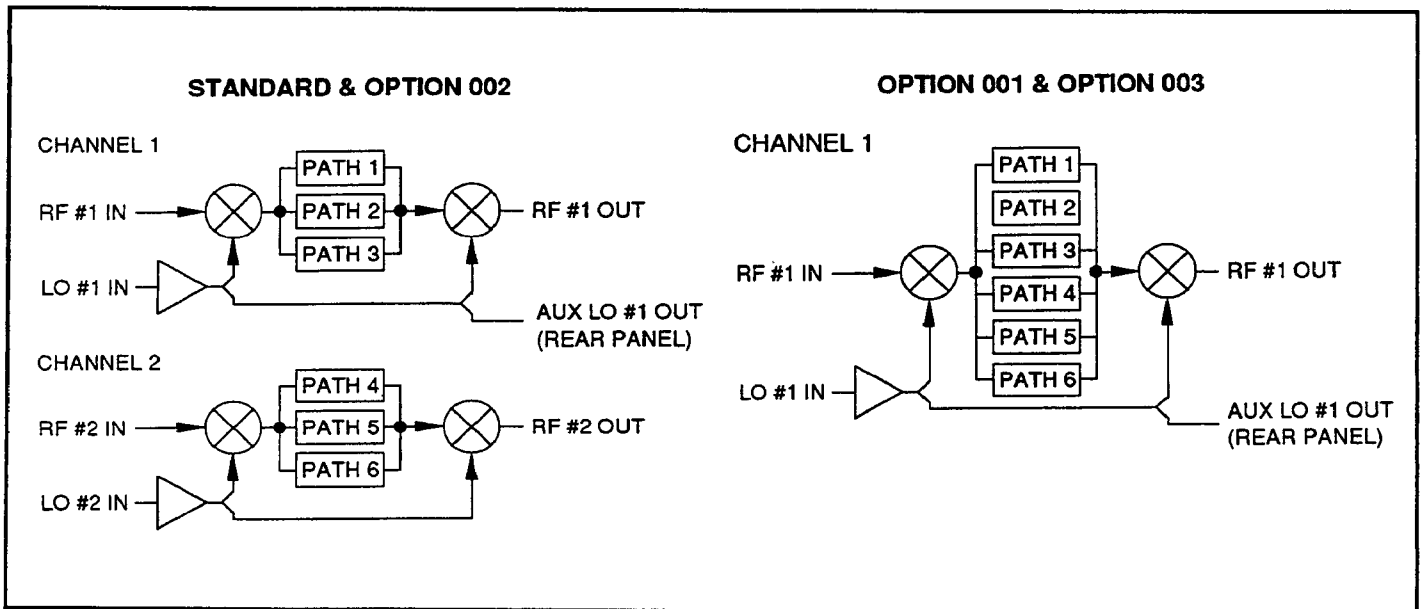

Figure 1-2. HP Model 11759C Simplified Block Diagram

1-4. Minimum System Configuration

The HP 11759C RF Channel Simulator consists of the applications software and the RF processing hardware. To complete the RF multipath simulation system, two other user supplied components are necessary. These instruments may be ordered, or information about them may be obtained by contacting your nearest Hewlett-Packard office. **Controller.** The HP Model 486/33U Model 120 PC with HP 11759C controller software acts as the front panel/controller that provides the Simulator with the necessary control functions.

The HP Model 486/33U Model 120 PC and the CompuDyne 486 DX33 Laptop computer are the two controllers that have been extensively tested as HP 11759C controllers. There may be other controllers that are suitable, but HP cannot guarantee which particular controllers these may be. The minimum requirements listed are meant to provide a generic guideline for other controllers. It is up to the customer to fully confirm that any controllers other than the two listed will perform as described in this manual.

- 486 DX Microprocessor at ≥ 33 MHz
- 3.2 Mbyte RAM disk (configured as extended or expanded memory)
- Hard drive with a minimum of 32 Mbyte free space
- 3 1/2" (1.44 Mbyte) or 5 1/4" (1.2 Mbyte) Floppy Disk Drive
- Parallel Printer Interface
- Centronics® Interface Cable (HP 24542D)

- EGA or VGA Graphics Adapter
- MS-DOS 5.0 or higher
- HP-IB Interconnect Cable (HP 82333B) – optional
- HP-IB Card (for HP-IB Operation) (HP 82335A) – optional
- Parallel Interface Card (for the second HP 11759C Simulator as part of 12-path operation) (HP 24540B)

Local Oscillator. The HP Model 8657B Synthesized Signal Generator provides the Simulator with a Local Oscillator signal input used to determine the IF operating frequency, and to supply the 0 to +20 dBm 10 MHz Time Base Reference input. Connection is provided using a type N cable (LO) and a BNC cable (Timebase).

1-5. Safety Considerations

The Simulator and all related documentation should be reviewed for familiarization with safety markings and instructions before operation. Refer to the Safety Considerations page found at the beginning of this manual for a summary of the safety information. Safety information for installation, operation, performance testing, adjustment, or service is found in appropriate places throughout this manual.

1-6. Instruments Covered By This Manual

Attached to the rear panel of the instrument is a serial number plate. The serial number is in the form: 0000A00000. The first four digits and the letter are the serial number prefix. The last five digits are the suffix. The prefix is the same for identical instruments; it changes only when a configuration change is made to the instrument. The suffix however, is assigned sequentially to instruments having the serial number prefixes listed under SERIAL NUMBERS on the title page.

1-7. Manual Changes Supplement

In addition to updated information, Manual Changes supplements may also provide corrections to errors in manuals.

Manual Changes supplements may be obtained by contacting your nearest Hewlett-Packard Sales office. To receive the correct documentation for your product, you will need to provide the instrument's name, model number, and serial number.

For information concerning a serial number prefix not listed on the title page, or in the Manual Changes supplement, contact your nearest Hewlett-Packard Sales office.

1-8. Options

The following options may have been ordered and received with the Simulator. If they were not ordered with the original shipment and are now desired, they can be ordered from the nearest Hewlett-Packard office using the part numbers included in each of the following paragraphs.

Single Channel with Front Panel Connectors (Option 001). One channel (Channel #1) with six independent paths is provided with front panel connectors.

Two Channel with Rear Panel Connectors (Option 002). All front panel connectors are located on the rear panel.

Single Channel with Rear Panel Connectors (Option 003). One channel (Channel #1) with six independent paths is provided with rear panel connectors. **Front Handle Kit (Option 907).** Ease of handling is increased with the front panel handles. The Front Handle Kit HP part number is 5062-3989. **Rack Flange Kit (Option 908).** The Simulator can be solidly mounted to the instrument rack using the flange kit. The Rack Flange Kit HP part number is 5062-3977.

Rack Flange and Front Handle Combination Kit (Option 909). This is a unique part which combines both functions. It is not simply a rack flange kit and front handle kit packaged together. The HP part number is 5062-3983.

Additional Operating and Service Manual (Option 910). An additional operating and service manual is shipped with each unit.

1-9. Accessories Supplied

The following accessories are supplied with the Simulator:

Channel Simulation Software. The Simulator is operated by a suitable (refer to paragraph 1-4) Vectra PC (or compatible computer) using a series of application programs supplied with the instrument. See Turn-on procedures in Chapter 3 of this manual for more information.

Line Power Cable. The line power cable is supplied in several configurations, depending on the destination of the original shipment. Refer to Power Cables in Chapter 2 of this manual for more information. **Centronics Interface Cable.** This cable provides a means of transfer for all operational control signals between the Simulator and PC. It is connected to a 36 pin parallel interface port on the back of the computer used to run the Simulation software. See Turn-on and Operation procedures in Chapters 2 and 3 for more information.

1-10. Recommended Test Equipment

Table A-3 in Appendix A lists the test equipment recommended for use in testing, adjusting, and servicing the Simulator. The Critical Specification column describes the essential requirement for each piece of test equipment. Other equipment can be substituted if it meets or exceeds these critical specifications.

Installation/Verification

2-1. Introduction

This section provides the information needed to install the Simulator, and verify it is properly functioning. Included is information pertinent to initial inspection, power requirements, line voltage selection, power cables, interconnection, environment, set-up and turn-on, functional check, storage and shipment.

Warning



To avoid hazardous electrical shock, do not perform electrical tests when there are signs of shipping damage to any portion of the outer enclosure (covers, panels, connectors).

2-2. Initial Inspection

Inspect the shipping container for damage. If the shipping container or cushioning material is damaged, it should be kept until the contents of the shipment have been checked for completeness and the instrument has been checked mechanically and electrically. The contents of the shipment should be as shown, in Figure 1-1. Also sent with the shipment is the instrument Operating and Service Manual. Procedures for checking electrical verification are given in Section 2-6. If the contents are incomplete, or if there is mechanical damage or defect, or if the instrument does not pass the electrical verification tests, notify the nearest Hewlett-Packard office. Keep the shipping materials for the carriers inspection.

2-3. Preparation for Use

Power Requirement

The Simulator requires a power source of from 90 to 132 Vac or 190 to 264 Vac single phase. Line frequency is 48–66 Hz. Power consumption is 325 VA maximum.

Warning



This is a Safety Class I product (that is, provided with a protective earth terminal). An uninterruptible safety earth ground must be provided from the main power source to the product input wiring terminal, power cable or supplied power cable set. Whenever it is likely that the protection has been impaired, the product must be made inoperative and be secured against any unintended operation.

Warning



If this instrument is to be energized via an external autotransformer, make sure the auto transformer's common terminal is connected to the neutral (that is, the grounded side of the mains supply).

Line Voltage and Fuse Selection

Verify that the line voltage selection and the fuse are matched to the power source. Refer to Figure 2-1, Line Voltage and Fuse Selection.

Fuses (two are required) may be ordered under HP part number 2110-0924, 3.5A (250V) for 90 to 132 Vac, and 2110-0633 2.5A (250V slo-blo) for 190 to 264 Vac operation.

Caution



BEFORE PLUGGING THIS INSTRUMENT into the mains (line) voltage, be sure the correct voltage and fuse have been selected.

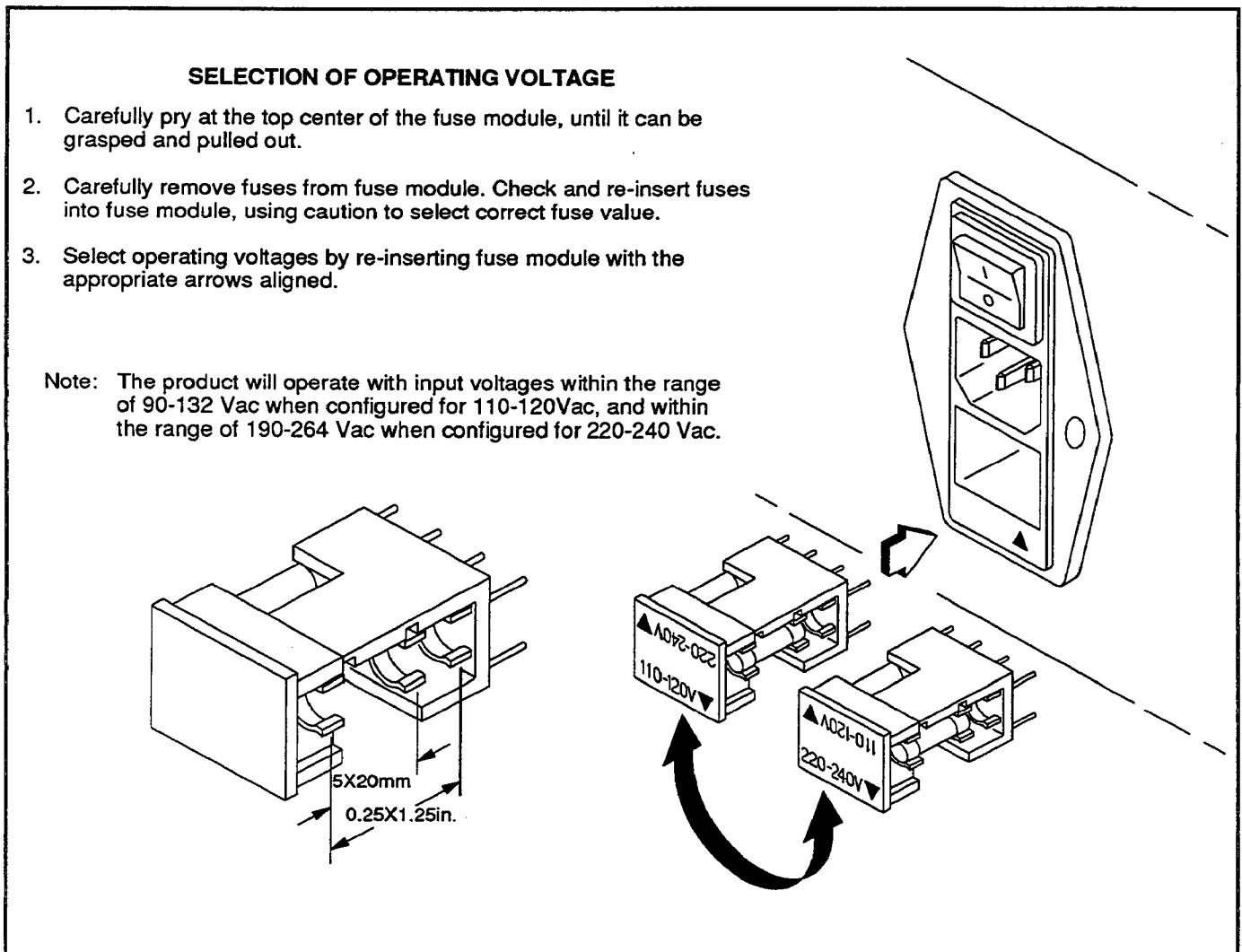

Figure 2-1. Line Voltage and Fuse Selection

Power Cables

This instrument is equipped with a three-wire power cable. When connected to an appropriate ac power receptacle, this cable grounds the instrument cabinet. The power cable plugs shipped with each instrument depend on the country of destination. Refer to Figure 2-2 for the part numbers of power cables available.

Warning



BEFORE CONNECTING THIS INSTRUMENT, the protective earth terminal of this instrument must be connected to the protective conductor of the lines (mains) power cable. The line plug shall only be inserted in a socket outlet provided with a protective earth contact. The protective action must not be negated by the use of an extension cord (power cable) without a protective conductor (grounding). Grounding one conductor of a two conductor outlet is not sufficient protection.

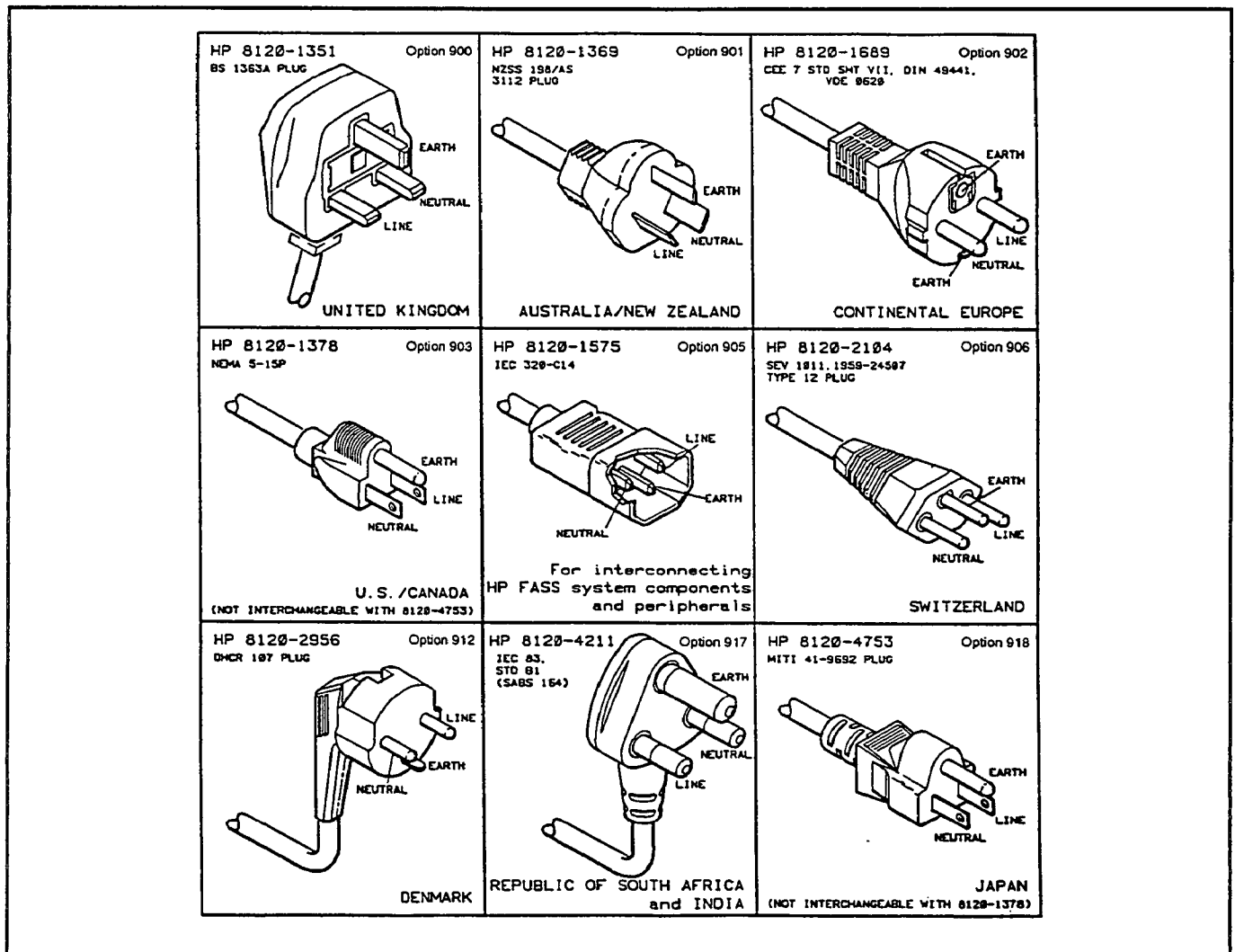

Figure 2-2. Power Cable and Mains Plug Part Numbers

Mating Connectors

Coaxial mating connectors used with the Simulator are eight 50Ω. Type N female connectors and one 50Ω BNC female connector. A 36 pin Parallel Printer interface connector is located on the Rear Panel.

Interconnections

Interconnection to the 36 pin series D Parallel Printer Interface Connector is accomplished using a standard six foot Centronics® interface cable (HP P/N 24542D). Cable length must not exceed six feet. The parallel interface logic levels are TTL.

Operating Environment

The Operating Environment for the Simulator should be maintained within the following limitations:

- Specified Temperature Range +15 to +35°C
- Operating Temperature Range 0 to +55°C
- Humidity 0 to 95% at 0 to +40°C
- Altitude <4,600 Meters (15,000 feet)

2-4. Set-Up and Turn-On Procedures

These procedures are designed to assist the user in performing the initial Simulation System equipment set-up, and to install the system software. Perform the following steps to set-up and turn-on the Simulator.

Note



The standard instrument is shown in the following figure. Connection to instruments with options is the same, making connections on the rear panel in lieu of the front panel for the rear panel options. Connection to up to two Simulators is possible, however each requires a separate parallel interface port.

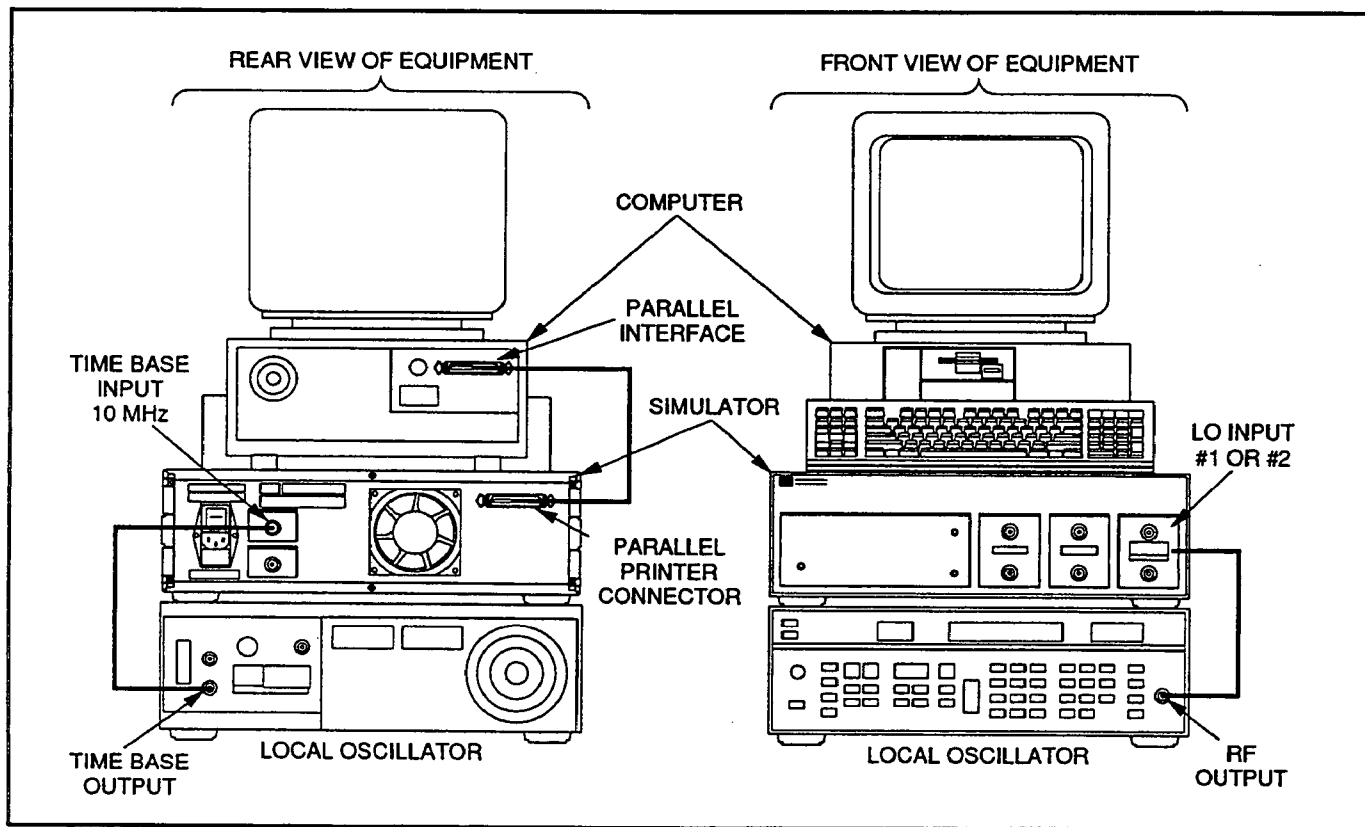

Figure 2-3. Set-up and Turn-On Procedures

1. Connect the Simulation System as shown in Figure 2-3.
 - On the Simulator rear panel, verify that the line voltage selector is set for the line (Mains) voltage source available in your area. Check that the fuse rating is appropriate for the line voltage used. Refer to Figure 2-1 for more information.
 - Verify that the correct line voltage selection, fuses, and power cables have been selected for all instruments. Instructions are given in the Installation Section of each manual.

- Verify interconnecting cables are connected to the correct instrument.
2. Verify the individual instrument power switches are set to the OFF or STBY positions. Connect power cables to the available voltage source.
 3. Set the power switches of the individual instruments to ON. Verify each instrument performs the correct turn-on procedure using the individual instrument manuals.

Note

If an instrument turn-on malfunction is detected, correct using the individual instrument manual before proceeding.

4. After individual instruments have all been turned on, allow 10 minutes for warm-up of the HP 11759C, or the minimum warm-up of the other instruments, whichever is longer.
5. Set the Computer power switch to ON and allow the computer to boot-up.

Note

The Channel Simulator software and the data files will occupy approximately 3.1 MBytes on the hard disc (1.4M for application and data files). The fading datafiles built at the end of the install process require approximate 30M of free disk space.

The Channel Simulator software should not be run under Windows, (Windows is a registered TM of Microsoft). The Rayleigh data rate is slowed considerably by the additional Windows overhead. In addition, the Channel Simulator has not been tested on the DOS 5.0 Task Switcher.

If installing the Channel Simulation software for the first time, proceed as follows:

- Make a copy of the Channel Simulation master disk(s). Use the copy for installation and store the master disk(s) in a safe location.
- Insert the copy of the HP 11759C RF Channel Simulator Software "PROGRAM DISC" into the floppy drive.
- Type "X:INSTALL" where X is the floppy drive that the program disc is installed into (e.g., "A:INSTALL"), then follow the instructions displayed on the screen. Note that the remainder of the installation procedure assumes that the files have been installed in the factory default C:\CHANSIM directory.
- To exit the installation process prior to completion, press the ESCAPE key.
- See the sample "CONFIG.SYS" file on the Program disk for an example of how to manually configure a RAM disk.

After installation of all the files on the installation disk(s), the screen displays: "Type iqmake -d and press [ENTER] to build the Rayleigh .IQ fading datafiles". Perform as instructed. This process will build the default fading datafiles (also referred to as .IQ files or Rayleigh files). This typically takes ≈4.5 hours to perform and requires approximately 32M of free disk space. For more information on building selective fading datafiles, see Chapter 3.

To run the channel simulation software, type "CD C:\CHANSIM" to get to the CHANSIM directory then type "CHANSIM". Verify the Computer display is as follows:

DATA SHOWN IN SCREEN FOR EXAMPLE ONLY

```

HP11 759C/D RF Channel Simulator                               MAIN MENU
Copyright (c) Hewlett-Packard Co. 1993

----- MENU -----

S: Simulation Test
D: Dynamic Test
T: Travel Test
C: Configuration
H: Help (first-time installation tips)
Q: Quit

Note: The system configuration needs to be specified. Use the
      configuration menu to do this.

Enter selection . . .

```

- If screen display is incorrect, repeat turn-on/boot-up procedures.
- If screen display is still incorrect, troubleshoot computer and instruments using the individual manuals.

Note



If the screen is shown after initial installation, a message indicating that the System Configuration must be entered is displayed. Select "C" and follow the displayed instructions to enter your equipment configuration.

6. The Simulator System is now available to execute all menu selections. See Chapter 3, Operation, for instructions on using the Simulator System.
7. See Section 3-9 for remote setup and operation.

Software Removal

To remove the HP 11759C software and RAM disk declarations from your Vectra PC, follow these steps:

1. The RAM drive was manually configured in the previous INSTALL process. If the RAM drive is only being used for the 11759 software, remove the RAM drive declarations from the "config.sys" file. Do not remove the RAM drive declaration if it is being used by other applications.
2. Remove all files from the Program Directory, which is specified in the Preference menu. (e.g., DEL C:\CHANSIM*.*). This will delete all files in the Program Directory, including any that have been manually added. When finished, change to the "root" directory (CD\).
3. Remove the Program Directory (e.g., RMDIR C:\CHANSIM).

2-5. Installing Remote Control

These procedures are designed to assist the user in connecting and configuring the Simulation System for remote operation (either HP-IB or serial) using a terminal or computer to operate the Vectra PC from another location. Perform the following steps to connect and configure for remote operation.

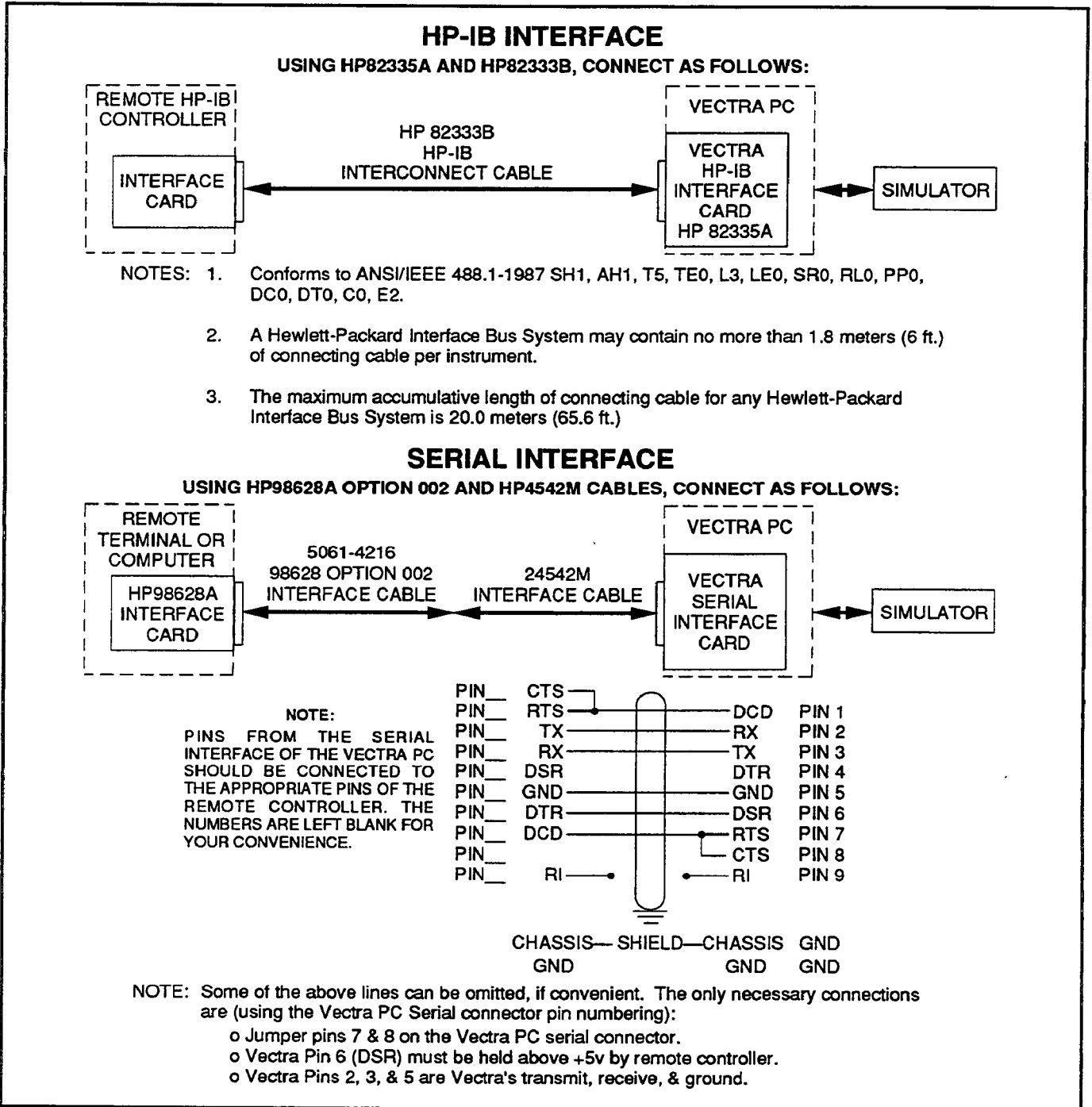

Figure 2-4. Installing Remote Terminal/Computer Procedures

1. Verify that the Set-up and Turn-on procedures (paragraph 2-4) have been performed. Quit the simulation software by selecting "Q".
2. Connect the remote terminal or computer serial interface, or remote HP-IB controller to the Vectra PC as shown in Figure 2-4.
HP-IB Interface – connect remote HP-IB controller using a two meters (maximum length) HP-IB cable (HP 10833B).
Serial Interface – use the terminal or computer manuals for corresponding pin numbers on the remote device's serial interface.

Note



An example wiring diagram is available in the file REMOTE.DOC which was installed with the HP 11759C software in the Program Directory. CD to CHANSIM directory, and type "MORE <REMOTE:DOC" and press <ENTER> at the DOS prompt to see this document.

3. Configure the HP-IB or serial interface card as follows (refer to the terminal or computer and interface card manuals for selection information):
HP-IB Interface – must be set to the non-system controller mode to execute the Simulation software. On the HP 82335 card, selection is automatically set to non-system when the Simulator software is executed and returns to the previous system controller mode when the simulation software is terminated. The mode is changed only if HCHANSIM or HGHOST is executed.

Note



The HP-IB card uses interrupts because it is being used in a non system controller mode. Follow the directions for "Installing the HP-IB Interface" to verify that interrupts are enabled, then check your computer manual for any additional set-ups to enable HP-IB interrupts. Verify that no other card in the computer is using the same interrupt number.

If for some reason the system controller mode is not restored correctly when the Simulator software is terminated, either cycle the PC power to off then on, or use SYSCTL.EXE (installed in the CHANSIM directory) to change the system controller mode.

Normally, slot number and bus address are as follows:

| | |
|---------------------------|----|
| HP-IB Slot Number | 7 |
| HP-IB Bus Interface | 14 |

Serial Interface – is configured as follows:

Note



It is highly recommended that a serial data rate of 300 baud (or lower) be used to avoid data loss when using serial remote control.

```

Baud Rate .....300
Parity ..... None
Databits .....7
Stopbits ..... 1
Handshake ..... OFF (non-modem-connection)
Data Mode .....ASYNC
    
```

4. Set the remote terminal or computer power switch to ON and allow the device to boot-up. Execute the terminal emulation or communications application program, and set the controller program parameters as follows (refer to the terminal, computer, and software application program manuals for more information):

HP-IB Interface - no additional configuration is required.

Serial Interface - is configured as follows: **Datacom Configuration**. (e.g. HP 98791B Terminal Emulator Program)

```

Baud Rate .....300
Parity ..... None
Parity Check .....No
Databits .....7
Stopbits ..... 1
Handshake ..... Xon Xoff
Modem Handshake ..... OFF
Gap Time .....0
    
```

Terminal Configuration

```

Local Echo ..... NO
Mode ..... Direct
Port ..... COMM 1
    
```

5. Set the Vectra PC power switch to ON and allow the computer to boot-up.
6. **HP-IB Interface** – If slot number and bus address are changed from the defaults (7 and 14 respectively), the Simulation software must be reconfigured by selecting "C" from the Main Menu.

Serial Interface – If the datacom parameters are changed from the above, then reconfigure the installed simulation software remote operation parameters by editing "RCHANSIM.BAT" and "RGHOST.BAT" in the CHANSIM directory. These parameters must match the remote terminal or computer parameters previously set. Default parameters are as follows:

Baud Rate300
 Parity None
 Databits 7
 Stopbits 1

Set the remote terminal or computer so the DSR line on the Vectra PC is pulled high (reset). Refer to the terminal or computer manual for selection information.

Note



Two programming examples are provided in Appendix B that automatically resets the simulator and demonstrates both the HP-IB and the serial remote control operation (steps 7 thru 9).

7. To run the remote channel simulation software:

HP-IB Interface – type "HCHANSIM" or "HGHOST" from the CHANSIM directory. Verify the Computer display is as follows:

Serial Interface – type "RCHANSIM" or "RGHOST" from the CHANSIM directory. Verify the Computer display is as follows:

DATA SHOWN IN SCREEN FOR EXAMPLE ONLY

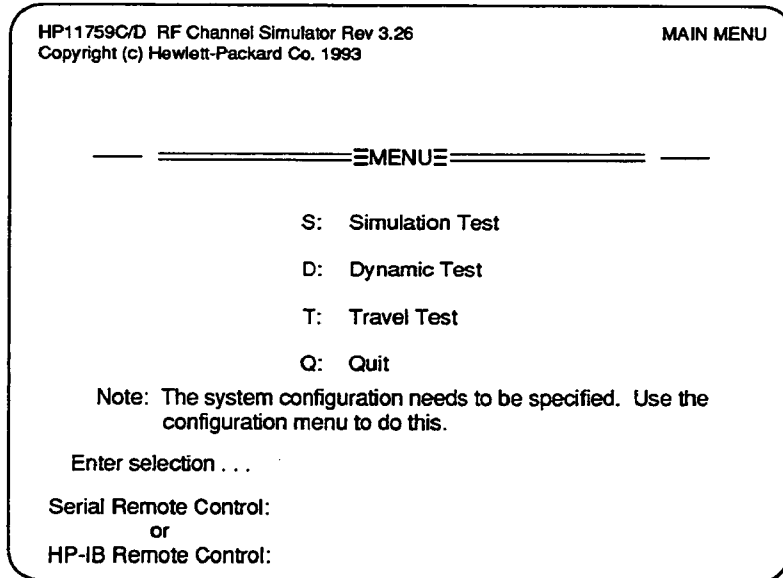

Note



If the screen is shown after initial installation, a message indicating that the System Configuration must be entered is displayed. Select "C" and follow the displayed instructions to enter your equipment configuration.

8. If Port 1 is not used as the "11759 Interface Port Number", then the Configuration Menu should be changed accordingly.

Note

Port 2 or port 3 may not work on some PC compatible computers. The recommended way to connect a parallel printer and the HP 11759C is to connect the printer to LPT2, and leave the HP 11759C Port number at 1.

9. From the remote terminal or computer:

Serial Interface – send "IDENTIFY?" with a terminating CR (no linefeed). Verify "IDENTIFY?" is echoed at the bottom of the PC screen, followed by the revision of the simulator software. The date should also appear at the remote terminal or computer.

HP-IB Interface – send "*IDN?" with a terminating LF (decimal 10). Verify "HEWLETT-PACKARD,<instrument-number>, 0, <revision-number>" is echoed at the bottom of the PC screen and at the remote HP-IB controller.

- If correct, the Simulator System is now available to remotely execute all menu selections. See Chapter 3, Operation and Remote Operation, for instructions on using the Simulator System.
- If incorrect, proceed as follows:
 1. Verify the remote terminal or computer and Vectra PC are connected as described earlier in this paragraph.
 2. **HP-IB Interface** - Verify that the address and slot numbers are correctly set.

Serial Interface - Verify the remote terminal, computer, or controller, Vectra PC computer, interface cards, communication program, and simulation software program are all set to the same baud rate, parity, databits, and stop bits.

Serial Interface - If the Vectra PC keeps displaying 'timeout' messages, then the remote controller has not raised the Vectra PC's DSR line. Raise this line to stop the timeout messages, or enter a Ctl-C from the Vectra PC keyboard to stop the timeout messages and exit the channel simulation software.

Serial Interface - It may be useful to connect an external terminal's receive line to the transmit line of the remote controller to make sure it's sending in the right data format, baud rate, etc. Likewise, the terminal transmit line could be connected to the Vectra PC's serial line to drive the Channel Simulator directly.

2-6. System Verification Check

The System Verification Check procedure is designed to verify the proper operation of the Simulator's main functions. This procedure, requires a spectrum analyzer and two signal generators. It gives reasonable assurance that all paths are performing basic functions.

Description

This check has been designed to be performed with a minimum of test equipment and in as short a time as possible, and is extremely valuable in identifying malfunctions.

If a malfunction is suspected, the entire check should be performed in the order given. Make a note of all the steps that failed. Refer to the Service Manual for the appropriate troubleshooting procedures to follow if the Simulator System is to be repaired at the user's facility.

If the Simulator System is to be returned to Hewlett-Packard for repair, fill out a blue repair tag (found at the end of this manual). Include on the back of the tag a list of all checks that failed and attach the tag to the instrument. This will give the repair technician a good description of the malfunction and help assure the best possible service and the shortest repair time.

Equipment

| | |
|---------------------------------|-----------------------------|
| Computer | HP Vectra 486/33U (minimum) |
| Spectrum Analyzer | HP 8566B |
| Signal Generator (2 each) | HP 8657B |

Procedure

1. Connect the test equipment as shown in figure 2-5.

Note



The standard instrument is shown in figure 2-5. Connection to instruments with options is the same, making connections on the rear panel in lieu of the front panel when necessary.

2. Set the signal source controls as follows:

| | |
|--------------------|---------|
| FREQUENCY | 900 MHz |
| OUTPUT LEVEL | -10 dBm |

3. Set the local oscillator controls as follows:

| | |
|--------------------|---------|
| FREQUENCY | 894 MHz |
| OUTPUT LEVEL | +10 dBm |

4. Set the spectrum analyzer controls as follows:

| | |
|------------------------|---------|
| CENTER FREQUENCY | 900 MHz |
| FREQ SPAN | 1 kHz |

Note



Select the Install Help Menu for a list of frequently asked questions about the HP 11759C installation.

5. On the computer, if the 11759C menu is displayed, exit to the DOS prompt and perform the following steps. If the DOS prompt is already displayed, perform the following steps:

- a. Type CD \CHANSIM on the computer keyboard and press **Enter**.
 - b. Type CHANSIM on the computer keyboard and press **Enter**.
 - c. At the 11759C main menu, type **S** on the computer keyboard.
6. Set the HP 11759C PATH #1 SPECTRUM to Doppler.
 7. Set the HP 11759C PATH #1 DELAY to 0 μ sec.

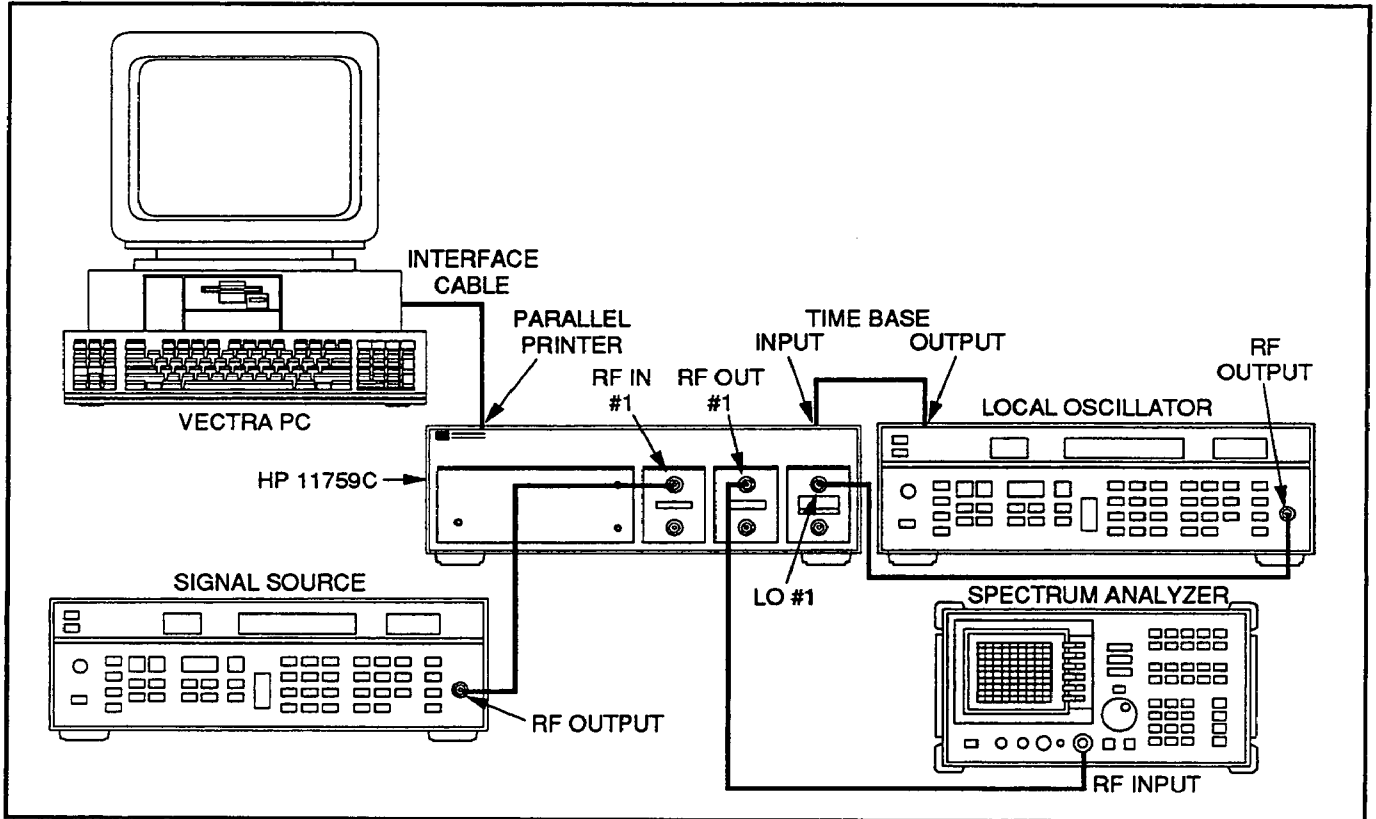

Figure 2-5. System Verification Check Setup

8. Verify the signal displayed on the spectrum analyzer is approximately -30 dBm at 900 MHz. Record the level reading for later use.

Note



If the signal is not displayed on the spectrum analyzer, increase **FREQ SPAN** to locate the signal, readjust the **CENTER FREQ** to the signal peak, then reduce the **FREQ SPAN** to 1 kHz.

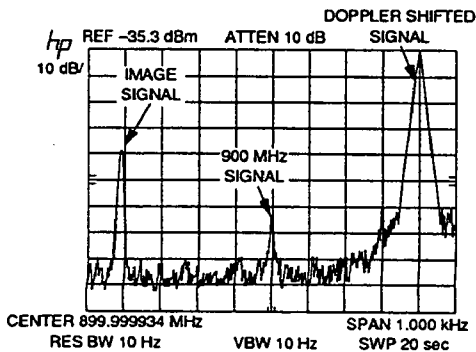

9. Set the HP 11759C PATH #1 DOPPLER to 425 Hz.
10. Verify the signal displayed on the spectrum analyzer is similar to that shown. (The image signal shown is worst case. The image and center signals are the result of imbalances in the I/Q modulation. If they exist, they should meet all level specifications).

Using the DELTA MARKER function, verify the difference between the Doppler shifted signal and if visible, the 900 MHz signal is approximately 425 Hz at >30 dB, and the difference between the Doppler shifted signal and the image signal (if it can be seen) is approximately 850 Hz at >30 dB.

11. Set HP 11759C PATH #1 DOPPLER to 0 Hz, and ATTEN to 20 dB.
12. Verify the signal displayed on the analyzer decreases by approximately 20 dB.
13. Reset the HP 11759C by pressing "CTRL-BACKSPACE" keys.
14. Repeat steps 6 through 13 for the PATH #2 and PATH #3.
15. Set the signal source controls as follows:

FREQUENCY 900 MHz
 OUTPUT LEVEL -10 dBm
 MODULATION FM
 MOD RATE 1 kHz
 MOD DEVIATION 50 kHz

16. Set the spectrum analyzer controls as follows:

CENTER FREQUENCY 900 MHz
 FREQ SPAN 200 kHz

17. Set the HP 11759C PATH #1 SPECTRUM to Doppler.
18. Set the HP 11759C PATH #1 DELAY to 0 μ sec.
19. Verify the signal displayed on the spectrum analyzer is 900 MHz modulated at 50 kHz.
20. Set the HP 11759C PATH #2 SPECTRUM to Doppler.
21. Set the HP 11759C PATH #2 DELAY to 0 μ sec.
22. Verify the FM signal level displayed on the spectrum analyzer increases.
23. Set the HP 11759C PATH #2 DELAY to 25 μ sec.

24. Verify the signal displayed on the spectrum analyzer now has notches in the passband, and as shown, the frequency difference between the notches is approximately:

$$\frac{1}{\text{delay}}, \text{ which is } 40 \text{ kHz.}$$

If this signal is correct, it verifies that the 25 μ sec DELAY on the selected PATH (#2 in this case) is operational.

25. Set the HP 11759C PATH #3 SPECTRUM to Doppler.
26. Set the HP 11759C PATH #3 DELAY to 25 μ sec.
27. Repeat step 24 (tests PATH #3 DELAY).
28. Set the HP 11759C PATH #3 DELAY to 0 μ sec, and the PATH #1 DELAY to 25 μ sec.

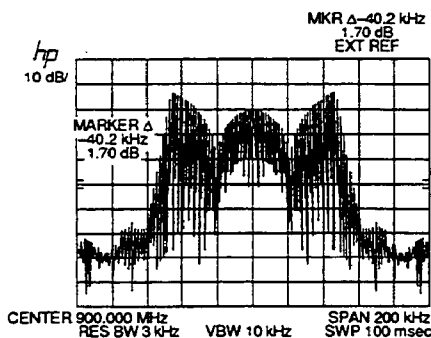

29. Repeat step 24 (tests PATH #1 DELAY).
30. Reset the HP 11759C by pressing the "CTRL-BACKSPACE" keys.
31. Set the spectrum analyzer controls as follows:
 - CENTER FREQUENCY900 MHz
 - FREQ SPAN 10 KHz
 - REF LEVEL -30 dBm
 - DBM/DIV 1 dB/Div
32. Set the HP 11759C PATH #1 SPECTRUM to Doppler.
33. Set the spectrum analyzer controls as follows:
 - PressPEAK SEARCH
 - Record the measured level
 - PressMARKER DELTA
34. Set the HP 11759C PATH #1 SPECTRUM to OFF, and the PATH #2 SPECTRUM to Doppler.
35. On the spectrum analyzer, press PEAK SEARCH and record the measured level. Verify the difference between path #1 and Path #2 recorded levels is less than 0.1 dB.
 - If the difference between paths is more than 0.1 dB, adjust Path Insertion Loss matching using procedure in Chapter 5.
36. Set the HP 11759C PATH #2 SPECTRUM to OFF, and the PATH #3 SPECTRUM to doppler.
37. On the spectrum analyzer, press PEAK SEARCH and record the measured level. Verify the difference between Path #1 and Path #3 recorded levels is less than 0.1 dB.
 - If the difference between paths is more than 0.1 dB, adjust Path Insertion Loss matching using procedure in Chapter 5.
38. Repeat steps 2 through 37 for:
 - *Standard and Option 002:* channel 2 substituting path 4 for path 1, path 5 for path 2, and path 6 for path 3.
 - *Option 001 and 003:* substituting path 4 for path 1, path 5 for path 2, and path 6 for path 3.
39. Remove power and disconnect test equipment.

Note



If the Vectra PC Parallel Printer Port wiring or the PC ROM BIOS are suspect, the PORTTEST program can be run. It may be used along with an external parallel printer, logic probe (or DVM), and a 5V pullup power supply to verify the pinouts of the PC to Simulator cable. For more information, CD to CHANSIM directory, then type "PORTTEST" and press the ENTER key.

2-7. Storage and Shipment

- Environment** The instrument should be stored in a clean, dry environment. The following environmental limitations apply to both storage and shipment:
- | | |
|-------------------|-----------------------------|
| Temperature | -55 to +75°C |
| Humidity | <95% relative |
| Altitude | 15,300 meters (50,000 feet) |
- Packaging**
- TAGGING FOR SERVICE.** If the instrument is being returned to Hewlett-Packard for service, please complete one of the blue repair tags located at the end of this manual and attach it to the instrument.
- ORIGINAL PACKAGING.** Containers and materials identical to those used in factory packaging are available through Hewlett-Packard offices. If the instrument is being returned to Hewlett-Packard for servicing, attach a tag indicating the type of service required, return address, model number, and full serial number. Also mark the container "FRAGILE" to assure careful handling. In any correspondence refer to the instrument by model number and full serial number.
- OTHER PACKAGING.** The following general instructions should be used for repackaging with commercially available materials.
- Wrap the instrument in heavy paper or anti-static plastic. (If shipping to a Hewlett-Packard office or service center, attach a tag indicating the type of service required, return address, model number, and full serial number).
 - Use a strong shipping container. A double-wall carton made of 2.4 MPa (350 psi) test material is adequate.
 - Use enough shock-absorbing material 75 to 100 mm (3 to 4 inches) thick around all sides of the instrument to provide a firm cushion and prevent movement in the container. Protect the front panel with an appropriate type of cushioning material to prevent damage during shipment.
 - Seal the shipping container securely.
 - Mark the shipping container "FRAGILE" to assure careful handling.
 - In any correspondence refer to the instrument by model number and full serial number.

Operation

3-1. Introduction

This section provides complete operating information for the Simulator. Included in this section are the description of front and rear panel connectors and indicators, operator's checks, operator's maintenance, and operating instructions.

3-2. Operating Characteristics

Simulator Performance Specifications and Supplemental Characteristics are contained in Tables A-1 and A-2.

3-3. Panel Features

The front and rear panel features are given in Figure 3-1. These include explanations of all the connectors and indicators.

3-4. Operator's Maintenance

Warning



For continued protection against fire hazard, replace the line fuse with a 250 V fuse of the same rating only. Do not use repaired fuses or short-circuited fuseholders.

Operator's maintenance consists of replacing defective fuses. The primary power fuses are located within the line module assembly. Refer to Figure 2-1 for instructions on how to change the fuse.

3-5. Operating Instructions

Warning



Before the instrument is switched on, all protective earth terminals, extension cords, autotransformers, and devices connected to the instrument should be connected to a protective earth grounded socket. Any interruption of the protective earth grounding will cause a potential shock hazard that could result in personal injury.

Caution



Before the instrument is switched on, it must be set to the voltage of the power source or damage may result.

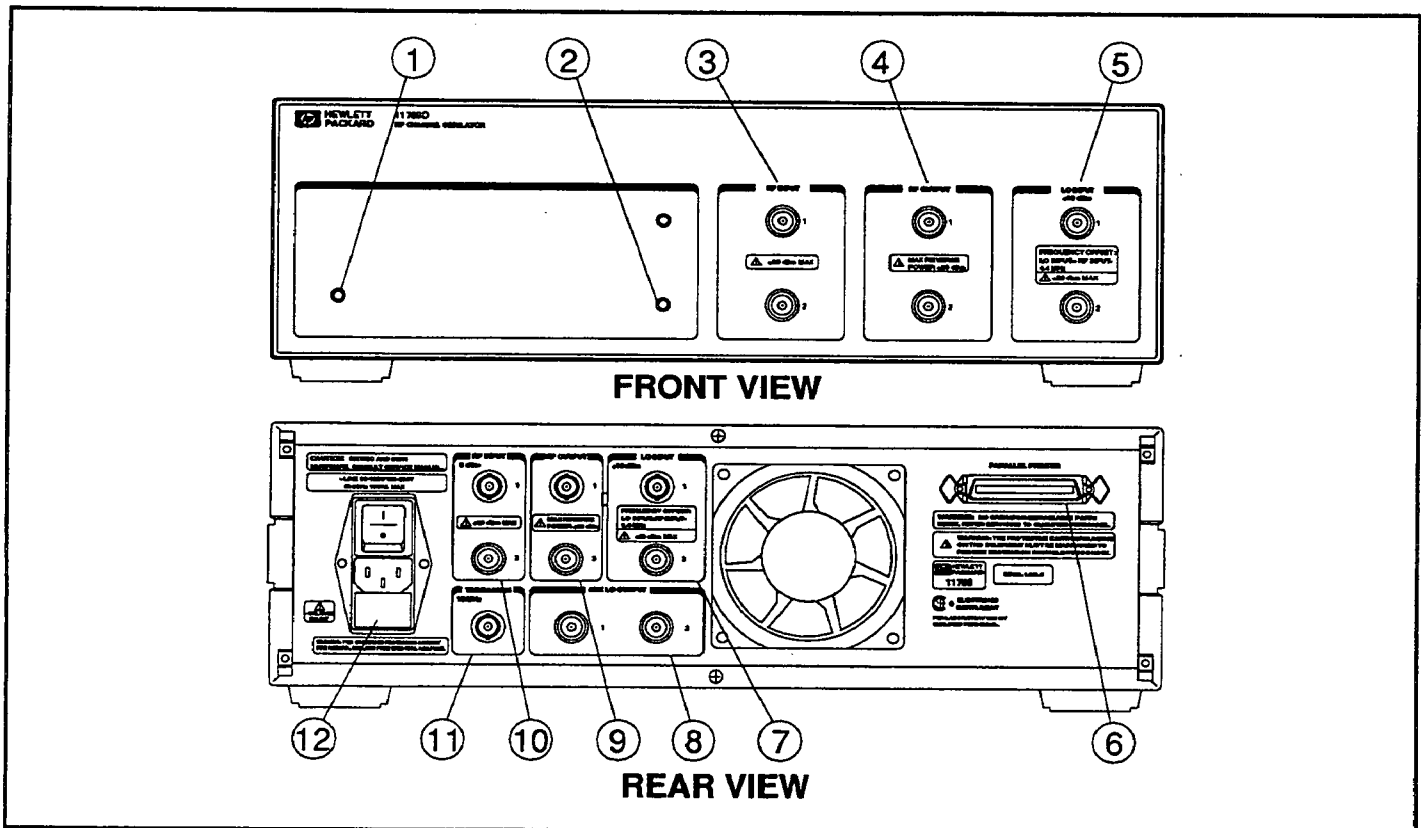

Figure 3-1. Front and Rear Panel Connections and Indications

1. LINE INDICATOR illuminates when the instrument is turned on.
2. OVERRANGE INDICATOR illuminates when the power input to the channel's RF input connector is above the optimum level.

3. FRONT PANEL RF INPUT CONNECTORS. *Not available for option 002 or 003.* Two (standard) or one (option 001) type N female connector(s) used to connect the Simulator channel(s) to an RF signal provided by a Transmitter. Provides the input signal for the Receiver(s) under test. Nominal input level is -10 dBm. Maximum input level is +20 dBm. Nominal input impedance is 50 Ω .
4. FRONT PANEL RF OUTPUT CONNECTORS. *Not available for option 002 or 003.* Two (standard) or one (option 001) type N female connector(s) used to connect the Simulator channel(s) to the Receiver(s) under test. Provides the conditioned input signal to the Receiver(s) under test. Nominal output power is -35 dBm. Maximum reverse input level is +20 dBm. Nominal output impedance is 50 Ω .
5. FRONT PANEL LO INPUT CONNECTORS. *Not available for option 002 or 003.* Two (standard) or one (option 001) type N female connector(s) used to connect the Simulator channel(s) to a +10.0 dBm Local Oscillator input signal that is set to a frequency 6 MHz above or below the RF input (typically provided by an HP 8657B Synthesizer). Nominal input level is +10 dBm. Maximum input level is +20 dBm. Nominal input impedance is 50 Ω .
6. PARALLEL PRINTER CONNECTOR. A 36 pin (Centronics®) interface connector provides the operational control signals from the Vectra PC. Connection is made via the 2 meter HP 24542D mating cable or equivalent. All functions except LINE ON/OFF are controlled using the Vectra PC.
7. REAR PANEL LO INPUT CONNECTORS. *Not available for STD units.* Two (option 002) or one (option 003) type N female connector(s) used to connect the Simulator channel(s) to a +10 dBm Local Oscillator input signal that is set to a frequency 6 MHz above or below the RF Input (typically provided by an HP 8657B Synthesizer). Nominal input level is +10 dBm. Maximum input level is +20 dBm. Nominal input impedance is 50 Ω .
8. AUXILIARY LO OUTPUT CONNECTORS. Two (option 002) or one (option 003) type N female connector(s) used to provide an output of the LO #1/LO #2 input signal(s). Typical output level is +10 dBm.
9. REAR PANEL RF OUTPUT CONNECTORS. *Not available for STD units.* Two (option 002) or one (option 003) type N female connector(s) used to connect the Simulator channel(s) to the Receiver(s) under test. Provides the conditioned input signal to the Receiver(s) under test. Nominal output power is -35 dBm. Maximum reverse input level is +20 dBm. Nominal input impedance is 50 Ω .

10. REAR PANEL RF INPUT CONNECTORS. *Not available for STD units.* Two (option 002) or one (option 003) type N female connector(s) used to connect the Simulator channel(s) to a 0 dBm RF signal provided by a Transmitter. Provides the input signal for the Receiver(s) under test. Nominal input power level is -10 dBm. Maximum input level is +20 dBm. Nominal input impedance is 50 Ω .
11. TIMEBASE INPUT 10 MHZ CONNECTOR. BNC female connector is used to connect the 10 MHz TIMEBASE OUTPUT connector on the external Local Oscillator to the Simulator. Impedance is 50 Ω . Input level is 0 dBm to +20 dBm maximum.
12. LINE MODULE/SWITCH turns the instrument power supply on and off. Permits operation from 90 to 132 Vac and 190 to 264 Vac. The nominal line (mains) voltage for which the module is set to operate is indicated by the matching arrows (see Figure 2-1). The protective grounding conductor connects to the Simulator through this module. The line power fuses are part of this module and is the only part to be changed by the operator.

3-6. Local Operating Procedures

Procedures for Simulator System Transmitter and Receiver-under-test connection, and instructions for using each menu selection locally are provided. Refer to Chapter 2, Installation/Verification for system configuration, software installation, and turn-on procedures. Remote operation is described in paragraph 3-11, "Remote Operating Procedures".

1. Connect the Transmitter and Receiver under test to the Simulation System as shown in Figure 3-2.

Note



The standard instrument is shown in the following figure. Connection to instruments with options is the same, making connections on the rear panel in lieu of the front panel when necessary.

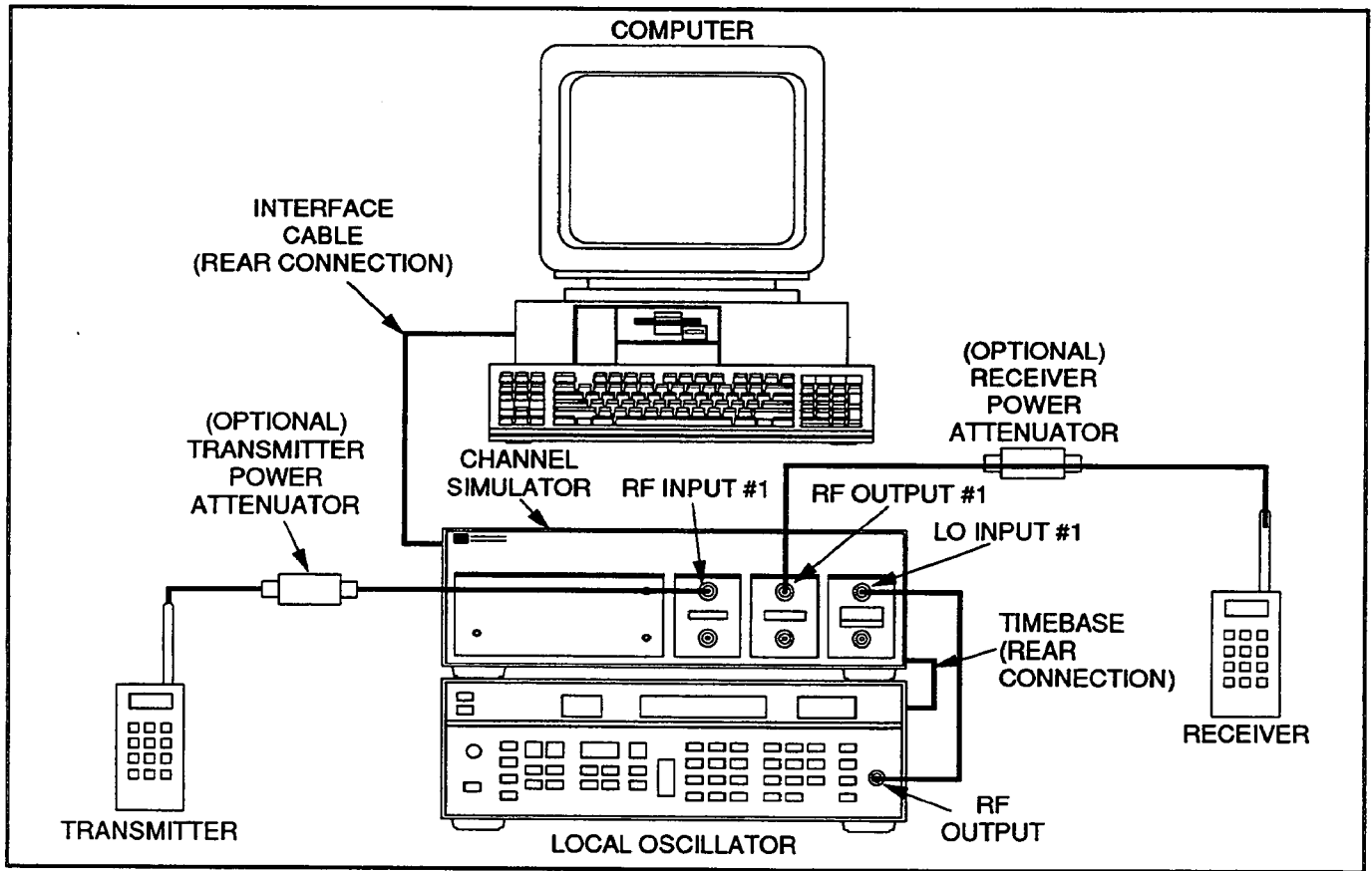

Figure 3-2. Simulation System Set-up

Note



A single Transmitter/Receiver combination connected to Channel 1 is shown in Figure 3-2. A number of different configurations can be used depending on the number of Transmitters/Receivers being tested and instrument options.

Note



Use the following guidelines when configuring the Simulator System for multiple channels (standard and option 002 only). Configuring two Simulator's for a 12-path system is also similar.

- **Diversity Systems** (one transmitter/two receivers): Connect the Transmitter to both the Simulator RF INPUT CONNECTORS (1 and 2) using a power splitter (HP P/N 11636A). Connect the Local Oscillator as shown in Figure 3-2. Using a Type N cable, connect the Simulator rear panel AUX LO#1 OUTPUT to the front panel LO INPUT #2. Connect the Receivers to RF OUTPUT #1 and #2.
- **Duplex Testing** (two transmitters/two receivers): Two Local Oscillators are required if testing at two different frequencies. Connect Local Oscillators, Transmitters, and Receivers to separate channels.
- **Co-Channel and Adjacent-Channel Testing** (two transmitters/one receiver): Connect the two Transmitters to both the Simulator RF INPUT CONNECTORS (1 and 2). Connect the Local Oscillator as shown in Figure 3-2. Using a Type N cable, connect the Simulator rear panel AUX LO#1 OUTPUT to the front panel LO INPUT #2. Connect the Receiver to RF OUTPUT #1 and #2 using a power splitter (HP P/N 11636A).

2. Set the power switches of the Transmitter and Receiver to ON/STBY. Do not key the transmitter at this time.
3. Set the Local Oscillator controls as follows:
 - Output Level +10 dBm
 - Frequency .. 6 MHz below the Transmitter Frequency (Channel)
4. Enter the correct input power level for the Simulator using the following guidelines:
 - The front panel Overvoltage LED's will light when channel power is above optimum levels, therefore best overall performance is provided when input power is such that the LED(s) just go out. Slowly increase power until the LED(s) just light, then decrease in 0.1 dB steps until the LED(s) go out. Typical RF power input is approximately -10 dBm, however actual optimum input RF power is determined by the RF frequency and signal waveform.

Caution



If the Peak output of the Transmitter is $> +10$ dBm (10 mW into 50Ω), a Power Attenuator must be installed between the input of the Simulator and the Transmitter output. Permanent damage can result if the input to the Simulator exceeds +20 dBm (100 mW into 50Ω).

5. If installed, set the Receiver Power Attenuator to a setting that will attenuate the Simulator RF output to the desired level.

6. Set the Transmitter to TRANSMIT the RF signal.
7. On the Vectra PC, CD to the CHANSIM directory and type 'CHANSIM' then press ENTER.
8. On the Computer, select the desired test (S/D/T). Other selections are available as follows:
 - H is used to display a list of possible installation difficulties.
 - C is used to modify the current configuration (e.g., directory assignments, interface port number, and instrument options). Select and follow instructions displayed on the screen.
 - Q is used to terminate the Simulation Software program.

Note

It is important to accurately measure the output power of any channel simulator. On the HP 11759C, it is best to use a frequency selective measurement. The most accurate method is to use a measuring receiver such as the HP 8902 in tuned RF mode. A spectrum analyzer can also be used, and its absolute power accuracy can be improved by calibration using a CW signal source and a power meter. When measuring either of the Simulator's RF outputs with a broadband power meter, it is important to follow the following steps to insure proper and accurate results.

The output spectrum present at the Simulator's RF OUTPUT(s) contains three signal components:

- The desired signal at a frequency equal to the RF INPUT frequency but attenuated by the 'PATH INSERTION LOSS' specification.
- Feedthrough from the Local Oscillator at a frequency equal to the Local Oscillator frequency but attenuated by the 'LO Feedthrough on RF output' specification (typically < -20 dBm).
- The image of the RF OUTPUT signal at a frequency equal to the RF OUTPUT frequency less 12 MHz. The image frequency will be equal in amplitude to the desired RF OUTPUT frequency.

For accurate power measurements, it is necessary to subtract the LO and image powers. The following procedure outlines the steps that will accomplish this.

1. Disconnect the RF INPUT signal.
2. Attach a power meter to the RF OUTPUT connector.
3. Measure the power present at the RF OUTPUT connector in dBm. This power level is the LO power and will be referred to as P_{LO} .
4. Connect the desired 0 dBm input signal to the RF INPUT connector.
5. Turn on the desired paths with the desired spectrum (Doppler, Rayleigh, or Phase).

6. Measure the power present at the associated RF OUTPUT connector in dBm. This power level will be referred to as P_{tot} .
7. Use the following equation to calculate P_{sig} , the actual power present at the desired frequency.

$$P_{sig}(dBm) = 10\log[10^{\frac{P_{tot}}{10}} - 10^{\frac{P_{lo}}{10}}] - 3$$

Effect of Local Oscillator and Image Signals Upon Bit Error

Although the power present in the LO and image signals will affect a broadband power measurement, they will not affect a BER measurement when using a typical receiver. This is due to the inherent filtering present in the receiver under test.

3-7. Simulation Tests

There are three Spectrum modes (Rayleigh, Doppler, or Phase) that simulate the fading response of a channel. Each mode performs as follows:

- **Rayleigh Spectrum Mode:** This mode simulates the fading response of a channel using the Rayleigh model defined for mobile cellular radio.

For standard and option 002 instruments, two independent channels are available for simulation, each with three signal paths. Channel 1 is paths 1-3, and channel 2 is paths 4-6. Delay, Doppler, and Attenuation parameters for each path are locally or remotely selectable.

For option 001 or 003 instruments, only one channel is available for simulation, with six signal paths. Delay, Doppler, and Attenuation parameters for each path are locally or remotely selectable.

In addition, the Rayleigh Amplitudes of paths 1-3 may be correlated with the respective path pair (4-6). The three path pairs that can be independently correlated are paths 1 with 4, path 2 with 5, and path 3 with 6. In 12-path configurations (dual Simulator arrangements), the additional six path pairs that can be independently correlated in a separate mode are paths 1 with 7, path 2 with 8, path 3 with 9, path 4 with 10, path 5 with 11, and path 6 with 12.

The correlations are only valid if both paths of the pair are in Rayleigh Spectrum mode. If either path of the pair is not in Rayleigh Spectrum mode (Off or Doppler, or Phase), parentheses are placed around the correlation factor in the table to indicate that the paths are uncorrelated.

- **Doppler Spectrum Mode:** This mode simulates the static Doppler effect that occurs when a mobile is in motion relative to the base station.

For standard and option 002 instruments, two independent channels are available for simulation, each with three signal paths. Channel 1 is paths 1-3, and channel 2 is paths 4-6. Delay,

Doppler shift, and attenuation parameters for each path are selected by the user.

For option 001 or 003 instruments, only one channel is available for simulation, with six signal paths. Delay, Doppler, and Attenuation parameters for each path are selected by the user.

- **Phase Spectrum Mode:** This mode allows static control of the phase of a path, where phase shift is entered in degrees.

Note



If the phase spectrum is to be used with non-zero delays, it is important to accurately enter both the RF and LO frequencies for the channel. The delay at the IF frequency introduces additional phase shifts which are subtracted by the control software based on the value of RF-LO.

To configure the Simulator System for a Simulation Test, proceed as follows:

1. From the main menu, select "S". Verify the Computer display is similar to the following:

DATA SHOWN IN SCREEN FOR EXAMPLE ONLY

HP11759C Channel Simulator Rev 3.26
CHANNEL SIMULATION TEST

RESET

| | CHAN 1 RF: 900.000000 MHz LO: 894.000000 MHz | | | CHAN 2 RF: 900.000000 MHz LO: 894.000000 MHz | | |
|-----------------------------|---|-------------------|-------------------|---|-------------------|-------------------|
| | Path#1 | Path#2 | Path#3 | Path#4 | Path#5 | Path#6 |
| Spectrum: (file name) | OFF | OFF | OFF | OFF | OFF | OFF |
| Delay: | 0.0 km 0.0us | 0.0 km 0.0us | 0.0 km 0.0us | 0.0 km 0.0us | 0.0 km 0.0us | 0.0 km 0.0us |
| Doppler or Phase: | 0.0 kmh 0.0 Hz | 0.0 kmh 0.0 Hz | 0.0 kmh 0.0 Hz | 0.0 kmh 0.0 Hz | 0.0 kmh 0.0 Hz | 0.0 kmh 0.0 Hz |
| Atten: | 0.0 dB | 0.0 dB | 0.0 dB | 0.0 dB | 0.0 dB | 0.0 dB |
| Correlations: (Rayleigh) | To Path 4 | To Path 5 | To Path 6 | (0.0) | (0.0) | (0.0) |

(more paths) -->

[ARROW KEYS] Move [ESC] Exits Sets SPECTRUM to turn path ON or OFF
[ENTER] Sets Value [CTRL] [BACKSPACE] Resets [ALT-P] Save/Recall Profiles

Note



The following keys may also be used to position the cursor:

- | | |
|-------------|---|
| Home | to upper left |
| Tab | moves left to right, top to bottom |
| <shift>-Tab | moves right to left, bottom to top |
| Back Quote | Changes Spectrum mode between Doppler and Off |

2. Use the arrow keys to move the cursor to the CHAN 1 box, then press of the ENTER key. A box will be displayed, allowing entry of the parameter (information about the parameter is also displayed). Enter the desired RF and/or LO frequency (from

40.0 to 2700.0 MHz) for the simulation, then press ENTER to set the value. Repeat for Channel(s) #2, #3, and/or #4 if necessary.

Note



Limits can be display for most fields by entering a large out-of-range value, such as 99999 and pressing ENTER.

Enter the RF freq in MHz & press [Enter].

- Use the arrow keys to move the cursor to the SPECTRUM box of the desired PATH#, then press the ENTER key. A box will be displayed, allowing selection of OFF, RAYLEIGH, DOPPLER, and PHASE parameters (information about the parameter is also displayed). Use the arrow keys to select the desired test, then press the ENTER key.

Use arrow keys to choose the path 1 Spectrum type, & then press ENTER:

=====

| | |
|---|---|
| <p>--> OFF RAYLEIGH DOPPLER PHASE</p> | <p>OFF If OFF is chosen, this path will not pass any signal. Maximum attenuation & delay settings are set internally.</p> |
|---|---|

Note



When Rayleigh Spectrum mode is selected, one of the pre-configured Rayleigh Fading Data files that contains the data for various Doppler frequencies must be selected using the arrow keys. Once the desired file is selected, press ENTER to continue. Use the IQMAKE.EXE utility to build Rayleigh .IQ files. Type IQMAKE -H from the DOS prompt for more information.

- Use the arrow keys to move the cursor to the DOPPLER/PHASE box of the same PATH#, then press ENTER key. A box will be displayed, allowing entry of the parameter (information about the parameter is also displayed).

Enter the Doppler (kmh) for path #1 & press [Enter]. The fixed DOPPLER shift = (VehicleSpeed)*(F_rf)/SpeedOfLight, where F_rf is the RF frequency for this path.

Note



When Rayleigh Spectrum mode is selected, Doppler/Phase values cannot be entered. Changing values can only be accomplished by selecting a new Rayleigh Spectrum File.

- For Doppler, enter the desired speed (from -509.6 to +509.6 km/h) or Doppler shift (from -425.0 to +425.0 Hz), then press ENTER to set the value. Entering Hz automatically changes the kmh value and vice-versa. This conversion is based on the Channel RF Frequencies previously entered (step 2).
- For Phase, enter the desired phase shift of the Receiver (from -360.0 to +360.0°), then press ENTER to set the value.

Note



Doppler shift Hz/kmh conversions are as follows:

Convert the entered Doppler shift frequency into the equivalent vehicle speed to cause that shift. By substituting the equation for $Wavelength = (SpeedOfLight / Fcarrier)$ into the Doppler freq shift equation $FDoppler = Velocity\ of\ vehicle / Wavelength$. Also, the result is scaled based on the passed in value of the carrier frequency, which is the frequency in Hz into the front panel of the HP 11759.

The resulting Doppler frequency is:

$$FDoppler = \frac{VelocityofVehicle}{Wavelength} = \frac{VelocityofVehicle}{(SpeedOfLight / Fcarrier)}$$

Simplifying,

$$FDoppler = \frac{(VelocityofVehicle) * (Fcarrier)}{SpeedOfLight}$$

Solving for Velocity of Vehicle,

$$VelocityofVehicle = \frac{FDoppler * SpeedOfLight}{(Fcarrier)}$$

So, for a Carrier frequency of 900 MHz, Velocity kmh=

$$= \frac{(FDopplerhz) * [(299.792E6meters/sec) * (3600sec/hr)]}{[(900MHz) * (1E6Hz/MHz)] * (1000meters/km)}$$

Convert the Vehicle velocity's Doppler shift into the equivalent Doppler frequency shift. By substituting $Wavelength = (SpeedOfLight / Fcarrier)$ into $FDoppler = Velocity\ of\ vehicle / Wavelength$, the Doppler frequency is:

$$FDoppler = \frac{VelocityofVehicle}{Wavelength} = \frac{VelocityofVehicle}{(SpeedOfLight / Fcarrier)}$$

Simplifying,

$$FDoppler = (VelocityofVehicle) * (Fcarrier)$$

So, for a Carrier frequency of 900 MHz, FDoppler Hz=

$$= \frac{[(Carspeedkmh) * (1000meters/km)] * [(900MHz) * (1E6Hz/MHz)]}{[(299.792E6meters/sec) * (3600sec/hr)]}$$

5. Use the arrow keys to move the cursor to the DELAY parameter of the same PATH#, then press ENTER key. A box will be displayed, allowing entry of the parameter (information about the parameter is also displayed). Enter the desired value (will be displayed in the box), then press ENTER to set the new value. The following parameters can be entered for each path:
 - Delay to the Receiver. Select and enter in either kilometers from -55.81 to +55.81 km) or microseconds (from -186.18 to 186.18 μ s). Entering one automatically changes the other.
 - Delay Resolution. Press the TAB key. A box will be displayed, allowing selection of HIGH or LOW resolution parameters (information about the parameter is also displayed). Use the arrow keys to select the desired delay resolution, then press the ENTER key. Selecting and modifying one path changes all paths.

| | |
|---|--|
|  | Enter the Delay (us) for path #1 & press [Enter]. The entered delay time, in microseconds, is applied to that part of the signal which passes through this path. |
| Delay resolution is set to LOW. Press TAB key to change. | |

Note



Delay Hz/kmh conversions are as follows:

Convert the microseconds of delay to the equivalent distance in kilometers, using this equation for a signal prop delay thru free space, in which general form is "Distance = time * Speed of light":

$$Delay_{km} = Delay_{us} * (299.792E^{+3} km/sec)$$

Convert from kilometers of delay to microseconds of delay using the following signal prop delay Time = (Distance/) (Speed of Light) equation for a signal in free space:

$$Delay_{us} = Delay_{km} / (299.792E^{+3} km/sec)$$

Note

When operating in the Spectrum Phase setting, the initial resulting output phase of the instrument at a setting of 0 degrees will differ for LOW and HIGH Delay resolution settings. Normally, one mode is selected and set to 0 delay and 0 degrees phase to establish a reference for future settings.

The following paragraph applies to software revision 3.28 and above.

If any of the path delay values are negative, then all path delays are internally increased by an amount equal to the absolute value of the most negative delay. For example, if path 1 is $5 \mu\text{s}$, path 2 is $-8 \mu\text{s}$ and all other (non-off) paths are zero, then path 1 delay will be internally set to $5 - (-8) = 13 \mu\text{s}$, path 2 will be internally set to $-8 - (-8) = 0 \mu\text{s}$, and the others to $0 - (-8) = 8 \mu\text{s}$. The display will still show the original entered delays of 5, -8 , and 0.

6. Use the arrow keys to move the cursor to the ATTENUATION parameter of the same PATH#, then press ENTER key. A box will be displayed, allowing entry of the attenuation of the signal from the Transmitter to the Receiver (information about the parameter is also displayed). Select and enter in dB (from 0 to 50 dB), then press ENTER to set the new value.



Enter the Attenuation (dB) for path #1 & press [Enter]. The entered value is applied to that part of the signal passing through this path. 'dB' is relative to the other channels of the same spectrum type. Phase and Doppler paths are NOT relative to Rayleigh or I/Q spectrum paths.

Note

Normally one path is set to 0 delay and 0 dB attenuation to establish a reference path for the other paths.

7. When Rayleigh Spectrum Mode is selected, use the arrow keys to move the cursor to Correlations of the same PATH#, then press ENTER key. A box will be displayed, allowing the user to choose the parameter (information about the parameter is also displayed). The following parameters can be entered for each path:
 - Single Simulator arrangement. Select correlation then press the TAB key. Use arrow keys to select NONE for no correlation, or 3X3 to perform correlation on the respective path pairs (1 to 4, 2 to 5, or 3 to 6). Selecting a new correlation mode changes the mode for all the configured channels. Press ENTER key to choose the correlation mode, then enter correlation factor (from 0.0 to 1.0) for the selected path pair. When choice has been entered, press ENTER key to enter the correlation factor for that path pair.

- Dual Simulator arrangement. Select correlation then press the TAB key. Use arrow keys to select NONE for no correlation, 3X3 to perform correlation on the respective path pairs (1 to 4, 2 to 5, 3 to 6, 7 to 10, etc), or 6X6 to perform correlation on the respective path pairs (1 to 7, 2 to 8, etc). Selecting a new correlation mode changes the mode for all the configured channels. Press ENTER key to choose the correlation mode, then enter the correlation factor (from 0.0 to 1.0, in 0.1 increments) for the selected path pairs. When choice has been entered, press ENTER key to enter the correlation factor for that path pair.

| | |
|---|---|
|  | <p>Enter the Correlation Factor for path #1 & press [Enter]. It sets magnitude correlation between path 1 and path 4, when BOTH of these paths are of Rayleigh or I/O Spectrum.</p> <p>Correlation mode is 3 paths by 3. Press TAB key to change.</p> |
|---|---|

- Repeat steps 2 thru 7 until all desired path parameters are entered.
- The Simulator will begin signal simulation for each path as soon as the SPECTRUM parameter is entered. Thereafter, any change to any path parameter is immediately made to the specified path.
- Other functions are selected as follows:
 - To disable a path, use the arrow keys to place the cursor in the SPECTRUM field of the desired path column, and press "ENTER", choose "off" and press "ENTER".
 - To reset the values on all paths, press "CTRL-BACKSPACE". Reset state pictured on page 3-9.
 - To save the existing simulation profile on disk, or to recall predefined or previously saved profiles, press "ALT_P" and follow the instructions.

Note



When recalling a Simulator standard profile from disk, the filename containing the Rayleigh fading data must be chosen. Refer to step 3 for information on selecting Doppler. A Table of Standard Profiles is contained in Appendix C.

- To exit the Channel Simulation Test, press "ESC".

3-8. Travel Test

The Travel Test simulates the faded response of a signal with multiple paths, and a moving receiver, or a stationary receiver/transmitter and single moving reflector.

- For standard and option 002 instruments, two independent channels are available for simulation, each with three signal paths. Channel 1 is paths 1-3, and channel 2 is paths 4-6.
- For option 001 and 003 instruments, one channel is available for simulation, with six signal paths (1-6).

The user selects the placement of the Transmitter and all reflectors. Attenuation for each reflector can also be entered.

Note

The RF input and LO input frequencies are the same for both channels for a Travel Test simulation.

During the Travel Test, reflectors 1-6 are actually paths 1-6. Reflectors 1-3 are on channel 1, and reflectors 4-6 are on channel 1 (options 001 and 003) or channel 2 (standard and option 002).

If all six reflectors are being used on standard or option 002 instruments:

- Connect the Transmitter to both the RF CHANNEL INPUT #1 and #2 connectors using a Power Divider/Combiner, such as the HP 11636A.
- Connect the Receiver to both the RF CHANNEL OUTPUT #1 and #2 connectors using a Power Divider/Combiner, such as the HP 11636A.
- Connect the rear panel AUX LO Output to the LO IN #2 using low loss cable.

Use similar connections when using more than six paths during dual Simulator operation.

The save/recall feature of the Travel Test allows an entire simulation to be precomputed and saved to a disk file for use in a real time simulation. The steps are:

- The signal map is used to enter transmitter, receiver, and reflector locations and the loss of each reflector.
- The vehicle speed, and three attenuation parameters are entered.
- The option to save the setup is chosen.
- The time intensive computation of path attenuations at each vehicle position is computed and saved to a disk file, along with the signal map, vehicle speed, and attenuation parameters.

If the simulation is allowed to go to completion, then the simulation signal map arrangement and path attenuations for each simulation time may be recalled from disc (replay mode). This configuration is applied to the HP 11759 paths to simulate real time fading scenario.

Note

It is important to allow the Travel Test simulation to complete if the setup is being saved. The premature ending of the simulation will result in an incomplete Travel Test scenario, and the test will end before the vehicle can reach 15 km.

To configure the Simulator System for a Travel Test, proceed as follows:

1. From the main menu, select "T". The Computer will display:

DATA SHOWN IN SCREEN FOR EXAMPLE ONLY

```

HP11759[C/D] Channel Simulator Rev 3.26                                TRAVEL TEST
Copyright (c) Hewlett-Packard Co. 1993                                ACTIVE SETUP = "<DEFAULTS>"

===== TRAVEL TEST MAIN MENU =====
C: Create or Modify setup
L: Load setup from existing file
D: Load default setup
B: Build travel test file
R: Run simulation from file
H: Help
Q: Quit

Enter selection. . .

```

Note

"Active setup=" displays where the setup originated, either default parameters or the filenames. Modified is displayed if the setup has changed.

- Select "C" to create or modify the default or recalled Travel Test set-up. After selecting, proceed with step 2 for instructions.
- Select "L" to load the Travel Test set-up used on a previously executed simulation file. After selecting, use the arrow keys to choose the desired file then press ENTER key. Once selected the setup is recalled and the screen returns to the Travel Test Main Menu. If a previously executed simulation file is not available, an error is displayed.
- Select "D" to recall the default setup values. Once selected, the current setup is overwritten and cannot be recovered.
- Select "B" to run a simulation using the current setup and (if selected) store the simulation Travel Test set-up on disk. See step 11 for details.

- Select "R" to replay the previously saved Travel Test simulation. After selecting, use the arrow keys to choose the desired file then press ENTER key. Once selected the simulation is replayed, and when finished the screen returns to the Travel Test Main Menu. If a previously executed simulation file is not available, an error is displayed.
 - Select "H" is used to display the help screen.
 - Select "Q" to return to the main menu.
2. If "C" was selected, verify the Vectra PC display appear as follows:

DATA SHOWN IN SCREEN FOR EXAMPLE ONLY

| | |
|---|--|
| HP11759[C/D] Channel Simulator Rev 3.26 Copyright (c) Hewlett-Packard Co. 1993 | TRAVEL TEST |
| SIMULATION MODE: | |
| Choose the simulation mode. One of two possible types of simulation may be specified. They are: | |
| 1. MOVING RECEIVER | The receiver moves from the center of the signal map off to the right edge. |
| 2. MOVING REFLECTOR | The first path is programmed as a moving reflector such as an airplane. The receiver is left stationary at a (later specified) position on the signal map. |
| Enter the desired Mode (1 or 2). Current setting is 1, moving receiver: | |
| Enter 1 or 2, and then press RETURN to choose mode [ESC] for previous menu | |

- Select "1" for moving receiver. This simulates the receiver moving from the center of the map to the right edge of the screen.
 - Or, select "2" for moving reflector. This simulates a stationary receiver and moving reflector from the center of the map to the right edge of the screen.
 - Or, select "ESC" to return to the main menu.
- If "1" is selected, verify the Vectra PC display appears as follows:

DATA SHOWN IN SCREEN FOR EXAMPLE ONLY

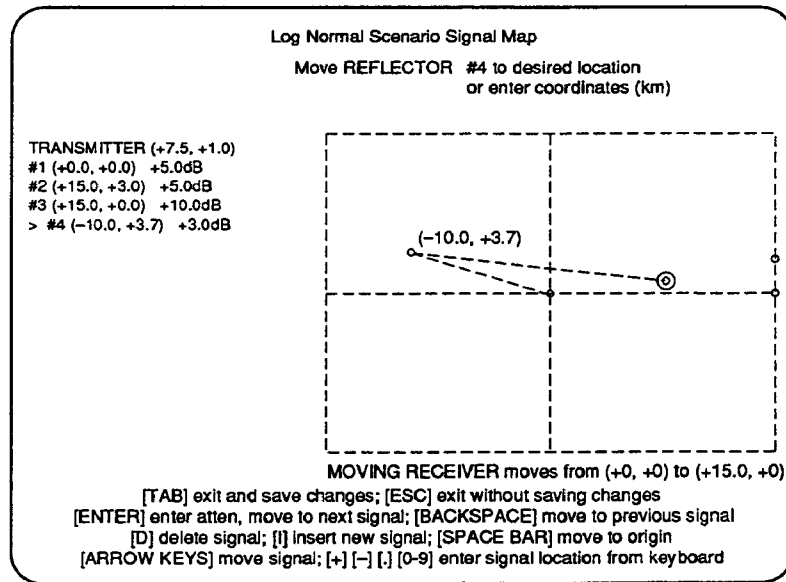

3. Use the arrow keys (or enter X/Y coordinates) to move the Transmitter to the desired location on the Channel Simulator Signal Map, then press ENTER to set the new position. The location is indicated by a bullseye on the map, and displays TRANSMITTER X/Y coordinates.

Note

X and Y coordinates may be entered numerically by typing the values and pressing the ENTER key.

4. If moving reflector was chosen (step 2), use the arrow keys (or enter X/Y coordinates) to move the Receiver to the desired location on the Channel Simulator Signal Map, then press ENTER to set the new position. The location is indicated by a bullseye on the map, and displays RECEIVER X/Y coordinates.
5. Use the arrow keys (or enter X/Y coordinates) to move the First Reflector to the desired location on the Channel Simulator Signal Map, then press ENTER to set the new value. The location is indicated by a circle on the map, and displays #1 X/Y coordinates.
6. Enter the desired Reflector Attenuation Constant (in dB) for the first Reflector, then press ENTER to set the new value.

Note

Each path Attenuation is limited to values between 0 and 50 dB. Path Attenuation is the combination of the gain offset, path loss (slope), Log Normal fading, and the individual reflector loss.

Out of range numbers displayed in the total attenuation field are followed by an "*".

7. Repeat steps 5 and 6 until all desired reflectors (from one to six, or 12 in dual Simulator arrangement) are positioned, and the desired attenuation for each reflector is entered.
 - To return the reflector to the origin (0,0) coordinates, press "SPACEBAR".
 - To move to previous signal, press "BACKSPACE".
 - To delete a signal, press "D".
 - To insert a signal, press "I".

Note

To simulate a direct line-of-sight path, place a reflector at the same coordinates as the transmitter.

8. When all desired reflectors are selected:
 - Press "TAB" to exit and save changes.
 - Press "ESC" to exit without making changes.
9. Enter the RF Frequency, then press ENTER to set the value and advance to the next parameter. The default value (in parentheses) will be accepted by pressing ENTER without selecting a value. The use of attenuation parameters can be pictured as follows:

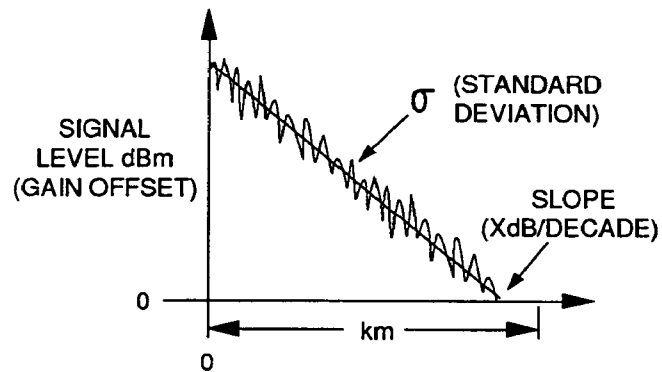

DATA SHOWN IN SCREEN FOR EXAMPLE ONLY

HP11759[C/D] Channel Simulator Rev 3.26 TRAVEL TEST
 Copyright (c) Hewlett-Packard Co. 1993 Active setup = "<DEFAULTS>"

LOG NORMAL SCENARIO PARAMETERS

RF Frequency (900) MHz:
 Speed (100) kmh:

The next three parameters are used along with the xy-distances to determine path attenuation during the simulation. These values, when combined with the signal propagation for each path, should always result in a total path attenuation within range for the path.

Since no limit checking is done on these parameters, the output attenuations will be clipped if this attenuation range is exceeded.

Path Loss Exponent (5) dB/decaded:
 Gain Offset (-10) dB:
 Log Normal Standard Deviation (8) dB:

- RF Frequency (900) MHz: Enter the RF channel frequency of the transmitter/receiver in MHz. Range is from 40 MHz to 2700 MHz. The default is the last value entered.

Note

An explanation can be displayed by entering a large out-of-range value, such as 99999 for the RF Frequency.

- Speed (30) kmh: Enter the desired speed of the receiver in kilometers per hour. Range is from 0.1 to 509.6 kmh, at the specified RF channel frequency. The maximum speed is limited by the largest of the two Channel RF frequencies. The actual Doppler Shift is a function of each channel's RF frequency (as specified in step 2). The default is the last value entered.
- Path Loss Exponent (0) dB/decade: Enter the simulated loss due to distance/atmospheric conditions in dB per decade kilometer. For example, a 3 dB setting is 3 dB loss at 10 Km, 6 dB at 100 Km, 9 dB at 1,000 Km, etc. Suggested range is from 0 dB to 30 dB/decade. The default is the last value entered.
- Gain Offset (-10) dB: Enter any additional overall system loss here. The number entered will affect the signal level of ALL reflectors (paths) equally. Normal Simulator operation should use -10 dB (gain of 10 dB). Suggested range is -10 dB (gain) to 20 dB (attenuation). The defaults is the last value entered.

Note

Gain Offset is normally used in situations where it is desired to add a common amount of attenuation to all paths.

- Log Normal Standard Deviation (8) dB: Enter the desired simulated log normal standard deviation on the signal from the

Transmitter to the Receiver. Select and enter a value from 0 to 8 dB. The default is the last value entered (indicated in parentheses).

Note

Pressing ESCAPE at any of the attenuation or speed prompts causes the cursor to backup to the previous parameter. Pressing ESCAPE at the RF FREQUENCY prompt causes the travel test to exit, returning to the main menu.

10. After Log Normal Standard Deviation is entered, the Computer will display:

OK? (Y/N)

- Select "N" to re-enter any mistyped parameters.
- Select "Y" to accept the listed parameters.

If "Y" is selected, the Computer will return to the Travel Test Main Menu.

Note

Selecting "Y" will write the new set-up data over any previously stored set-up data. The previous data will no longer be available.

11. To run the simulation using the current setup, select B from the Travel Test Main Menu. After selecting, the "Save to file while running?" prompt is displayed.

- Select "N" to run the setup without saving the simulation to disk.
- Select "Y" to run the setup and save the simulation to disk. Selecting "Y" causes the following prompts to display:
 - "Enter new file name" - enter the desired file name with a ".DAT" suffix, then press ENTER.
 - "Enter Title" - enter up to 30 alphanumeric characters for the title, then press ENTER to run and store the simulation.

12. The Simulator will begin signal simulation for each reflector (path) previously setup. The Computer will update and display the simulation values as they are downloaded from the PC to the Simulator's processing hardware. This precedes the actual simulation conditions being output as the receiver/reflector moves through its 15 kilometer journey.

DATA SHOWN IN SCREEN FOR EXAMPLE ONLY

| HP11759(C/D) Channel Simulator Rev 3.26 | | TRAVEL TEST | | | | | | |
|---|--------|-----------------------------|-------------|----------------|-------------------|-------|------------|--------------|
| Copyright (c) Hewlett-Packard Co. 1993 | | Active setup = "<DEFAULTS>" | | | | | | |
| PATH Num. | X (km) | Y (km) | LENGTH (km) | VELOCITY (kmh) | ATTEN (dB) OFFSET | TOTAL | DELAY (μs) | DOPPLER (Hz) |
| TR | 0.0 | 0.0 | | | | | | |
| #1 | 1.0 | 5.0 | 10.2 | -19.2 | | 2.9 | 34.0 | 16.0 |
| #2 | 3.3 | -2.2 | 7.9 | -83.0 | 3.0 | 0.0 | 26.4 | 69.4 |
| #3 | -2.2 | 1.4 | 5.2 | 84.6 | | 13.8 | 17.5 | -70.7 |
| #4 | -7.5 | -1.6 | 15.4 | 97.8 | | 22.1 | 39.9* | -81.8 |
| #5 | 5.7 | 0.0 | 11.4 | -100.0 | | 21.2 | 38.0 | 83.6 |
| #6 | 10.2 | 1.1 | 20.5 | -99.4 | 5.0 | 22.2 | 39.9* | 83.1 |

| | | | | |
|--------------------------|--|---------------------------|--|--------------------|
| Not saving to file | | PATH LOSS: 43.0 dB/Decade | | LOG NORM σ: 8.0 dB |
| PRESENT LOCATION: 0.0 km | | GAIN OFFSET: -10.0 dB | | SPEED: 100.0 kmh |

[ESC] Quit, return to TRAVEL TEST MAIN MENU.

- LENGTH – Current signal traversal distance (in kilometers) from the Transmitter to the moving Receiver, via the Reflector.
 - VELOCITY – Current relative speed (in kilometers per hour) of the signal with respect to the moving Receiver.
 - ATTENUATION – Current total signal attenuation (in dB) from the Transmitter to the moving Receiver, including path loss, fixed offset, and the randomized log normal fading at that simulation time.
 - DELAY – Current delay offset (in microseconds) from the Transmitter to the moving Receiver.
 - DOPPLER – Current Doppler shift (in Hz) from the Transmitter to the moving Receiver, via the Reflector.
 - PRESENT LOCATION – Current distance (in kilometers) that the Receiver has traveled (up to 15 Km) from the origin (0,0) out to the right side on the X-axis (15,0).
13. After 15 km is reached, the program will return to the Travel Test Main Menu. To terminate the test, press "ESC". The Computer will save partially completed simulation to the disk file, and then display the Travel Test Main Menu.

3-9. Dynamic Test

The Simulator's Dynamic Test provides a means of using a programmatically controlled or database specified scenario for generating a multi-path fading or ghosting simulation with the Simulator. Each path involved in the fading/ghosting characterization may be independently controlled on a timed basis using a data file.

- First, a data file is created which contains the settings for each path over time needed to generate a particular simulation.
- This file is then translated into a binary readable file using a separate utility program.
- Then, by selecting "Dynamic Test" from the Simulation software main menu, the settings described in the data file can be "played back" through the Simulator to generate the requested fading/ghosting simulation.

The Dynamic Test may be used to control the propagation characteristics of each path in the Simulator. Each group of hardware settings for the Simulator at any one interval in time is called a frame, and a finite number of frames can define a particular scenario. From frame to frame, one or all of the attenuation, delay and either Doppler or phase settings can be changed for each path. In addition to varying the delay and spectral characteristics of the signal, the output can also be systematically changed to model a dynamic situation. The number of frames per second is setable within limits based upon the controlling computer's processing capability and the requested number of individual settings.

File Format

As stated earlier, the Dynamic Test provides a means of generating time varying, multi-path fading/ghosting simulations that are completely set-up and controlled by user-specified database values. The binary file is called a data file (identified by a ".DAT" extension) is used to define each frame of path settings and control the hardware output. This data file has the same format as the data file created by the "B: Build travel test file" command in the Travel Test portion of the main Simulation menu, and controls the Simulator in a similar fashion. The main difference between a Travel Test .DAT data file and the one used by the Dynamic Test is that the file is not generated directly by the software system; it must be created and then translated by the user. This allows the user to create simulations using both measured data models and uniquely defined conditions.

A .DAT data file is actually a binary readable file that has been generated by translating an ASCII file containing a set of formatted commands. The translator is a utility called "ASCI2DAT.EXE", and is provided with the Simulator software. The translator converts an edited file of ASCII numbers into a binary .DAT file that is directly readable by the Dynamic Test. This file can then be used by the

Simulator Dynamic Test to program the instruments hardware paths during a simulation.

The ASCII file can be generated in a variety of ways. Using any convenient programming interface, the user can create a program to input the desired hardware settings into an ASCII file in the necessary format. If the number of frames in a simulation is relatively short, the user may choose to create an ASCII file directly with a text editor. However, for measured data, or simulations requiring a large number of frames, a program designed to process the data is typically used to generate the lengthy ASCII file. The ASCII file, when saved, needs to be named with a ".ASC" filename extension. A sample program containing five frames of hardware settings is provided in Appendix D.

The format of an ASCII file is broken up into two main regions: the Header and Data sections of the control program. The same two sections also appear in the translated data file, but the data section, having been translated into binary format, is no longer directly readable by the user. The Header contains all the set-up, configuration and data processing information plus any comments the user may choose to include. Some of the necessary entries include:

- the file identification listing (FILEID)
- the revision number (REV)
- a title
- the number of paths to be used (NPATHS)
- the hardware update rate (UPDATE RATE)
- the number of frames (NFRAMES) present in the Data section used to describe the simulation.

The Data region of the .ASC file contains the descriptive frames of the simulation. Each frame is separated by what is called a "wait" statement. A wait is implemented by the hardware in order to maintain the signal output at the specified update rate. The wait is flagged by the argument "S:" followed by a carriage return (the S stands for synchronize). During simulation, the hardware setting processing continues until the first wait statement is encountered. A longer wait can be inserted at any point in a file by adding a sequence of wait records.

Note

In the playback of a Dynamic Test file, a user may recall up to 80 individual files. After 80 files, the additional files created do not appear on the file browser menu for selection; a file would have to be removed in order for a new one to be made available for simulation.

A brief example of a .ASC file for one frame might be as follows:

```

FILEID:      ASCII                      # HP 11759 (C | D) Dynamic data file.
REV:         1.00
TITLE:       "PosIF, DOPpaths, CLOCK dlytype"
COMMENT:     Misc. documentation text; this is only a
             collection of up to 5 lines of comment text
             which gets copied from the ASCII file into
             the header of the .DAT file. It is not read
             or used by the HP 11759 Dynamic test
             simulation.

NPATHS:      3                          # 3 paths total are used, but path 2 will be off.
NFRAMES:     1                          # Only 1 frame is defined (Identified by only one
                                     #wait statement S:) Optional field.

UPDATE      10.000000                   # Sets of path parameters are updated at 10 Hz.
RATE:

3:RF FREQ:   900000000.0                 # The RF will be operated at 900 MHz during
                                     #test.
3:LO FREQ:   894654321.0                 # The LO will be 894.654321 MHz during
                                     #simulation.
1:SPECTRUM:  DOPPLER                     # Path one is "on", set to DOPPLER spectrum
                                     #type
3:SPECTRUM:  PHASE                       # Path 2 left off; this sets path 3 to PHASE
                                     #mode
#                                          # Comments may be put anywhere (except in
                                     #the title) using the "#" char
DATA:        # This denotes when the data settings part of
                                     #the file begins.

1:A          10                          # Path 1 attenuation in dB
1:D          20                          # Note that delay is in microseconds
1:F          -20                          # Doppler freq shift for path 1, in Hz.
3:A          12                          # Path 3 attenuation in dB
3:D          15                          # Path 3  $\mu$ s delay
3:P          32                          # Phase shift for path 3, in degrees.
S:          # Mark the end of one simulation time interval
                                     #with a wait statement.

```

The first two lines (FILEID and REV) should always appear as shown, otherwise the translator program may not recognize the file as valid. The title is optional, and it will be posted on the status screen during simulation if it is provided. There may be up to five comment lines which get copied over to the .DAT file for reference, but are not used or displayed during the actual simulation. NPATHS specifies the path number of the largest declared path. In the above case path 2 is unused, but it is counted when determining NPATHS since the

largest path number in SPECTRUM declarations is 3. The update rate declares the number of updates of a frame of hardware settings to the Simulator per second.

The numbers in column one are path numbers. The RF and LO frequencies (specified in Hz) for path 3 are entered precisely so that phase can be set correctly. In addition to delay and attenuation settings, path 1 spectrum type contains a Doppler shift, while path 3 has a static phase difference set. The "DATA" field name marks the end of the declaration header and the beginning of the path parameter settings. The field names in the first column (or after the path number if one exists) are for attenuation (A), delay (D), Doppler frequency (F), and phase (P) as indicated. The S: (a Synchronized "wait") shows the end of the first and only frame of parameter settings. A more complete listing of the .ASC data file command formats and a short description of each record type is listed in Appendix D.

.ASC File Line Format Requirements

Note



The maximum allowable number of lines for a file, including both the Header and Data sections is 2,147,483,647.

All of the command and description lines of the ASCII file must follow certain conventions regarding placement and the use of tabs, spaces and characters. They are as follows:

- The FILEID and REV field names must be the first two lines respectively in the Header.
- Field names must be followed immediately by a colon, and if a path precedes a field name, it too must be followed by a colon (Spaces are not allowed between the path colon and the field name).
- Spaces and tabs are allowed between the ending colon of the field name and the start of the line argument. However, any additional characters after a legitimate line argument entry will typically be ignored.
- Lines with a "#" in the first column are ignored, and may be used for comments. A line may be ended with a #. This allows comments to be inserted on the line after the main field name and commands.
- The # however, CANNOT be used within the TITLE. Any # within the title's double quotes will be changed to a "~" when the file is translated to a .DAT data file.
- Overall, the format is quite tolerant of extra spaces and tabs, leading spaces on a line are ignored.
- Each line should be terminated with either a carriage return <car> (ASCII 13) or line feed <lf> (ASCII 10) or both <cr><lf>.

- Blank lines are ignored, and the translator utility is not case sensitive.
- Operational range limits for delay, attenuation, Doppler and phase are the same as those specified for the static Simulation mode (See Appendix A for an abbreviated listing of operational specifications).
- Number ranges that are either below the acceptable values or are of higher precision than what is supported by the system, will either be rounded or truncated to zero by the translator.

Note

The system does not produce a warning or error message when such truncation or rounding occurs.

Characteristics of Operation

Unlike operation of the Simulator in a static operating mode, the Dynamic Test allows the user much more control over the hardware settings assigned to each path of the Simulator. Because such an extended depth of control of the instrument is permitted, successful operation of the Dynamic Test relies upon a knowledge of several important features and limitations of the Simulator. The first of these operational features is the fact that the spectral usage of a path may be controlled in one of three different ways. These spectral modes of operation effect the characteristics of the signal through each path. The three modes are:

- An OFF state
- Spectral Doppler mode
- Spectral phase mode

If a path is going to be used at any time during a simulation, it must be initialized in either the Doppler or phase modes.

Note

Unless otherwise declared in the .ASC file Header, the default spectrum mode for a path is OFF.

The OFF spectrum mode halts the processing done by the path's internal hardware, and the path is not usable in that particular simulation. If the path is needed at any time during the simulation, it must be made active initially by declaring it operational in either a spectral Doppler or phase mode. This is true even if the path is only needed for a very small time interval during the simulation. The contribution of the path when it is not being used can be minimized by setting it to a level of maximum attenuation (50dB). A path that is not OFF however, will still exhibit some RF feedthrough and contribute slightly to the overall signal output, even if set at maximum attenuation (See the Simulator Specifications and Appendix A for the isolation specification).

The Doppler spectrum mode is identical to the static Doppler setting mode in the main Simulation software menu. With the Dynamic Test however, the shift in frequency may now be changed over time during a simulation without any interruption in the signal. The phase spectrum mode is also the same as the phase setting mode in the static Simulation software menu; it provides a known phase shift in degrees through the simulation path relative to a known, normalized reference of 0 degrees. As is the case in the Simulation menu, the phase is set correctly, even in the presence of path delay. Internally, this is accomplished as follows: if the delay is nonzero, the phase is set in a 3-step process. First, the requested microseconds of delay is set using the path FIFO (First In, First Out) delay element in each path. The phase change resulting from the delay through the FIFO is then computed. The I/Q modulator is then set to provide the correct overall signal phase shift required, taking into account the phase shift caused by the delay in the FIFO. Because of the filtering between the control DAC and the I/Q modulator, a programmed phase change is not instantaneous (For more information, refer to the Block diagram and discussion in the Principles of Operation section of the manual).

The control of the level of attenuation is the same for both static and Dynamic Test operation. The attenuation range is still 0-50 dB, however during a dynamic simulation, it can typically take up to 0.4 seconds to change from one attenuation setting to another. One operating limitation is the inability to simulate Rayleigh fading with the Dynamic Test. Fading characteristics similar to those found in the random nature of a Rayleigh profile can be obtained by varying, (within the bandwidth limitations of the I/Q modulator) the phase setting of a path over time. However, the dynamic Rayleigh fading model in itself can only be activated through the main Simulation software menu. Also, the operation of setting up correlation between paths is not available using the Dynamic mode.

The Dynamic Test is capable of running user-created data files, as well as those created by the Travel Test (See the Travel Test description for further information). The resulting files have the same format; the Travel Test can actually be considered a sub-set of the Dynamic Test, with applications directed specifically towards mobile conditions.

Note

Simulations using the Travel Test may only model a single moving reflector or receiver, while a file created for the Dynamic Test may have up to 6 (or 12 if two instruments are being used) dynamically changing paths.

In a Travel Test file, only one delay mode is used to create relative delay between paths. The delay in the Dynamic Test however, can be set in one of three ways using the delay FIFO in each path. Selection of a delay mode should be based upon the delay range and resolution required by a particular simulation.

These modes are:

- High resolution
- FIFO Depth (low resolution)
- Clock

In High resolution mode, delay lengths of 0 to 186 μ seconds are possible, with 1 nsecond resolution. The absolute delay through a path at a 0 second delay setting is minimal in High resolution mode because the FIFO is initially set to minimum depth. In High resolution delay mode, both the depth of the FIFO and the sampling clock frequencies are varied to provide the range of delay values with 1 nsecond resolution. In FIFO depth mode, the range of available delay settings is the same: 0 to 186 μ seconds, but with only 50 nsecond resolution. This is because delay is created using a fixed clock rate, and only the depth of the FIFO is varied to create the required time value. The absolute delay through a path is also minimal for a 0 second setting (typically 560 nseconds for both High and Low delay modes).

Spectrum Operating Modes

| Mode | Available Settings |
|---------|--|
| OFF | No usage of the path |
| DOPPLER | Attenuation, Delay (in High resolution, Depth and Clock modes), Doppler frequency. |
| PHASE | Attenuation, Delay (in High resolution, Depth and Clock modes), Phase in degrees |

Delay Setting Modes

| Mode | Delay Range | Resolution | Characteristics of Operation |
|-----------------------|-------------|-----------------|--|
| DEPTH0-186 μ sec | | 0.050 μ sec | Fixed sample clock (22MHz), variable FIFO depth. FIFO set at its minimum depth, therefore ate path delay is low (560 nsec t1). Loss of data in FIFO when dsetting is changed. Phase normalization maybe required. |
| HIRES 0-186 μ sec | | 0.001 μ sec | Variable sample clock: (22-28MHz), variable FIFO depth. FIFO set initially at its minimum depth, therefore absolute path delay is low (560 μ sec typical). Loss of data in FIFO when delay setting is changed. Phase normalization maybe required. |
| CLOCK0-39.9 | | 0.001 μ sec | Variable sample clock: (22-28MHz), fixed FIFO depth. FIFO set at its maximum depth, therefore absolute path delay is high (146 μ sec typical). No loss of data when delay setting is changed. Possible increase in spurious. Phase normalization required. |

Note



Negative delay settings are not permitted in any of the modes.

In Clock mode, the 1 nsecond resolution of High delay mode is available, but the available delay range is only 0 to 39.9 μ seconds. In this mode, the FIFO is fixed at it's maximum depth, and delay variations are achieved by changing the sample clock. The clock is varied between the Fnom (typically 22 MHz) and Fmax (typically 28 MHz) settings specified in the Simulator's Configuration file (For more information, consult the Installation section of the manual). Because of the maximum FIFO depth being used, this mode has a long absolute path delay at a 0 second setting (typically 146 μ seconds of total delay). One advantage to delays created using Clock mode is that a change in the delay setting for a path will not result in a loss of simulation data. In resolution modes that vary the FIFO depth to create delay, all current in-process simulation data already stored in the FIFO must be cleared and the FIFO re-filled with new data to the new delay level. In Clock mode, the FIFO remains at a fixed depth, so data is not lost as the delay in a path is varied over time. However, because the clock is being varied unpredictably between 22 and 28 MHz, the spurious response can worsen due to aliasing or variations in bandwidth. Clock mode is used exclusively in the Travel Test, but with the Dynamic Test, any one of the three available delay modes can be user specified.

Note

Because of the varying FIFO depth and clock settings used by the different delay modes, and the resulting changes in absolute delay through a path, phase calibration is required when a path is to be operated in phase mode. At a 0 degrees setting, the initial output phase of a path will differ in Clock mode from that seen in either a static operating mode or operation in either High or Depth resolution modes. Thus, in order to maintain a understandable, true 0 degrees fixed reference for additional phase settings, the resulting phase must be calibrated out through normalization. This can be done by turning on a path and measuring the actual output phase at the desired RF operating frequency. This measured phase can be used as a starting point, from which all other phase settings are referenced. If desired, this value can be subtracted out from all measured phase data to establish 0 degrees as a reference.

In addition to the operating mode (Doppler, phase or OFF), other available user-defined settings are the number of paths being used, the number of frames making up a simulation and the RF and LO simulation frequencies. The system configuration is set when the model number is specified using the Configuration ("C") option from the Simulation software main menu, and it is important to remember that the configuration limits the settings permitted within a simulation. For example, a data file designed for a simulation using a 12 path configuration cannot be used with a system set-up for only 6 paths. (See the Simulator specifications and operating instructions for further information). The number of paths specified in a simulation must be greater than or equal to the number of contiguous paths used in the simulation. For example, if paths 1-3 and 5 were turned on, but path 4 was forced into an OFF state, the total number of paths used is considered to be 5 and at least this amount should be specified by the user in the NPATHS field block. If the number of paths used is not explicitly specified, the software will default to the number of paths actually being used in the simulation. The Travel Test requires that all paths be used sequentially in a simulation; a break in the numbering is not done.

The number of frames comprising a simulation is both specified by the user and counted by the translation utility during translation. When translation of the ASCII file is complete, a message is displayed comparing the number of frames listed versus those counted. If the number of software tabulated frames does not equal the amount entered in the data file by the user, a warning note is produced. The user specified number of frames given in the .ASC file, and not the counted value is used to calculate the "Percent Downloaded" displayed on the screen as the simulation is being run. Because the user-specified value is used, an incorrectly entered value will result in an erroneous "Download Complete" percentage. A mis-match in the number of frames listed and counted will not however, interfere with the execution of the simulation.

The RF and LO operating frequencies must be set precisely for a simulation channel in order to set the phase difference between paths accurately when operating in phase mode. If the unit has two channels (STD and OPT 002) the RF and LO frequencies can be specified for any one of the paths in the channel, and are then set for the entire channel. As it is for the case of static simulations, it is not possible to have more than one input RF frequency for any one channel. The pair of frequencies assigned to the last path specified, will dictate the frequencies used for the entire channel. That is, if an RF and LO are specified for both paths 1 and 3, the frequencies listed for path 3 will be used for the entire channel. This is also true for 6-path, single channel units (OPT 001 and 003). If no frequencies are specified at all, the default values of 900 MHz and 894 MHz will be used for the RF and LO respectively.

Note

A recommended convention is to always set the frequencies to correspond to the number of the first path (per channel) in the box to be used in a simulation. If multiple frequency assignments are made within a channel, the translator will not produce a warning indicating this fact or what frequencies will actually be used upon simulation.

One other parameter that can be specified for a Dynamic simulation is the update rate for the defined frames. The range of allowable update rates is 1 Hz to 2.3 kHz, with a default rate of 10 Hz, equal to that used in the Travel Test. Data can be read directly from the system's hard disk or from a fast ram disk, depending upon how the Configuration menu is set up (See the Installation section of this manual for further information). There are trade-offs however, between the allowable update rate, the number of paths or settings per path included in each frame, and the location of file storage. These trade-offs will be discussed further in the "Dynamic Test Simulation" section.

Translation of ASCII.ASC files to Dynamic Test .DAT files

Once a .ASC file has been created or edited in the proper format, it must be processed by the translator to generate a Dynamic Test .DAT file. Working in the DOS operating system of the PC, follow these steps to invoke execution of the translator:

1. Change to the directory (type "cd") where the CHANSIM software was installed (default = C:\CHANSIM).
2. Type "ASCI2DAT [ASCII file name].ASC [Data file name].DAT."

This command will result in the translation of the .ASC file called [FileName].ASC and creation of a new file - a Dynamic Test data file entitled [FileName].DAT which can now be used by the Dynamic Test software to control the Simulator hardware and generate simulations.

The command "ASCI2DAT" is not case sensitive, and has several usage format options:

USAGE: ASCI2DAT [-o] [-w] AsciiFileName DatfileName

-or- ASCI2DAT -d | more

-or- ASCI2DAT -p AsciiFileName DatfileName | more

where:

'AsciiFileName' names the DOS ASCII Text file which contains numbers that are to be converted into a binary DAT file.

'DatfileName' is the DAT file where the converted data is to be written. This should end with a .DAT suffix.

-d ..Print a full description of this utility to the display.

-p ..Preview parsing without writing; also shows all possible errors.

-o ..Overwrite the .DAT file if it already exists, without asking. The default action is to ask for confirmation before overwriting.

-w ..Suppresses warnings that would otherwise be printed to the monitor.

—> Type: ASCI2DAT -d | more for a full description of this utility.

Command line options must be one of -d, -o, or -p.

For an ASCII .ASC file containing X number of frame records, the following would be displayed after the translation is complete and the .DAT file has been generated:

```
HP 11759[C/D] Channel Simulator, Rev 3.26
Copyright © Hewlett-Packard Co. 1993
ASCI2DAT Translator
```

```
NOTE: Found X S: records, which agrees with NFRAMES count.
Translation completed.
```

If there are any format or range errors in the .ASC file, an error message or note indicating the status of the translation process will be displayed instead of the note given above. For example, if the number of frames listed after the NFRAMES field name did not equal the number of S: wait statements in the file, the following note would result:

```
NOTE: Found [more/less] S: records (Y found) than NFRAMES
value of X.
Translation completed.
```

If the optional NFRAMES field were left out of a file completely, the following note would be output:

```
NOTE: X "wait" S: frame records in ASCII file; no NFRAMES
record found.
Translation completed.
```

As was stated earlier, a mis-match in the number of NFRAMES does not prevent a file from being generated or used by the Dynamic Test. Other errors however, such as the usage of unspecified range values, incorrect file format or misspellings, will produce an error message and terminate the translation process. This error message will describe the type of error that was found by the translator, where it is located in the file, and an error number. The error number is only a means of identifying the occurrence of an error, is it not meant to be a reference code to aid in correction. As an example of a specification range error, an attenuation setting of 60 dB would produce the following error message:

ERROR: Attenuation (dB) was greater than the allowed 0.0 to 50.0 range.

Error was noticed at line #38 of the input file (ERROR 1).

Line:"1:A:60 # Path 1 attenuation of 60 dB".

Translation terminated in an incomplete state (9).

Other error examples include operating mode violations, exceeding configuration limitations or improper input frequencies. For example, if path 3 in the above example (declared in the spectrum phase mode), were defined with a Doppler frequency (F) instead of a phase (P), the following error would result:

ERROR: A "F" Doppler setting was attempted on a non-Doppler path (path 3).

Error was noticed at line #46 of the input file (ERROR 20).

Line: "3:F: 30"

Translation terminated in an incomplete state (9).

Improper frequency assignment might be the assignment of RF and LO input frequencies that have a bandwidth greater than the allowed 3-9 MHz range:

ERROR: The setup parameters for HP 11759 #1 (path 1 through 6) in the header of the ASCII file can not be used.

The .DAT file LO Frequency value is too far below the RF Frequency.

Translation terminated in an incomplete state (6).

A failure to meet configuration requirements might be the use of path number "12" in the data file for an instrument configured for only six paths:

ERROR: Path # was greater than allowed 1.0 to 6.0 range.

Error was noticed on line #5 of the input file (ERROR 1)

Line: "12:SPECTRUM:PHASE"

Translation terminated in an incomplete state (5).

For a majority of the types of errors that may occur during translation, the user must edit the original program used to generate the .ASC file, or the .ASC file itself to correct the error, and then rerun the translator. However, if the name of an already existing file is to be re-used to generate a new file, the translator will by default, prompt the user and ask if the file should be overwritten. The

"-o" option can also be used to tell the translator to automatically overwrite the file without a prompt.

A listing of most of the possible resulting error codes and their corresponding reference numbers is given in Appendix G.

Configuration Compatibility

If a file has been translated using a particular hardware set up, in order to run this simulation on another "target" system using a different configuration set-up, the data file must call out a sub-set of the allowable settings for the new configuration. In some cases however, a file translated using a particular hardware configuration will not meet all the requirements for an alternate set up. If this is the case, and a configuration error is reported by the Dynamic Test and the original .ASC file must either be edited until compatible or re-translated after a new configuration has been selected from the Configuration menu. Working in the DOS operating system, the .ASC file can be accessed with the case insensitive command: "EDIT [FileName].ASC". The field values can now be edited to best match the current operating hardware configuration. For example, if a file had been translated under a standard HP 11759C, and it was to be used with an 11759C OPT. 001, OPT H07 (Long Delay) instrument, the field name "FIFO DEPTH:" could be edited to change the default depth from 4096 to 32768. The Long Delay options contain 32k deep path delay FIFO's instead of the 4k FIFO's found in the standard units. Then, provided that the proper hardware is used, delay values of greater than 186 μ seconds could be sent from a data file to be output during a simulation.

Note



The .DAT file can also be viewed and edited using the DOS edit command. The file format will be very similar to that of the .ASC file, however the DATA section will have been converted to binary. However, text editors have been known to drop bits, losing some of the binary data when the file is re-stored. If this were to occur, simulation data would be lost or changed as well.

A complete description of the .DAT file format and acceptable commands is given in Appendix E.

One way to determine a simulation's acceptable configuration characteristics and void of errors is to view the hardware configuration file. To do this:

1. Enter the CHANSIM configuration menu.
2. The following is always true: UNIT #1 is always associated with paths one through six. The Simulator UNIT #2 is associated with paths seven through 12, if a second Simulator is configured.
3. Move to the configuration menu "Model" entry for the box which has the path whose configuration file name is desired. Take note

of the model number displayed, and then press ENTER to see a list of all the model number configuration files.

4. Find the previously remembered model number under the Description column of the hardware configuration file choice menu. Take note of the filename for that model number, which appears in the first column.
5. Exit the Configuration menu by pressing the ESCAPE key repeatedly (even to the yes/no questions) and get back to the main CHANSIM menu. Then press "Q" to quit and return to DOS.
6. Type the following to see the hardware configuration files:
"MORE < HwConfigFileName" where the actual file name is typed in place of "HwConfigFileName". For example, if the hardware config file name was HW0001.CFG, you would type "MORE < HW0001.CFG".

Press SpaceBar to page through the file. Press Ctl-C to stop viewing the file at any time.

A complete description of the field names and their usage for the hardware configuration files are given in Appendix F.

Dynamic Test Simulation

To run a translated .DAT file, the user must return to the Simulation software main menu and select the Dynamic Test option by pressing "D". At this point, a second menu is displayed, listing the functions available for setting up and executing a Dynamic Test. They are:

- R: Run Simulation From File
- H: Help
- Q: Quit

From there, selecting the "R: Run Simulation From File" option will produce a file browser list of the translated .DAT files available for selection. The files are listed by file name, with the file type (typically GENERAL or TRAVEL), Speed in kmh (if the simulation includes a moving reflector or receiver), and any title that may have been added. Use the arrow keys to scroll through the listing, and then press ENTER to select a file.

Note



In the playback of a Dynamic Test file, a user may recall up to 80 individual files. After 80 files, the additional files created do not appear on the file browser menu for selection; a file would have to be removed in order for a new one to be made available for simulation.

Once a file has been chosen, the Dynamic Test is executed, downloading the frame settings to the hardware to produce the desired simulation.

Note



The list of translated .DAT files available for simulation using the Dynamic Test includes both user-created files and Travel Test generated files. Either file type can be run using the Dynamic Test.

The Simulator will download the data file, resets the hardware to a known state, and then begins signal simulation for each path set up in the data file. During the time between the system reset and the processing of the .DAT data by the simulator, the instrument set-up has the following characteristics: Each path declared in the data file for use during the simulation will be turned on in it's defined spectral mode and set to either 0 Hz or 0 degrees and a delay of 0 μ seconds. The attenuation for each path is set to the maximum level of 50 dB. This is done to minimize the contribution of a path until it is used and directly assigned a different value. Any OFF path is disabled by a stopping of the delay FIFO clock for that path. When the simulation begins, the computer will update and display the simulation values as the data is clocked within the hardware to each Path Assembly, updating the output at the specified frame update rate.

DATA SHOWN IN SCREEN FOR EXAMPLE ONLY

HP11759(C/D) Channel Simulator Rev 3.26 DYNAMIC TEST
 Copyright (c) Hewlett-Packard Co. 1993

Sample file for dynamic test

| PATH | | DELAY | | ATTEN | DOPPLER or PHASE | |
|------|-----------|-------|---------|-------|------------------|-------|
| Num | Path type | Type | μ s | | Hz | Deg |
| #1 | DOPPLER | CLOCK | 10.0 | 5.0 | -20.0 | |
| #2 | DOPPLER | CLOCK | 11.0 | 6.0 | -20.0 | |
| #3 | OFF | | | | | |
| #4 | OFF | | | | | |
| #5 | PHASE | HIRES | 14.000 | 13.0 | | 128.2 |

FILE: SAMPLE.DAT | Update Rate: 10Hz | Download Complete %

[ESC] Quit, return to DYNAMIC TEST MAIN MENU.

Note



Resolution of values on the display has been designed to accommodate the available range setting resolutions (i.e.: 0.1 dB for attenuation, 1 nsecond for delay, etc.).

- **PATH** - Both the number of each path and its defined type (Doppler, Phase or OFF) is displayed for each path used in the simulation.

- DELAY - The delay type (DEPTH - Low resolution, HIRES - High resolution resolution or CLOCK - clock mode) and the amount of delay (in μ seconds) assigned to each path is displayed. The time value is updated as the simulation progresses.ency (in Hz) or phase (in degrees) is displayed.
- ATTENUATION - The current total signal attenuation (in dB) of each path is displayed.
- DOPPLER or PHASE - Depending upon the path type assigned to each path, the current frequency (in Hz) or phase (in degrees) is displayed.

Note

The data displayed on the update screen represents a sampling of the values occurring in time every (1/Update rate) seconds. For example, an update rate of 10 Hz, would result in a display of the simulation control values which are in effect at the end of every 0.10 second time interval.

The "Download Complete" percentage in the lower right-hand corner displays the amount of file data currently downloaded to the Simulator hardware. This number is not the current status of the signal output; when the download level reaches 100%, the simulation will continue at the .DAT specified update rate until the Simulator's internal data buffer is emptied.

Note

If a Travel Test data file is selected and run using the Dynamic Test, the Travel Test status display will be used to show the progression of the downloaded data. (See the Travel Test section of this manual for more information).

Update Rate

The rate at which the Dynamic Test updates the hardware can range from 1 Hz to 2.3 kHz. The maximum sustainable update rate is influenced by trade-offs in the allowable update rate, the number of paths or settings per path included in each frame, and the storage location of the data file. In addition to the delay FIFO's for each path, there is a FIFO on the Clock Synchronizer board (A7/A8) which buffers data from the PC Centronics cable to each of the Path Assemblies (A1-A6). The input control data and hardware settings are time released at the update rate. This Synchronizer (Sync) FIFO is only 2kbytes deep, and is initially loaded or "primed" to a level of about 1kbyte before any data is released for processing. This initial download of dummy data is done quickly, and once the Sync FIFO is primed, data is sent from the PC through the FIFO to the hardware for real time simulation. As setting data moves from the FIFO into the Path Assembly, additional data is continually supplied from the PC to maintain the 1kbyte buffer's depth, thereby maintaining real time operation at the specified update rate. If the initial 1kbyte of data consists of only a few frames of many individual

data specifications, as these frames are clocked to the hardware the FIFO could empty. At this point, the software would have to re-fill the FIFO to the operational 1kbyte buffer level. While the FIFO is empty, the internal delay boards are not receiving any hardware settings at the specified update rate, which momentarily interrupts the real time simulation. This characteristic imposes limitations on the possible simulation real time update rates. For data files containing a great number of elaborately defined frames, or lots of changes per frame, the maximum possible update rate may be limited. This problem can be minimized by reducing the number of hardware factors that change in any one frame.

For example, if all the parameter settings for all the system paths are to be varied over time, it can be done by either changing the value of each incrementally over a large number of frames or by using only a few frames and changing as many as possible, all at once. The first method can be played back at faster update rates than the second, where a majority of the FIFO memory has been used to store the settings for just one or two frames.

Note

If the Dynamic Test is being run remotely, entering the command: "SYST:ERR?" at the conclusion of the simulation allows the user to check the system for non-real time operation. This should not be done during a simulation however, because execution of the command itself will cause the systems to stop processing in real time. The command will return an error if the update rate specified was not simulated in real time. This is one way the user can develop and evaluate simulations optimizing the data files amongst the trade-offs that exist. In addition, the computer display will post a message immediately after the non-real time condition is detected.

Depending upon the storage medium specified in the Simulator software configuration file, the computer downloads the data file settings from either the computer hard drive or ram, and then updates the hardware at the user-specified update rate. Using the Configuration option from the Simulation software main menu, the user can arrange to download from the RAM disk by re-defining the locations of the system's Hard Drive Data Directory and the Fast Drive Data Directory. The Hard Drive Data Directory is where the 11759 simulation data files are stored. These files include the Travel Test and Dynamic Test .DAT files as well as Rayleigh and I/Q data files.

This directory can be changed to access files over a LAN or another directory separate from where the Simulation software is stored.

Note

Because computer LAN software is like a hard drive, subject to occasional interrupt servicing pauses or system calibrations, it too may not be able to provide real time simulation rates.

The factory default setting for this directory is C:\CHANSIM. This is the same as the default installation directory. The Fast Drive Data Directory is where the simulation data file is read from at real time rates while running a simulation. Because the simulations are to be run in real time, a fast drive is required: a 3200 kbyte or larger ram disk is recommended. The factory default setting is D:\. For simulations with update rates of less than 10 Hz, the PC's hard drive can be assigned as the Fast Drive Data Directory. At such slow rates, the periodic disk calibrations that can occur, and the slower access time of the hard drive will not typically inhibit performance. However, for rates of greater than 10 Hz, it is recommended to set the Fast Drive Data Directory to a ram disk. To do this, the .DAT file must then be manually loaded onto the RAM drive using the following steps:

1. Translate the original .ASC file to a .DAT file.
2. Copy the file [FileName.DAT] to the RAM drive (D: is the default location).
3. Change the set-up entries in the configuration menu to reflect the re-assignment of the Fast Drive Data Directory to the RAM drive.
4. Run the Dynamic Test using the .DAT file to generate a simulation.

This way, the simulation data may be downloaded at a much faster update rate.

Additional Applications

A copy of the sample .DAT Dynamic Test file included in the Simulation software is provided in Appendix D. This file can be edited to generate short simulations at slower update rates that might be used as a means of exploring all the control options available using the Dynamic Test and to measure the results. By using a programming interface, ASCII file can be generated to simulate complex scenarios. Simulations like cellular radio transmission hand-off tests, channel hopping and models of data measured during field testing can all be generated in a repeatable and reliable manner.

3-10. IQMAKE

IQMAKE is a utility program that is used to create custom or default fading datafiles (also referred to as .IQ files and Rayleigh files) for use during Simulation testing. IQMAKE has numerous options, and various combinations of options can be used together to build custom fading datafiles. The output filename is in the format RAYX.IQ where X is the Doppler frequency x 10.

Each datafile set takes approximately 35-40 minutes to build using a 33 MHz/486 with a hard disk. 12 paths of Rayleigh data are always built and 64 K data points are built per path (unless changed using the -k option).

Each file will play for approximately 27 seconds then repeat.

The basic command format is as follows:

IQMAKE[-X] Dopp1 [Dopp2[Dopp3...]]

Where

[-X] is an option switch. The various options are explained below.

Dopp1 [Dopp2 [Dopp3 ...]] are the Doppler values used (maximum of 20 per command line) when building the datafiles. One data file is built for each value. The Doppler values can be specified in Hz, or in KMH if the -r option is set (see below).

Example iqmake 45.4 33.0 99.9

Builds Rayleigh data files for 45.4 Hz, 33.0 Hz and 99.9 Hz. Files are named RAY454.IQ, RAY330.IQ and RAY999.IQ in the current directory.

Example iqmake -- -83.4 67

Builds Rayleigh data files for -83.4 Hz and 67 Hz. Builds files named RAY-834.IQ and RAY670.IQ in the current directory. The "--" prevents the -83.4 from being interpreted as a command line option.

Example iqmake -r 900E6 50 100

Builds Rayleigh data files for 50 KMH and 100 KMH at the RF frequency of 900 MHz. Files are named RAY417.IQ and RAY834.IQ (41.694462 Hz, and 83.388924 Hz) in the current directory.

All options are fully explained below, with examples. Type "IQMAKE-h" for a listing of the available options.

-b

BASENAME - sets the name use to generate file names. Default is RAY.

Example `iqmake -b TEST -r 100.5E6 16`

Builds Rayleigh data files for 16 KMH at the RF frequency of 100.5 MHz. File is named TEST15.IQ (1.489882 Hz) in the current directory. The -b replaces the default file base name RAY with TEST.

Example `iqmake -b C:\CHANSIM\RAY 55`

Builds a Rayleigh data file for 55 Hz named C:\CHANSIM\RAY550.IQ. The -b replaces the default file base name RAY with C:\CHANSIM\RAY. The .IQ file is built in the current directory. For example, this can be used to run more quickly by changing directory to a RAM disk and then running "C:\CHANSIM\IQMAKE -B C:\CHANSIM\RAY -D".

-d

DEFAULT - only the default Doppler values of 216:8 208:5 166:8 83.4 41.7 26.7 6.7 2.5 0.0 (in Hz) will be built.

-f

FILE READ - the filename specified after -f contains the ASCII I and Q data that is read from the file and output to the .IQ file. If the ASCII file has a .IQ file header, the header's values will override any command line parameters.

The -f option provides a way to supply user specified fading data to the Channel Simulation menu. "iqmake -F FileName DoppHz" converts DOS text files of ASCII numbers into formatted Rayleigh .IQ files. These files may then be read by the Channel Simulation menu to program the IQ modulators on up to 12 paths during the simulation. Information for the ASCII file is as follows:

- Each line of up to 12 path IQ integer pairs is converted to the .IQ output file and then read by the Channel Simulation menu & sent to the Simulator path IQ modulators at a nominal 2381 Hz rate. The modulators are low-pass band limited. Check the HP 11759 Operating Manual for details.
- Numbers will be rounded or clipped as necessary.
- The 1st two numbers are the I & Q values respectively for path 1. Next is path 2, etc. The user is allowed to put less than 12 IQ pairs per line. If there are less than 12 IQ pairs, the remaining pairs will be filled with IQ values in the following manner.
 - If there are 3, 5, 7, 9, 10, 11, or 13 through 23 numbers on the line the remaining path IQ values are set to zero.

- If there are 1, 2, 4, 6, 8, or 12 numbers on the line, those numbers are reused for that line's remaining path IQ values.
- To see an example file, cd to the chansim program directory and then type TYPE SAMPLEIQ.TXT (and press RETURN).

Example `iqmake -f sampleiq.txt 23.23`

Builds a Rayleigh data file for 23.23 Hz from the ASCII file sampleiq.txt. File is named RAY232.IQ in the current directory.

The example file sampleiq.txt included with the software has no .IQ file header, therefore, the Doppler frequency must be specified. The .IQ file header will be added automatically to RAY232.IQ. To see a .IQ file header, look at any .IQ file using the "more" < FileName" command.

Example `iqmake -f iqdata.new`

Builds a Rayleigh data file from the ASCII file iqdata.new. This command can only work if iqdata.new has a .IQ file header. If it does not, a "No frequency values were specified." error will occur because IQMAKE won't know which Doppler frequency to build. To see a .IQ file header, look at any .IQ file using the "more < FileName" command.

Note



To see a .IQ file header, look at any .IQ file using the "more < FileName" command. I and Q values must be between -2047 and 2047 inclusive. Blank lines and lines starting with # are ignored. If there are less than 12 paths of data on a line, the data will be expanded to 12 paths by replicating or zero filling depending on the number of paths on the line. Line length must be less than 180 characters.

-h

HELP - display examples and information on how to use this program.

-k

K POINTS - the number specified after -k defines how many 1024- points per path there are. Default is 64. -k numbers can only be 1, 2, 4, 8, 16, 32, or 64.

Example `iqmake -k 16 2.14`

*Builds a Rayleigh data file for 2.14 Hz. File is named RAY21.IQ in the current directory. 16 * 1024 data points are built per path.*

Example `iqmake -k 32 -t "Latest Auto Test" 45.04`

*Builds a Rayleigh data file for 45.04 Hz. File is named RAY450.IQ in the current directory. Puts a title in the .IQ file of "Latest Auto Test". 32 * 1024 points are built per path.*

-n

NO EXECUTION - displays what would happen, but does not perform the build function.

-o

OUTPUT RATE - currently not available. DO NOT USE.

-p

PATHS - currently not available. DO NOT USE.

-r

USE KMH - the number specified after -r is the RF frequency in Hz. The parameters after the RF frequency are velocity values in KMH.

Example iqmake -r 900E6 50 100

Builds Rayleigh data files for 50 KMH and 100 KMH at the RF frequency of 900 MHz. Files are named RAY417.IQ and RAY834.IQ (41.694462 Hz, and 83.388924 Hz) in the current directory.

-t

TITLE - enters the title. Default is "Standard Rayleigh spectrum." Quotes must surround the title if there are any spaces in the title. Maximum title length is 30 characters.

Example iqmake -k 32 -t "Latest Auto Test" 45.04

*Builds a Rayleigh data file for 45.04 Hz. File is named RAY450.IQ in the current directory. Puts a title in the .IQ file of "Latest Auto Test". 32 * 1024 points are built per path.*

-u

UNCONDITIONAL BUILD - without the -u option, an existing file will not be re-built (this is the default safety feature). However, if -u is used the file(s) will be built. Note that existing file(s) will be lost and cannot be recovered.

3-11. HP-IB Remote Operating Procedures

Procedures for executing Simulator System SCPI commands using a remote HP-IB controller connected to the Simulator's rear panel HP-IB connector are provided below. Refer to "Local Operating Procedures" in this chapter for instructions on performing actual tests. Remote control operating procedures using a terminal/computer's serial port are provided in paragraph 3-12.

The Simulator complies with the following IEEE STD 488.1-1987 compatibility codes: SH1, AH1, T5, TE0, L3, LE0, SR0, RL0, PP0, DC0, DT0, C0, and E2.

Note



Serial commands are accepted over HP-IB with the following limitations:

- "single-key commands" are not supported.
- OK or ?? is not returned after every command or at startup.
- commands to the Simulator are terminated with <LF> or <CR><LF> (not <CR>).
- query responses ended with <LF> (not <CR><LF>).

Command Types

HP-IB commands are separated into two types: IEEE 488.2 Common Commands and Standard Commands for Programmable Instruments (SCPI) Commands.

Common Command Format

The IEEE 488.2 standard defines the Common Commands that perform functions like reset, self-test, identification query, etc. Common commands are four or five characters in length, always begin with the asterisk character (*), and may include one or more parameters. The command keyword is separated from the first parameter by a space character. Some examples of Common Commands are shown below:

*RST *CLS *IDN?

SCPI Command Format

The SCPI commands perform functions like setting parameters, performing measurements, querying instrument states, and retrieving data. A subsystem command structure is a hierarchical structure that usually consists of a top level (or root) command, one or more lower level sub commands, and their parameters. The following example shows part of a typical subsystem:

```
SMODifier[<number>]
:DELay<value>
:RESolution LOW|HIGH
:RESolution?
```

SMODifier is the root command with *<number>* as part of the mnemonic, DELay is the second level sub command with *<value>* as a parameter, and :RESolution and :RESolution? are third level commands/queries with LOW|HIGH as a parameter.

Command Separator

A colon (:) always separates one command from the next lower level command as shown below:

```
SMODifier1:DELay:RESolution?
```

Colons separate the root command from the second level command (SMODifier1:DELay), and the second level from the third level query (DELay:RESolution?).

Abbreviated Commands

The command syntax shows most commands as a mix of upper and lower case letters. The upper case letters indicate the abbreviated spelling for the command. For shorter program lines, send only the abbreviated form. For better program readability, you may send the entire command. The instrument will only accept either the abbreviated form or the entire command.

For example, if the command syntax shows RESolution?, then RES? and RESOLUTION? are both acceptable forms. Other forms of RESolution?, such as RE? will generate an error. You may use upper or lower case letters. Therefore, RESOLUTION? and RESoLuTiOn? are acceptable.

Implied Commands

Implied commands are those which appear in square brackets ([]) in the command syntax. (Note that the brackets are not part of the command and are not sent to the instrument.) Suppose you send a root level and second level command, but do not send the third level implied command. In this case, the instrument assumes you intend to use the implied command and it responds as if you had sent it. Examine the portion of the SMODifier subsystem shown below:

```
SMODifier[<number>]
:PHASe
[:ADJust]<value>
[:ADJust]?
```

The third level command [ADJust:] is an implied command. To query the instrument's path 1 phase selection, you can send either of the following command statements:

```
SMOD1:PHAS:ADJ? or SMOD1:PHAS?
```

Sending Remote Commands

The following guidelines must be observed when sending remote commands to the Channel Simulator using the HP-IB interface:

- The Vectra PC keyboard will not read keys during remote control of the channel simulator, except for Q, <esc>, and Cntl-C. If the remote control datacom connection fails, the "Q" and the <esc> keys on the Vectra PC keyboard will escape out of any test, and then exit the main program. This avoids having to reboot the PC in the event of difficulty.
- Each command must be followed by a <LF>, or it will not be recognized by the Channel Simulator. Command lines must be less than 80 characters.
- Word commands are always echoed on the bottom of the Vectra PC display as they are received. The remote messages may be monitored by watching this display line.
- The HP-IB error queue should be checked frequently to catch errors and avoid overwriting the Channel simulator buffer. Rayleigh nonrealtime and other errors are only reported once via the error queue.
- The bus controller may query at any time to verify if nonrealtime operations have occurred since the last query. The ".IQ" outputs will momentarily stop to allow the status check and query via the Vectra PC.
- Each returned query message from the Vectra PC back to the remote controller is always terminated by a <LF> with EOI asserted.
- Any suffix after a numeric argument will generate an error. For example, the command "SMOD1:DELAY 55 ms" will return "ERROR: Needs a numeric argument".
- Only one command or query per line is allowed.
- For queries, the entire response must be read (within five seconds or else it must be re-addressed) from the Simulator, or the first character will be dropped from the next command.
- Wait at least one second after sending any command if the Vectra PC is currently running Rayleigh, to allow the HP-IB interface to reset. Also, wait 5 seconds after sending the following commands to allow the Simulator to execute program/menu loads:
 - PROGRAM:NAME
 - PROGRAM:STATe:STOP
 - SMODifier:SPECTrum:TYPE RAYLeigh

Parameters **Parameter Types.** The Table 3-1 contains explanations and examples of parameter types you might see later in this chapter.

Table 3-1. Parameter Types

| Parameter Type | Explanations and Examples |
|----------------|---|
| Numeric | Accepts all commonly used decimal representations of numbers including optional signs, decimal points, and scientific notation. 123 or 1.23E2; -123 or -1.23E2; .123, 1.23E-1, or 1.23000E-01. |
| Discrete | Selects from a finite number of values. These parameters use mnemonics to represent each valid setting. An example is the PROGram:STATe <state> command where <state> is STOP. |

PROGram

The PROGram command subsystem is used to run and terminate the Simulation (or Ghost), Travel, and Dynamic tests. Refer to the Local Operation, Simulation Test presented earlier in this chapter for more information on tests.

Subsystem Syntax

```
PROGram
  :NAME <program_name>
  :NAME?
  :STATe <state>
```

:NAME

PROGram:NAME <program_name> is used to configure the Simulator for a specific test.

Parameters

| Parameter Name | Parameter Type | Range of Values | Default Units |
|---------------------|----------------|--|---------------|
| <i>program_name</i> | discrete | MAIN SIMULATION GHOST DYNAMIC TRAVEL | MAIN |

Example Run the Travel Test

```
PROG:NAME TRAVEL Configure Simulator for a Travel Test
```

Comments

- **Selecting *program_name*.** Only one test can be specified at a time. After selecting a test, wait at least 5 seconds before executing another command to allow time for the test to be loaded and initiated. If the identical *program_name* is specified for a test that is already running, the command is ignored. A test must be terminated (using PROGram:STATe command) prior to selecting a different test.
- **Selecting GHOST.** Selecting GHOST is the same as selecting SIMULATION.
- **Related Commands:** PROGram:NAME?, PROGram:STATe.

:NAME?

PROG:NAME? returns the test currently running. Refer to the **PROG:NAME** command for more information on the tests available.

Example

Read the current test

dimension statement *Dimension a string*
PROG:NAME? *Query instrument to return the current test*

Comments

- **Related Commands:** **PROG:NAME**.

:STATE

PROG:STATE <state> is used to terminate any test currently running.

Parameters

| Parameter Name | Parameter Type | Range of Values | Default Units |
|----------------|----------------|-----------------|---------------|
| <i>state</i> | discrete | STOP | none |

Example

Stop the current test

PROG:STAT STOP *Terminate a running test*

Comments

- **Selecting state.** If any test (other than MAIN) is running when state is selected, the test is terminated and MAIN is executed. If MAIN is running when state is selected, the channel simulation software is exited (to the DOS prompt). Wait at least 5 seconds after stopping a test before executing another command.
- **Related Commands:** **PROG:NAME**.

MMEMemory

The MMEMemory command subsystem is used to list, store, and load standard and user defined profiles. Refer to the Local Operation, Simulation Test presented earlier in this chapter for more information on profiles.

Subsystem Syntax

```

MMEMemory
  :CATalog?
  :LOAD
    :STATE <state_number> ,<state_type>
    :TRACe <filename>
  :STORe
    :STATE <state_number> ,<state_title>

```

:CATalog?

MMEMemory:CATalog? returns a catalog of standard and user profiles. Refer to the Local Operation, Simulation Test presented earlier in this chapter for more information on profiles.

Example

Read the profile catalog

```

dimension statement  Dimension a string
MME:CAT?            Query instrument to return the profile
                    catalog

```

Comments

- **Program Type:** This command is implemented when the simulation test is selected. See PROGRAM:NAME SIMULATION (or GHOST) for more information.
- **Returned Format:** The catalog results are returned in the following format (20 groups separated by a comma):
 <state_number>,<state_title>,<state_type>,.
 Where:
 state_number is the register number or profile number.
 state_title is the title or name of the profile.
 state_type returns USER or STANDARD indicating the register type. USER indicates user-defined profiles, and STANDARD indicates pre-defined profiles.
- **Related Commands:** PROGRAM:NAME, MMEMemory:LOAD:STATE, MMEMemory:STORe:STATE.

:LOAD:STATE

MMEMory:LOAD:STATE<state_number>,<state_type> is used to load a specific profile. Refer to the Local Operation, Simulation Test presented earlier in this chapter for more information on profiles.

Parameters

| Parameter Name | Parameter Type | Range of Values | Default Units |
|---------------------|----------------|-----------------|---------------|
| <i>state_number</i> | numeric | 1 to 10 | 1 |
| <i>state_type</i> | discrete | USER STANDARD | |

Example Load user profile number 4

MMEM:LOAD:STAT 4,USER *Load user profile number 4*

Comments

- **Program Type:** This command is implemented when the simulation test is selected. See PROGRAM:NAME SIMULATION (or GHOST) for more information.
- **Selecting state_number.** The profile numbers available can be returned using the MMEMory:CATalog? query. If a number is selected out of the legal range, an error is returned.
- **RAYleigh Files:** Before a specific profile containing RAYleigh files is to be selected, a pre-configured RAYleigh fading data file must first be selected using the SMODifer:RAYleigh:FILENAME command.
- ***RCL.** Selecting MMEM:LOAD:STAT <state_number>,USER is identical to sending *RCL <state_number>.
- **Related Commands:** *RCL, PROGRAM:NAME, MMEMory:CATalog?.
- If the STANdard profile has RAYleigh spectrum chosen for any path (this is true for all STANdard profiles provided by the factory), a file must have been chosen by SMOD [<path>]:RAYleigh:FILENAME. If not, an error will occur and the profile will not be loaded.

:LOAD:TRACe

MMEMory:LOAD:TRACe <filename> is used to load and run a specific ".DAT" file that contains the setup and previously recorded simulation data for use during Travel or Dynamic Test. Refer to the Local Operation, Travel/Dynamic Test presented earlier in this chapter for more information on profiles.

Parameters

| Parameter Name | Parameter Type | Range of Values | Default Units |
|-----------------|----------------|---|---------------|
| <i>filename</i> | string | 11 character alphanumeric string (normally with .DAT extension) | |

Example Load TRV1.DAT for Travel/Dynamic Test

MMEM:LOAD:TRAC "TRV1.DAT" *Load file TRV1.DAT for travel or dynamic test*

Comments

- **Program Type:** This command is implemented when the travel or dynamic test is selected. See PROGRAM:NAME TRAVEL (or DYNAMIC) for more information.
- **Entering name:** The name can be any 11 character alphanumeric string, including special characters (typically .DAT). If the filename cannot be found, an error is generated.
- **Related Commands:** PROGRAM:NAME, MMEMory:CATalog?.

Note

File can only be stopped by sending a single ESC character (ASCII 28) over the HP-IB bus.

:STORE:STATE

MMEMory:STORe:STATe<state_number>,<state_title> is used to store the current configuration as a user-defined profile. Refer to the Local Operation, Simulation Test presented earlier in this chapter for more information on profiles.

Parameters

| Parameter Name | Parameter Type | Range of Values | Default Units |
|----------------|----------------|----------------------------------|---------------|
| state_number | numeric | 1 to 10 | 1 |
| state_title | string | 55 character alphanumeric string | |

Example Store current configuration as user profile 9

MMEM:STOR:STAT 9,"GSM/PCN RAX RURAL AREA" *Store current configuration as user profile number 9, with "GSM/PCN RAX RURAL AREA" as the title*

Comments

- **Program Type:** This command is implemented when the simulation test is selected. See PROGRAM:NAME SIMULATION (or GHOST) for more information.
- **Selecting state_number.** The profile numbers currently used can be returned using the MMEMory:CATalog? query. If a number is selected out of the legal range, an error is returned. If a profile is currently stored at the state_number given, the previous data will be overwritten (cannot be recovered).
- **Entering state_title.** The state_title can be any continuous 55 (or less) character alphanumeric string, including special characters.
- ***SAV.** Selecting MMEM:STOR:STAT <state_number>,"" is identical to sending *SAV <state_number>.
- **Related Commands.** *SAV, PROGRAM:NAME, MMEMory:CATalog?.

SMODifier

The SMODifier command subsystem is used to display and/or change simulation test parameters for the individual paths. Refer to the Local Operation, Simulation Test presented earlier in this chapter for more information on parameters.

Subsystem Syntax

```
SMODifier[<path>]
:ATTenuation<atten>
:ATTenuation?
:DELAy<time>
:RESolution<resol>
:RESolution?
:DELAy?
:DOPPLer
:FREQuency<frequency>
:FREQuency?
:LO
:FREQuency<frequency>
:FREQuency?
:RF
:FREQuency<frequency>
:FREQuency?
:PHASe
[:ADJust]<phase>
[:ADJust]?
:CORRelation<corre>
MODE<mode>
MODE?
:CORRelation?
:RAYLeigh
:FILEName<name>
:FILEName?
:SPECTrum
[:TYPE]<type>
[:TYPE]?
```

Note



Root level commands PATH or RAY may be substituted for SMODifier.

:ATTenuation

SMODifier[<path>]:ATTenuation<atten> is used to set the attenuation level applied to the path number specified. Refer to the Local Operation, Simulation Test presented earlier in this chapter for more information on attenuation.

Parameters

| Parameter Name | Parameter Type | Range of Values | Default Units |
|----------------|----------------|-------------------|---------------|
| <i>path</i> | numeric | 1 to 6 or 1 to 12 | 1 |
| <i>atten</i> | numeric | 0 dB to 50 dB | 0.0 dB |

Example Set path number 4 attenuation to 1.1 dB

SMOD4:ATT 1.1 *Set attenuation on path #4 to 1.1 dB*

Comments

- **Program Type:** This command is implemented when the simulation test is selected. See PROGRAM:NAME SIMULATION (or GHOST) for more information.
- **Selecting Path Number:** Any path from 1 to 6 or 1 to 12 can be selected. If path number is not specified, path #1 is used. If the path is not available (dependent on the Simulator's option/model number), an error is generated.
- **Entering <atten>:** Any level from 0.0 to 50.0 dB in 0.1 dB steps can be entered. Attenuation entered is relative to the other paths (normally path #1). Values entered that are out of range will generate an error.
- **Related Commands:** PROGRAM:NAME, SMODifier:ATTenuation?.

:ATTenuation?

SMODifier[<path>]:ATTenuation? returns the current attenuation level for the path number specified. Refer to the Local Operation, Simulation Test presented earlier in this chapter for more information on attenuation.

Parameters

| Parameter Name | Parameter Type | Range of Values | Default Units |
|----------------|----------------|-------------------|---------------|
| <i>path</i> | numeric | 1 to 6 or 1 to 12 | 1 |

Example Read attenuation for path number 4

```
dimension statement Dimension a string
SMOD4:ATT?         Query instrument to return the path
                    #4 attenuation
```

Comments

- **Program Type:** This command is implemented when the simulation test is selected. See PROGRAM:NAME SIMULATION (or GHOST) for more information.
- **Selecting Path Number:** Any path from 1 to 6 or 1 to 12 can be selected. If path number is not specified, path #1 is used. If the path is not available (dependent on the Simulator's option/model number), an error is generated.
- **Returned Format:** The attenuation results are returned as XX.X dB.
- **Related Commands:** PROGRAM:NAME, SMODifier:ATTenuation.

:DElay

SMODifier[<path>]:DElay <time> is used to set the amount of delay applied to the path number specified. Refer to the Local Operation, Simulation Test presented earlier in this chapter for more information on delay.

Parameters

| Parameter Name | Parameter Type | Range of Values | Default Units |
|----------------|----------------|-----------------------------|---------------|
| <i>path</i> | numeric | 1 to 6 or 1 to 12 | 1 |
| <i>time</i> | numeric | -0.00018618 to 0.00018618 s | 0.0 s |

Example Set path number 4 delay to 50 μ s

```
dimension statement Dimension a string
SMOD4:DEL 50E-6      Set delay on path #4 to 50  $\mu$ s
```

Comments

- **Program Type:** This command is implemented when the simulation test is selected. See PROGRAM:NAME SIMULATION (or GHOST) for more information.
- **Selecting Path Number:** Any path from 1 to 6 or 1 to 12 can be selected. If path number is not specified, path #1 is used. If the path is not available (dependent on the Simulator's option/model number), an error is generated.
- **Entering<time>:** Any level from -186.18 μ s to +186.18 μ s can be entered. Values entered that are out of range will generate an error.
- **Delay Resolution:** Resolution (for the Simulator) can be selected using the SMODifier:DElay:RESolution command.
- **Related Commands:** PROGRAM:NAME, SMODifier:DElay:RESolution, SMODifier:DElay?.

:DElay:RESolution

SMODifier[<path>]:DElay:RESolution<resol> is used to set the delay resolution to HIGH (1ns) or LOW (50ns) for the simulator system. Refer to the Local Operation, Simulation Test presented earlier in this chapter for more information on delay resolution.

Parameters

| Parameter Name | Parameter Type | Range of Values | Default Units |
|----------------|----------------|-------------------|---------------|
| <i>path</i> | numeric | 1 to 6 or 1 to 12 | 1 |
| <i>resol</i> | discrete | HIGH LOW | LOW |

Example Set path number 4 delay resolution to 1 ns

SMOD4:DEL:RES HIGH *Set delay resolution on path #4 to 1ns*

Comments

- **Program Type:** This command is implemented when the simulation test is selected. See PROGRAM:NAME SIMULATION (or GHOST) for more information.
- **Selecting Path Number:** Any path from 1 to 6 or 1 to 12 can be selected. If path number is not specified, path #1 is used. If the path is not available (dependent on the Simulator's option/model number), an error is generated. Selecting any one path changes the resolution for all the other paths.
- **Delay:** Delay for each path is entered using the SMODifier:DElay command.
- **Related Commands:** PROGRAM:NAME, SMODifier:DElay, SMODifier:DElay:RESolution?.

DElay:RESolution?

SMODifier[<path>]:DElay:RESolution? returns the current delay resolution (HIGH or LOW) for the simulator system. Refer to the Local Operation, Simulation Test presented earlier in this chapter for more information on delay resolution.

Parameters

| Parameter Name | Parameter Type | Range of Values | Default Units |
|----------------|----------------|-------------------|---------------|
| <i>path</i> | numeric | 1 to 6 or 1 to 12 | 1 |

Example

Read delay resolution for path number 4

dimension statement *Dimension a string*
 SMOD4:DEL:RES? *Query instrument to return the path #4 delay resolution*

Comments

- **Program Type:** This command is implemented when the simulation test is selected. See PROGRAM:NAME SIMULATION (or GHOST) for more information.
- **Selecting Path Number:** Any path from 1 to 6 or 1 to 12 can be selected. If path number is not specified, path #1 is used. If the path is not available (dependent on the Simulator's option/model number), an error is generated.
- **Returned Format:** The delay resolution results are returned as HIGH (1 ns resolution) or LOW (50 ns resolution).
- **Related Commands:** PROGRAM:NAME, SMODifier:DElay, SMODifier:DElay:RESolution.

:DElay?

SMODifier[<path>]:DElay? returns the current amount of delay for the path number specified. Refer to the Local Operation, Simulation Test presented earlier in this chapter for more information on delay.

Parameters

| Parameter Name | Parameter Type | Range of Values | Default Units |
|----------------|----------------|-------------------|---------------|
| <i>path</i> | numeric | 1 to 6 or 1 to 12 | 1 |

Example Read delay for path number 4

```

dimension statement  Dimension a string
SMOD4:DEL?         Query instrument to return the path
                    #4 delay

```

Comments

- **Program Type:** This command is implemented when the simulation test is selected. See PROGRAM:NAME SIMULATION (or GHOST) for more information.
- **Selecting Path Number:** Any path from 1 to 6 or 1 to 12 can be selected. If path number is not specified, path #1 is used. If the path is not available (dependent on the Simulator's option/model number), an error is generated.
- **Returned Format:** The delay results are returned as plus or minus seconds ($\pm X.XXXXXX E-XX$ seconds) where blank indicates positive.
- **Related Commands:** PROGRAM:NAME, SMODifier:DElay, SMODifier:DElay:RESolution.

:DOPPLer:FREQUency

SMODifier[<path>]:DOPPLer:FREQUency<frequency> is used to set the Doppler frequency shift applied to the path number specified. Refer to the Local Operation, Simulation Test presented earlier in this chapter for more information on Doppler.

Parameters

| Parameter Name | Parameter Type | Range of Values | Default Units |
|------------------|----------------|----------------------|---------------|
| <i>path</i> | numeric | 1 to 6 to 1 to 12 | 1 |
| <i>frequency</i> | numeric | -425.0Hz to +425.0Hz | 0.0 Hz |

Example

Set path number 4 Doppler frequency shift to 10Hz

SMOD4:DOPP:FREQ 10.0 *Set Doppler shift on path #4 to 10.0 Hz*

Comments

- **Program Type:** This command is implemented when the simulation test is selected. See PROGRAM:NAME SIMULATION (or GHOST) for more information.
- **Spectrum Type:** This command is implemented when SMODifier:SPECTrum is set to DOPPLer. If executed with SMODifier:SPECTrum set to RAYleigh, an error is generated. This command has no effect when SMODifier:SPECTrum is set to OFF or PHASe.
- **Selecting Path Number:** Any path from 1 to 6 or 1 to 12 can be selected. If path number is not specified, path #1 is used. If the path is not available (dependent on the Simulator's option/model number), an error is generated.
- **Actual Doppler Shift:** Total Doppler shift is dependent on the path RF frequency set using the SMODifier:RF:FREQUency command.
- **Entering<frequency>:** Any frequency from -425.0 Hz to +425.0 Hz in 0.001 Hz steps can be entered. Values entered that are out of range will generate an error.
- **Related Commands:** PROGRAM:NAME, SMODifier:DOPPLer:FREQUency?.

:DOPPler:FREQUency? SMODifier[<path>]:DOPPler:FREQUency? returns the current Doppler frequency for the path number specified. Refer to the Local Operation, Simulation Test presented earlier in this chapter for more information on Doppler.

Parameters

| Parameter Name | Parameter Type | Range of Values | Default Units |
|----------------|----------------|-------------------|---------------|
| <i>path</i> | numeric | 1 to 6 or 1 to 12 | 1 |

Example Read Doppler frequency for channel 2

```
dimension statement Dimension a string
SMOD4:DOPP:FREQ?   Query instrument to return the path
                    #4 Doppler shift
```

Comments

- **Program Type:** This command is implemented when the simulation test is selected. See PROGRAM:NAME SIMULATION (or GHOST) for more information.
- **Selecting Path Number:** Any path from 1 to 6 or 1 to 12 can be selected. If path number is not specified, path #1 is used. If the path is not available (dependent on the Simulator's option/model number), an error is generated.
- **Returned Format:** The Doppler frequency results are returned as \pm XXX.XXX Hz (blank indicates positive).
- **Related Commands:** PROGRAM:NAME, SMODifier:DOPPler:FREQUency.

:LO:FREQuency

SMODifier[<path>]:LO:FREQuency<frequency> is used to set the local oscillator frequency for the path number specified. Refer to the Local Operation, Simulation Test presented earlier in this chapter for more information on local oscillator frequency.

Parameters

| Parameter Name | Parameter Type | Range of Values | Default Units |
|------------------|----------------|----------------------------------|---------------|
| <i>path</i> | numeric | 1 to 6 or 1 to 12 | 1 |
| <i>frequency</i> | numeric | 40 000 000 Hz to 2 700 000 000Hz | 894 MHz |

Example Set channel 2 local oscillator frequency to 800MHz

SMOD4:LO:FREQ 800E6 *Set L.O. frequency for paths 4-6 to 800 MHz*

Comments

- **Program Type:** This command is implemented when the simulation tset is selected. See PROGRAM:NAME SIMULATION (or GHOST) for more information.
- **Selecting Path (Channel) Number:** Any path from 1 to 6 or 1 to 12 can be selected. Selecting any path in a channel sets local oscillator frequency for the entire channel. If path number is not specified, path #1 is used. If the path is not available (dependent on the Simulator's option/model number), an error is generated.
- **Entering<frequency>:** Any frequency from 40.0 Hz to 2700.0 MHz in 0.1 Hz steps can be entered. Values entered that are out of range will generate an error.
- **Related Commands:** PROGRAM:NAME, SMODifier:LO:FREQuency?, SMODifier:RF:FREQuency.

:LO:FREQuency?

SMODifier[<path>]:LO:FREQuency? returns the current local oscillator frequency for the path number specified. Refer to the Local Operation, Simulation Test presented earlier in this chapter for more information on local oscillator frequency.

Parameters

| Parameter Name | Parameter Type | Range of Values | Default Units |
|----------------|----------------|-------------------|---------------|
| <i>path</i> | numeric | 1 to 6 or 1 to 12 | 1 |

Example Read local oscillator frequency for channel 2

```
dimension statement Dimension a string
SMOD4:LO:FREQ? Query instrument to return the chan-
                nel 2 L.O. frequency
```

Comments

- **Program Type:** This command is implemented when the simulation test is selected. See PROGRAM:NAME SIMULATION (or GHOST) for more information.
- **Selecting Path (Channel) Number:** Any path from 1 to 6 or 1 to 12 can be selected. Selecting any path in a channel sets local oscillator frequency for the entire channel. If path number is not specified, path #1 is used. If the path is not available (dependent on the Simulator's option/model number), an error is generated.
- **Returned Format:** The local oscillator frequency results are returned as \pm XXXXXX.X Hz (blank indicates positive).
- **Related Commands:** PROGRAM:NAME, SMODifier:LO:FREQuency, SMODifier:RF:FREQuency.

:RF:FREQUENCY

SMODifier[<path>]:RF:FREQUENCY<frequency> is used to set the RF frequency for the path number specified. Refer to the Local Operation, Simulation Test presented earlier in this chapter for more information on RF frequency.

Parameters

| Parameter Name | Parameter Type | Range of Values | Default Units |
|------------------|----------------|----------------------------------|---------------|
| <i>path</i> | numeric | 1 to 6 or 1 to 12 | 1 |
| <i>frequency</i> | numeric | 40 000 000 Hz to 2 700 000 000Hz | 900 MHz |

Example Set channel 2 RF frequency to 800MHz

SMOD4:RF:FREQ 800E6 *Set RF frequency for paths 4-6 to 800 MHz*

Comments

- **Program Type:** This command is implemented when the simulation test is selected. See PROGRAM:NAME SIMULATION (or GHOST) for more information.
- **Selecting Path (Channel) Number:** Any path from 1 to 6 or 1 to 12 can be selected. Selecting any path in a channel sets the RF frequency for the entire channel. If path number is not specified, path #1 is used. If the path is not available (dependent on the Simulator's option/model number), an error is generated.
- **Entering<frequency>:** Any frequency from 40.0 MHz to 2700.0 MHz in 0.1 Hz steps can be entered. Values entered that are out of range will generate an error.
- **Related Commands:** PROGRAM:NAME, SMODifier:RF:FREQUENCY?, SMODifier:LO:FREQUENCY.

:RF:FREQuency?

SMODifier[<path>]:RF:FREQuency? returns the current RF frequency for the path number specified. Refer to the Local Operation, Simulation Test presented earlier in this chapter for more information on RF frequency.

Parameters

| Parameter Name | Parameter Type | Range of Values | Default Units |
|----------------|----------------|-------------------|---------------|
| <i>path</i> | numeric | 1 to 6 or 1 to 12 | 1 |

Example Read RF frequency for channel 2

```
dimension statement  Dimension a string
SMOD4:RF:FREQ?      Query instrument to return the chan-
                     nel 2 RF frequency
```

Comments

- **Program Type:** This command is implemented when the simulation test is selected. See PROGRAM:NAME SIMULATION (or GHOST) for more information.
- **Selecting Path (Channel) Number:** Any path from 1 to 6 or 1 to 12 can be selected. Selecting any path in a channel sets the RF frequency for the entire channel. If path number is not specified, path #1 is used. If the path is not available (dependent on the Simulator's option/model number), an error is generated.
- **Returned Format:** The RF frequency results are returned as \pm XXXXXX.X Hz (blank indicates positive).
- **Related Commands:** PROGRAM:NAME, SMODifier:RF:FREQuency.

:PHASe[:ADJust]

SMODifier[<path>]:PHASe[:ADJust]<phase> is used to set the phase shift angle applied to the path number specified. Refer to the Local Operation, Simulation Test presented earlier in this chapter for more information on phase shift.

Parameters

| Parameter Name | Parameter Type | Range of Values | Default Units |
|----------------|----------------|--------------------------|---------------|
| <i>path</i> | numeric | 1 to 6 or 1 to 12 | 1 |
| <i>phase</i> | numeric | -360.0 deg to +360.0 deg | 0.0 deg |

Example

Set path number 4 phase shift to 10 degrees

```
SMOD4:PHAS 10.0 Set phase shift on path #4 to 10.0 deg
```

Comments

- **Program Type:** This command is implemented when the simulation test is selected. See PROGRAM:NAME SIMULATION (or GHOST) for more information.
- **SPECTrum Type:** This command sets the value in all modes, but only affects operation when the SMODifier:SPECTrum is set to PHASe.
- **Selecting Path Number:** Any path from 1 to 6 or 1 to 12 can be selected. If path number is not specified, path #1 is used. If the path is not available (dependent on the Simulator's option/model number), an error is generated.
- **Actual Phase Shift:** Total phase shift is dependent on the path RF Frequency set using the SMODifier:RF command.
- **Entering <phase>:** Any phase angle from -360.0 deg to +360.0 deg can be entered. Values entered that are out of range will generate an error.
- **Related Commands:** PROGRAM:NAME, SMODifier:PHASe?, SMODifier:RF:FREQuency.

:PHASe[:ADJust]?

SMODifier:[<path>]:PHASe[:ADJust]? returns the current phase shift angle for the path number specified. Refer to the Local Operation, Simulation Test presented earlier in this chapter for more information on phase shift.

Parameters

| Parameter Name | Parameter Type | Range of Values | Default Units |
|----------------|----------------|-------------------|---------------|
| <i>path</i> | numeric | 1 to 6 or 1 to 12 | 1 |

Example

Read phase shift for channel 2

```

dimension statement  Dimension a string
SMOD4:PHAS?        Query instrument to return the path
                    #4 phase shift
    
```

Comments

- **Program Type:** This command is implemented when the simulation test is selected. See PROGRAM:NAME SIMULATION (or GHOST) for more information.
- **Selecting Path Number:** Any path from 1 to 6 or 1 to 12 can be selected. If path number is not specified, path #1 is used. If the path is not available (dependent on the Simulator's option/model number), an error is generated.
- **Returned Format:** The phase shift results are returned as ±XXX.X deg.
- **Related Commands:** PROGRAM:NAME, SMODifier:PHASe, SMODifier:RF:FREQUency.

:CORRelation

SMODifier[<path>]:CORRelation<correl> is used to set the correlation factor for the path number specified. Refer to the Local Operation, Simulation Test presented earlier in this chapter for more information on correlation factor.

Parameters

| Parameter Name | Parameter Type | Range of Values | Default Units |
|----------------|----------------|-------------------|---------------|
| <i>path</i> | numeric | 1 to 6 or 1 to 12 | 1 |
| <i>correl</i> | numeric | 0.0 to 1.0 | 0.0 |

Example Set correlation factor for paths 1 and 4 to 0.5

SMOD:CORR 0.5 *Set correlation factor for paths 1 and 4 to 0.5*

Comments

- **Program Type:** This command is implemented when the simulation test is selected. See PROGRAM:NAME SIMULATION (or GHOST) for more information.
- **Spectrum Type:** This command is implemented only when the SMODifier:SPECTrum is set to RAYLeigh and SMODifier:CORRelation:MODE is set to 3X3 or 6X6.
- **Selecting Path Number:** Any path from 1 to 6 or 1 to 12 can be selected, however correlation factor is applied between various path pairs. See SMODifier:CORRelation:MODE for path configurations.
- **Entering<correl>:** Possible correlations are 0.0 to 1.0 in 0.1 steps. Values entered that are out of range will generate an error.
- **Related Commands:** PROGRAM:NAME, SMODifier:CORRelation?, SMODifier:CORRelation:MODE, SMODifier:SPECTrum.

:CORRelation:MODE

SMODifier[<path>]:CORRelation:MODE<mode> is used to enable and set the correlation factor path pair configuration for the simulator system. Refer to the Local Operation, Simulation Test presented earlier in this chapter for more information on correlation factor.

Parameters

| Parameter Name | Parameter Type | Range of Values | Default Units |
|----------------|----------------|-------------------|---------------|
| <i>path</i> | numeric | 1 to 6 or 1 to 12 | 1 |
| <i>mode</i> | discrete | NONE 3X3 6X6 | 0.0 |

Example

Set correlation factor mode to 3X3

```
SMOD:CORR:MODE 3X3 Set correlation factor mode to 3X3
```

Comments

- **Selecting Path:** Setting any one path's mode changes the correlation mode for all paths.
- **Program Type:** This command is implemented when the simulation test is selected. See PROGRAM:NAME SIMULATION (or GHOST) for more information.
- **SPECTrum Type:** This command is implemented only when the SMODifier:SPECTrum is set to RAYLeigh.
- **Selecting Mode:** Setting mode to NONE turns the correlation factor function to off. Setting 3X3 defines path pairs as 1/4, 2/5, 3/6, 7/10, 8/11, and 9/12. Selecting one path sets the correlation factor between both paths. Setting 6X6 (available only in dual Simulator arrangements) defines path pairs as 1/7, 2/8, 3/9, 4/10, 5/11, and 6/12. Selecting one path sets the correlation factor between both paths. If the path is not available (dependent on the Simulator's option/model number), an error is generated. Changing correlation mode sets correlation factor for all paths to 0.
- **Related Commands:** PROGRAM:NAME, SMODifier:CORRelation, SMODifier:CORRelation:MODE?, SMODifier:SPECTrum.

:CORRelation:MODE?

SMODifier[<path>]:CORRelation:MODE? returns the current correlation factor mode for the simulator system. Refer to the Local Operation, Simulation Test presented earlier in this chapter for more information on correlation factor.

Parameters

| Parameter Name | Parameter Type | Range of Values | Default Units |
|----------------|----------------|-------------------|---------------|
| <i>path</i> | numeric | 1 to 6 or 1 to 12 | 1 |

Example Read correlation factor mode

dimension statement *Dimension a string*
 SMOD:CORR:MODE? *Query instrument to return the correlation factor mode*

Comments

- **Program Type:** This command is implemented when the simulation test is selected. See PROGRAM:NAME SIMULATION (or GHOST) for more information.
- **Selecting Path Number:** Any path from 1 to 6 or 1 to 12 can be selected, however correlation factor mode is applied to the entire simulator system.
- **Returned Format:** The correlation results are returned as NONE (correlation factor disabled), 3X3, or 6X6. ("X" is the alphabet letter "X", not a multiply character).
- **Related Commands:** PROGRAM:NAME, SMODifier:CORRelation:MODE.
- Changing the correlation mode will reset all correlation values to 0.

:CORRelation?

SMODifier[<path>]:CORRelation? returns the current correlation factor for the path number specified. Refer to the Local Operation, Simulation Test presented earlier in this chapter for more information on correlation factor.

Parameters

| Parameter Name | Parameter Type | Range of Values | Default Units |
|----------------|----------------|-------------------|---------------|
| <i>path</i> | numeric | 1 to 6 or 1 to 12 | 1 |

Example

Read correlation factor for paths 1 and 4

```
dimension statement Dimension a string
SMOD:CORR?          Query instrument to return the correlation factor for paths 1 and 4
```

Comments

- **Program Type:** This command is implemented when the simulation test is selected. See PROGRAM:NAME SIMULATION (or GHOST) for more information.
- **Selecting Path Number:** Any path from 1 to 6 or 1 to 12 can be selected.
- **Returned Format:** The correlation results are returned as X.X.
- **Related Commands:** PROGRAM:NAME, SMODifier:CORRelation.

:RAYLeigh:FILENAME

SMODifier[<path>]:RAYLeigh:FILENAME<name> is used to select one of the pre-configured Rayleigh Fading Data files for use during Rayleigh Spectrum mode for the path number specified. Refer to the Local Operation, Simulation Test presented earlier in this chapter for more information on Rayleigh Fading Data files.

Parameters

| Parameter Name | Parameter Type | Range of Values | Default Units |
|----------------|----------------|--|---------------|
| <i>path</i> | numeric | 1 to 6 or 1 to 12 | 1 |
| <i>name</i> | string | 12 or less character alphanumeric string | |

Example Load RAY834.IQ for path 1

SMOD:RAYL:FILE "RAY834.IQ" *Load Rayleigh Fading Data file RAY834.IQ for path 1*

Comments

- **Program Type:** This command is implemented when the simulation test is selected. See PROGram:NAME SIMULATION (or GHOST) for more information.
- **Selecting Path Number:** Any path from 1 to 6 or 1 to 12 can be selected. If path number is not specified, path #1 is used. If the path is not available (dependent on the Simulator's option/model number), an error is generated. Setting a filename for one path changes it for all paths.
- **Entering name:** The name can be any 12 or less character alphanumeric string, including special characters (typically .IQ). If the filename cannot be found (must be in the hard disk drive directory specified using the configuration menu), an error is generated.
- **Copy Time:** Wait five to ten seconds after the command is executed for the file to be copied to the RAM Drive.
- **Related Commands:** PROGram:NAME, SMODifier:RAYLeigh:FILENAME?, SMODifier:SPECTrum.
- Changing the RAYLeigh filename for one path will change the RAYLeigh file name for all paths. The file must be in the hard drive data directory which is settable in the configuration menu.

:RAYLeigh:FILEName? **SMODifier[<path>]:RAYLeigh:FILEName?** returns the Rayleigh Fading Data file currently selected for the path number specified. Refer to the Local Operation, Simulation Test presented earlier in this chapter for more information on Rayleigh Fading Data files.

Parameters

| Parameter Name | Parameter Type | Range of Values | Default Units |
|----------------|----------------|-------------------|---------------|
| <i>path</i> | numeric | 1 to 6 or 1 to 12 | 1 |

Example Read Fading Data file currently selected for path 1

```

dimension statement Dimension a string
SMOD:RAYL:FILE?    Query instrument to return the Rayleigh
                    Fading Data filename for path 1
    
```

Comments

- **Program Type:** This command is implemented when the simulation test is selected. See PROGRAM:NAME SIMULATION (or GHOST) for more information.
- **Selecting Path Number:** Any path from 1 to 6 or 1 to 12 can be selected. If path number is not specified, path #1 is used. If the path is not available (dependent on the Simulator's option/model number), an error is generated.
- **Returned Format:** The read results are returned as a continuous "alphanumeric string".
- **Related Command:** PROGRAM:NAME, SMODifier:RAYLeigh:FILEName, SMODifier:SPECTrum.

:SPECTrum[:TYPE]

SMODifier[<path>]:SPECTrum[:TYPE]<type> is used to select one of the simulation spectrum mode for the path number specified. Refer to the Local Operation, Simulation Test presented earlier in this chapter for more information on Spectrum modes.

Parameters

| Parameter Name | Parameter Type | Range of Values | Default Units |
|----------------|----------------|----------------------------|---------------|
| <i>path</i> | numeric | 1 to 6 or 1 to 12 | 1 |
| <i>type</i> | discrete | OFF DOPPler PHASe RAYLeigh | OFF |

Example

Set path 1 to RAYLeigh mode

```
SMOD:SPEC RAYL Select Rayleigh mode for path 1
                (a Rayleigh Fading Data file must first
                be selected)
```

Comments

- **Program Type:** This command is implemented when the simulation test is selected. See PROGRAM:NAME SIMULATION (or GHOST) for more information.
- **Rayleigh Filename:** Before Rayleigh mode is to be selected for a path, a pre-configured Rayleigh Fading Data file must first be selected, using the SMODifier:RAYLeigh:FILEName command.
- **Selecting Path Number:** Any path from 1 to 6 or 1 to 12 can be selected. If path number is not specified, path #1 is used. If the path is not available (dependent on the Simulator's option/model number), an error is generated.
- **Entering type:** Each of the spectrum types are completely described earlier in this chapter under Local Operation, Simulation Test.
- **Related Commands:** PROGRAM:NAME, SMODifier:RAYLeigh:FILEName?, SMODifier:SPECTrum?.

Note



When operating in RAYLeigh mode, after a file is running, the controller should wait at least one second before sending subsequent commands to allow the interface card to reset. If this wait is not executed, the HP-IB characters or commands will be lost. In addition, any HP-IB commands will momentarily halt the RAYLeigh simulation while the command is being processed.

:SPECtrum:[TYPE]?

SMODifier[<path>]:SPECtrum[:TYPE]? returns the spectrum mode currently selected for the path number specified. Refer to the Local Operation, Simulation Test presented earlier in this chapter for more information on Spectrum modes.

Parameters

| Parameter Name | Parameter Type | Range of Values | Default Units |
|----------------|----------------|-------------------|---------------|
| <i>path</i> | numeric | 1 to 6 or 1 to 12 | 1 |

Example

Read Spectrum mode currently selected for path 1

```
dimension statement  Dimension a string
SMOD:SPEC?          Query instrument to return the spectrum mode for path 1
```

Comments

- **Program Type:** This command is implemented when the simulation test is selected. See PROGRAM:NAME SIMULATION (or GHOST) for more information.
- **Selecting Path Number:** Any path from 1 to 6 or 1 to 12 can be selected. If path number is not specified, path #1 is used. If the path is not available (dependent on the Simulator's option/model number), an error is generated.
- **Returned Format:** The read results are returned as OFF, DOPP, RAYL, or PHAS.
- **Related Commands:** PROGRAM:NAME, SMODifier:SPECtrum.

SYSTEM

The SYSTEM command subsystem is used to read errors, read the SCPI version, and perform an instrument reset.

Subsystem Syntax

```
SYSTEM
:ERRor?
:PREset
:VERSion?
```

:ERRor?

SYSTEM:ERRor? returns the next error message in the error queue. See Table 3-7 for a listing of error messages.

Example

Read the next error in the error queue

```
dimension statement  Dimension a string
SYST:ERR?           Query instrument to return the next
                    error message
```

Comments

- **Error Messages in the Error Queue.** Each error generated by the instrument stores an error message in the error queue. The error message can be up to 255 characters long (see Table 3-7).
- **Clearing the Error Queue:** An error message is removed from the queue each time the SYSTEM:ERRor? query is sent. The errors are cleared first-in, first-out. When the queue is empty, each following SYSTEM:ERRor? query returns "+0, No error". To clear all error messages in the queue, execute the *CLS command.
- **Maximum Error Messages in the Error Queue:** The queue holds a maximum of 16 error messages. If the queue overflows, the last error message in the queue is replaced by -350, "Queue overflow". The least recent error messages remain in the queue and the most recent are discarded.
- **Reading the Entire Error Queue:** The following program will read the entire error queue:

```
10 DIM B$(255)
20 OUTPUT 714;"SYST:ERR?"
30 ENTER 714; B$
40 PRINT B$
50 IF B$ <> "+0""No Error"" THEN 20
60 END
```

- ***RST or PRESet Condition:** *RST or SYSTEM:PRESet does not clear the error queue.

:PRESet

SYSTem:PRESet resets the Simulator. All parameters are reset to default values. Reset state pictured on page 3-9.

Example **Preset the Simulator**

SYST:PRES *Reset instrument*

- Comments**
- **Error Queue:** PRESet does not affect the error queue.
 - ***RST or PRESet:** *RST and SYSTem:PRESet perform the identical function.

:VERSion?

SYSTem:VERSion? returns the current SCPI version number the instrument complies with. The data is sent to the output buffer.

Example **Return the instruments SCPI version number**

SYST:VERS? *Query instrument to return version number*

- Comments**
- **Returned Format:** Return data is in the form YYYY.V, where YYYY is the year-version, and the V is the revision number for that year.
 - ***RST Conditions:** *RST does not effect revision number.

Common Commands

Table 3-2 lists the IEEE 488.2 Common (*) Commands that can be executed by the Simulator. For more information on Common Commands, refer to ANSI/IEEE Standard 488.2-1987.

Table 3-2. Common Commands

| Command | Title | Description |
|---------|--------------------------|--|
| *CLS | Clear status register | Clears all Event Registers, the Request for OPC flag, and all Queues (except output queue). |
| *ESR? | Operation complete | Always returns "0". Provided for compatibility only. |
| *IDN? | Identification query | Returns identification string of the Simulator. Returns: <i>HEWLETT-PACKARD, instrument-number, serial-number, Rev X.YY</i> . Where serial-number is always "0" and "X.YY" is the firmware revision number. |
| *OPC | Operation complete | Not implemented. Provided for compatibility only. |
| *OPC? | Operation complete query | Returns a 1 to the output queue when all pending operations have completed. |
| *RCL<n> | Recall saved state | Recalls previously stored Simulator configuration. <n> (1 to 10) is the location in memory where the desired (previously stored) set-up is located. *RCL is equivalent to MMEMOry:LOAD:STATE <number>, USER. Use MMEMOry:CATalog? command to see register names. Command is available during Simulation test only. |
| *RST | Reset | Resets the Simulator hardware and firmware to the reset state. Reset state pictured on page 3-9. |
| *SAV<n> | Save state | Stores the present Simulator configuration in memory. Stores all instrument states and parameters. <n> (1 to 10) is the location in memory where the current set-up is to be stored. Use MMEMOry:STORe:STATE command to save with a title. Command is available during Simulation test only. |
| *STB? | Operation complete | Always returns "0". Provided for compatibility only. |
| *TST? | Self-Test query | Returns 0 unless self test fails. Returns a "2" if Simulator has at least one box not answering. |
| *WAI | Wait to Continue | Halts execution of commands and queries until the No Operation Pending message is true. |

3-12. Serial Remote Operating Procedures

Procedures for executing Simulator System Serial commands using a remote terminal/computer are provided below. Refer to "Local Operating Procedures" in this chapter for instructions on performing actual tests. Remote control operating procedures using an HP-IB controller's HP-IB port are provided in paragraph 3-11.

Note



HP-IB SCPI and IEEE 488.2 commands are accepted over the serial interface.

Remote Operation

The serial remote control feature uses command lines to perform specific simulator tasks. Two forms of commands are used.

Word Commands

Word commands are well suited for use with a remote controller to control the Channel Simulator along with other hardware in one coordinated test system. These commands allow error reporting back to the remote controller after each command, and provide a way to hold off the next command until the previous command has been executed by the Simulator. Word commands are the preferred remote control technique for the Channel Simulator.

Word Command Programming

The primary remote programming method involves sending word-commands to the Vectra PC Channel Simulator software. Parameters are changed by specifying a new current path, and then the parameters to change in that path, by name.

After each word command is sent, a minimum of one message is returned to the remote controller. This message traffic is used for error checking, and also indicates when the next command can be sent.

Any remote word command can be entered into the remote controller keyboard while the simulation software is in local mode (CHANSIM). The command is echoed at the bottom of the screen, just as it would be if the software were in remote control mode. This can be used to check the syntax of a command that isn't working over the serial remote control.

Note



Single-key remote commands can be used to perform specific auxiliary functions. Because single-key commands do not return status or error messages, they are not as useful as the word commands for remote control.

A complete list of word commands are provided in tables 3-1 thru 3-3.

Single-key Command Programming

Single-key commands are normally used for auxiliary remote control. Programming begins with one-key control codes which move the cursor to choose a parameter for modification. Numbers are then sent to change the selected parameter (similar to local operation).

The Channel Simulator software does not echo back any characters in response to a single-key commands. The only indication of command execution is the action happening on the Vectra PC display. Those programs which require status and error reporting from the Channel Simulator should use Word Commands mentioned previously.

A list of Single-key control codes are provided in table 3-4.

Sending Remote Commands

Notation

When sending commands, notation is used to indicate certain control characters from the ASCII table. For example, a decimal value of 27 corresponds to the ESCAPE key in ASCII. Other values, and the notation to indicate them in this document, are:

- decimal 10 = LineFeed <lf>
- decimal 10 = NewLine <lf>
- decimal 13 = Carriage Return <cr>
- decimal 27 = Escape Key <escape>

Quote marks are used to denote what would be sent to, or read back from, the Channel Simulator over remote control. Those quote marks should never actually be sent to, or perceived as being sent by, the Channel Simulator (except for the profile titles, as noted below).

Syntax

The following guidelines must be observed when sending remote commands to the Channel Simulator:

- The Vectra PC keyboard will not read keys during remote control of the channel simulator, except for Q <esc>, and Ctl-C. If the remote control datacom connection fails, the 'Q' and the <esc> keys on the Vectra PC keyboard will escape out of any test, and then exit the main program. This avoids having to reboot the PC in the event of difficulty.
- The command(s) can be sent in either upper or lower case. They will be automatically changed to upper case by the Simulator Software.
- Each word command must be followed by a <cr>, or it will not be recognized by the Channel Simulator.
- Word commands are always echoed on the bottom of the Vectra PC display as they are received. The remote messages may be monitored by watching this display line.
- The return status of each word command should be checked after each command to catch errors and avoid overwriting the Channel

Simulator buffer. See "Error/Warning Messages" later in this chapter.

- Each returned query message from the Vectra PC back to the remote controller is always terminated by a <cr><lf> sequence.
- At least one space must separate the command from its argument, if an argument is given (e.g. DELAY 55<cr>).
- Any suffix after a numeric argument will generate an error. For example, the command "DELAY 55 ms" will return "ERROR: Needs a numeric argument".
- The numeric argument can be in either fixed or floating point notation. For example, "DELAY 5.5E+1<cr>" would be interpreted as the same delay as the command "DELAY 55<cr>".
- The units of the arguments are limited to hertz for Doppler, and microseconds for delay. If kilometers per hour and kilometers must be used for Doppler and delay, use the cursor motion single-key commands to move the cursor to the correct cell on the test's chart, and send the number to make the change.
- For queries (e.g. "MENU?") there should be no space between the command MENU and the question mark.

Main Menu Word Commands

Table 3-3 describes the word commands used to select an individual test or quit. Refer to "Local Operating Procedure" discussed previously in this chapter for actual test instructions.

Table 3-3. Word Commands for Main Menu

| Function | Local Menu Selection Key | Word Command |
|----------------------------|--------------------------|-----------------------|
| Query the software version | None | IDENTIFY? |
| Query the Current menu | None | MENU? |
| Call the Simulation Menu | S | MENU SIMULATION/GHOST |
| Call the Travel Menu | T | MENU TRAVEL |
| Quit the Channel Simulator | Q | EXIT |

NOTES:

1. When the Travel tset is run, the last saved setup is recalled and run. Any new setup must be entered and locally run (from the PC's keyboard) to completion from local PC keyboard control before it can be used remotely. Only one such setup can be saved using the travel test.
2. The SW version query returns \$ Revision: N.M \$<cr><lf>
where N and M are digits indicating the version of the Channel Simulator on the PC. This corresponds to the number in the upper left corner on the various menus.
3. The Query of the current menu returns "MAIN<cr><lf>" for the main menu.

Simulation Test Word Commands

Table 3-4 describes the word commands used to select the Channel Simulation functions. Refer to "Local Operating Procedures", Pg 3-3, discussed previously in this chapter, for actual test instructions.

Table 3-4. Word Commands for Simulation Test

| Function | Local Operation | Word Command | Notes |
|----------------------------------|-----------------|---|----------|
| Query the SW version | (See Display) | IDENTIFY? | 1 |
| Query the Current menu | (See Display) | MENU? | 6 |
| Return to main menu | <ESCAPE> | EXIT | |
| Reset the chart parameters | Ctl-<BackSpace> | RESET | |
| Set a New current path | (Cursor Motion) | PATH <n> | |
| Query the current path | (See Display) | PATH? | 9 |
| Query standard profile title | [Alt-P] | SPROFILE? <number> | 7,15 |
| Query user defined profile title | [Alt-P] | UPROFILE? <number> | 7,15 |
| Save a user defined profile | [Alt-P] | USAVE <number> "<Title>" | 7,15 |
| Recall a user defined profile | [Alt-P] | URECALL <number> | 2,3,7,15 |
| Recall a standard profile | [Alt-P] | SRECALL <number> <HzRayleigh> | 2,3,7,15 |
| For the Current Path: | | | 8 |
| Query pref menu's RF freq | (See Display) | FREQUENCY? | 13,14 |
| Set Spectrum type | (Cursor Motion) | SPECTRUM {OFF DOPPLER RAYLEIGH} | 2,3,4 |
| Query Spectrum type | (See Display) | SPECTRUM? | |
| Set delay | (Cursor Motion) | DELAY <μsec> | 10 |
| Query delay | (See Display) | DELAY? | 10,14 |
| Set Doppler | (Cursor Motion) | DOPPLER <Hz> | 2,3,12 |
| Query Doppler | (See Display) | DOPPLER? | 12,14 |
| Set attenuation | (Cursor Motion) | ATTEN <dB> | 11 |
| Query attenuation | (See Display) | ATTEN? | 11,14 |
| Set Rayleigh correlation | (Cursor Motion) | CORRELATION {.1 .2 .3 .4 .5 .6 .7 .8 .9 1.0} | 4,5 |
| Query Rayleigh correlation | (See Display) | CORRELATION? | 14 |

NOTES:

1. The SW version query returns \$ Revision: N.M \$<cr><lf> where N and M are digits indicating the version of the Channel Simulator software on the PC. This corresponds to the number in the upper left corner on the various menus.

Table 3-4. Word Commands for Simulation Test - Continued

NOTES-Continued:

2. **Warning:** If the Configuration menu has the Data directory specified differently from the Program directory, then all files ending in .IQ will be *DELETED* from the Data directory whenever a new non-zero Doppler is specified for a Rayleigh path, (or when a path with a non-zero Doppler value is made Rayleigh). This is also true for local operation from the Vectra PC keyboard.
3. Certain Rayleigh integrity checks are made whenever a path is made Rayleigh, or when the Doppler is changed on a Rayleigh path. These checks are:
 - All Rayleigh paths must be running the same Hz Doppler. The software manages these changes automatically and issues a warning that a parameter was changed.
 - The Rayleigh path Dopplers cannot have a fractional part when converted to the equivalent kmh at a 900 MHz RF frequency. The software rounds the Doppler automatically and issues a warning that a parameter was changed.
 - The Rayleigh fading .IQ datafile must already be built for the Doppler on any Rayleigh path.
 - The Rayleigh .IQ file must appear on the Data directory, or there must be enough space on the drive to accept the copy of the .IQ file from the Program directory after automatic removal of any previous .IQ files. The software will automatically copy the .IQ file to the data directory, and issue a status message that it happened.
4. The Rayleigh correlation will only be applied under the following:
 - Between path 1 and 4, -or- between path 2 and 5, -or- path 3 and 6. It is not possible to correlate any other path combinations, only these three. All 3 pairs can be pair correlated at the same time, but each pair combination will be uncorrelated with the other pairs.
 - The correlation will only happen between the two paths of the pair if BOTH the paths are in the Rayleigh spectrum mode.
 - The correlation number on the chart is marked with parentheses if either of the paths are NOT in Rayleigh mode, which indicates that the correlation is not happening between those two paths.
5. The CORRELATION numeric must be one of the following: 0, 0.1, 0.2, 0.3, 0.4, 0.5, 0.6, 0.7, 0.8, 0.9, 1.0.
6. The Query of the current menu returns "SIMULATION <cr><lf>" for this menu.
7. The entire chart setting (except for the Configuration menu specified RF frequencies) may be recalled from disk using the URECALL <n> command for user defined profiles, or SRECALL<n><HzRayleigh> for the predefined Standard Profiles, where 'n' is one of 10 possible disk file "folders" of settings. If a Rayleigh Hz Doppler value is not specified when recalling one of the standard profiles, an error message ("need floating arg") is generated.
8. If the existing chart settings are saved using USAVE<n>"e;<text>"e;, the "text" is a quote enclosed description of up to 19 characters that are to be identified with that setting, and may be queried with UPROFILE? <num>. More characters can be used in the title if you use the alt-P profile menu. All title characters entered remotely will be automatically converted to uppercase.
9. Many of the commands only effect the settings for the *current* path. Therefore, the current path must be specified with the PATH command before using these commands to change a specific path.

Table 3-4. Word Commands for Simulation Test - Continued

NOTES-Continued:

10. The current path may be queried using the PATH? query, which returns "PATH <N><cr><lf>", where N is an ascii integer between 1 and 6.
11. The <usec> argument for the DELAY command must be in microseconds. It is not possible to enter a delay in kilometers using word commands.
12. The ATTEN command's <dB> argument must be in dB.
13. The DOPPLER command must be in Hz. It is not possible to enter kmh Dopplers using the word commands.
14. The Configuration menu must be used to specify the RF frequency of the channel. This must be done under local control from the PC's keyboard.
15. All parameter queries are in the same units that are used to set the command remotely. The units of the FREQUENCY query (which cannot be set remotely) is Hz.
16. Profiles work similarly to operation from the PC keyboard. The <number> is an integer between 1 and 10 inclusive. A Title query UPROFILE? <num> or SPROFILE? <num> will return the user or standard profile title respectively, as a string included in quote marks. Any warnings found in the recalled state are printed with an OK, and any errors are printed with ??.

Travel Test Word Commands

Table 3-5 describes the word commands used to perform a travel test. Refer to "Local Operating Procedures - Travel Test" discussed previously in this chapter for actual test instructions.

Table 3-5. Word Commands for Travel Test

| Function | Local Key (Single-Key) | Word Command |
|---------------------|------------------------|--------------|
| Return to main menu | <ESCAPE> (<ESCAPE>) | <none> |

NOTES:

1. The Travel Test always runs the last saved setup. There is no way to specify a new scenario, vehicle speed, etc over remote control. Full functionality is available by local control from the Vectra PC keyboard.
2. To change Travel Test parameters, re-run the Travel Test under local control (saving setup) and let the test FINISH. This allows each path attenuation at each simulation time to be computed and saved into the scenario file. Then, restart the Channel Simulator remotely and call the Travel Test menu.
3. The remote control access to the Travel Test is minimal. The only available remote control command is to exit the test by sending the one-key <esc> (escape) key, with no terminating <cr>. The main menu will return an OK to the remote controller after the Travel Test has been exited with the <esc> (escape) key.

Single-Key Commands

Table 3-6 describes the single-key remote control codes for cursor motion & changing values on the Channel Simulation chart.

Table 3-6. Single-Key Commands

| Command | Key | Function |
|------------|------------------------------|-------------------------------------|
| Decimal 1 | HOME key (<Ctl-a>) | Cursor to upper left field on chart |
| Decimal 2 | Cursor Back Key (<Ctl-b>) | Move cursor left 1 field |
| Decimal 6 | Cursor forward key (<Ctl-f>) | Move cursor right 1 field |
| Decimal 96 | Back quote key | Toggle the path to OFF or DOPPLER. |
| Decimal 12 | Reset Chart key (<Ctl-n>) | Reset chart and hardware |
| Decimal 14 | Cursor Down (<Ctl-n>) | Move cursor down 1 field |
| Decimal 16 | Cursor Up (<Ctl-p>) | Move cursor up 1 field |

NOTES:

1. Each single-key command is sent without any other key (like <lf>, etc.)
2. **Timing Caution:** Since there is no return status after these commands, the ATE remote controller program may have to delay for a few tenths of a second to allow the PC controller to complete the one-key command. The amount of the delay is a function of the PC.
3. If the handshaking mentioned in note 2 is needed, the word commands should be used exclusively.

Error/Warning Messages

Any errors or warnings resulting from command words are printed back to the remote controller by the Channel Simulator software as soon as they are detected. The returned errors are immediately followed by "??<CR><LF>".

When programming the remote controller, error checking should be performed after each command is executed to verify that no errors have occurred. This is accomplished by waiting for either

<Error Msg> <cr><lf>

<Error Msg> <cr><lf>

<Error Msg> <cr><lf>

and ??<cr><lf>

or

OK<cr><lf>

or

<Query Msg><cr><lf> and OK<cr><lf> to be returned from the Channel Simulator after sending each word command.

Word command error and warning messages are listed alphabetically in table 3-7. A description of the error/warning, and possible cause/corrective action are also provided.

Table 3-7. Word Command Error and Warning Messages

| Error | Description |
|-------------------------------------|---|
| ERROR: Argument has too many digits | <p>The correlation factor argument for the correlation command was specified with more than one digit after the decimal point. The only allowed correlations are 0, 0.1, 0.2, 0.3, 0.4, 0.5, 0.6, 0.7, 0.8, 0.9, 1.0. Any number less than zero or greater than one would be "out of range".</p> <p>To correct this, make sure the numeric argument for the correlation command is from the above list without any extra digits.</p> |
| ERROR: Argument is out of range | <p>The numeric parameter that was supplied with the command was either too big, or too small. For example, a SMOD1:CORR -10 command would cause this error, because the only allowed correlations are 0, 0.1, 0.2, 0.3, 0.4, 0.5, 0.6, 0.7, 0.8, 0.9, 1.0. Any correlation factor less than zero or greater than one would be "out of range".</p> <p>To correct this error, make sure the numeric argument of the command being sent is within the range indicated in the above documentation for that menu's command. The range of any parameter may be easily checked by running CHANSIM (11759C) or GHOST (11759D), locally, on the Vectra PC, and entering the out of range parameter manually. A pop-up window will appear with a detailed description of the error.</p> |

Table 3-7. Word Command Error and Warning Messages - Continued

| Error | Description |
|--|---|
| ERROR: Computer too slow for realtime fade | <p>The computer was not sending the Rayleigh or IQ fading values (or the dynamic test settings) to the HP 11759 to maintain real time fading. The computer was not able to send data quickly enough at some point in the simulation.</p> <p>The result of this would be pauses in the fading scenario, where the hardware settings would remain at some value for longer than they should. Since it could cause out-of-spec fading statistics and bandwidth problems, the computer flags it as an error.</p> <p>This is often caused by running with a computer which is too slow. It can also be caused by the presence of other "TSR" (Terminate and Stay Resident) software in the computer which is using the cpu long enough to interrupt the average fading data rates to the HP 11759. LAN software, hard disk interruptions, etc can all cause this.</p> <p>Corrective actions include using a faster computer, making sure the fading data is read from a RAM disk when possible, and making sure that no other programs are running simultaneously when the HP 11759 is attempting realtime fading.</p> |
| ERROR: Data Dir too small for IQ file | <p>The Rayleigh data file could not be copied from the Program directory to the Data directory because there was not enough space on the Drive which holds the Data directory, after deleting all Data directory .IQ files which were deletable. This copy operation was needed to get the Rayleigh fading datafile to the fast Data directory for one or more of the paths which is in the Rayleigh fading mode.</p> <p>To correct this, remove files or redeclare the RAM disk such that, after all files ending in .IQ on the Data directory (that do not have their DOS Read Only attribute set) for have been removed, there is at least 3.2 Mega-bytes of available space to accept a new .IQ file via a file copy from the Program directory. In addition, the DOS command ATTRIB can be used to make sure the previous Data Directory .IQ files are not read only. This allows the software to delete the old .IQ files to make room for the new .IQ file copy.</p> <p>NOTE: The program automatically removes any file ending in .IQ from the data directory IF the data directory is something other than the program directory. This is done to make room for the copying of the new .IQ file to the data directory. This .IQ file deletion mechanism will not work if the .IQ file attributes have been set to READ ONLY. Also, an "access denied" message shows on the Vectra PC during the copying if .IQ files are set read only. That can be ignored if there is enough Data Dir space for the copy operation to work. If there is not enough space, then the program will terminate with a message saying that the datafile could not be found on the data directory.</p> <p>If the Configuration menu has been set up with the same Data directory and Program directory, then this .IQ file copy is not done, since the .IQ file should already be on the program directory. However, the Data directory can not be made the same as the Program Directory (in the Configuration menu) unless the Program directory has a fast disk cache for the Rayleigh data. See the Install program for more information.</p> |
| ERROR: Doppler specified while in Rayleigh | <p>The Doppler frequency may not be changed on a path running Rayleigh. To change the Rayleigh Doppler frequency, change the active file name using the remote SMOD[n]:RAYL:FILE command.</p> |

Table 3-7. Word Command Error and Warning Messages - Continued

| Error | Description |
|---|--|
| ERROR: Fast Directory does not exist | <p>The requested Rayleigh fading data file couldn't be copied to the fast data directory because the data directory does not exist. The file was being copied to the data directory so it could be accessed rapidly for simulating the Rayleigh in real-time.</p> <p>To correct this condition, go back to the Configuration menu and follow the prompts to specify a new Data directory. Recheck the data directory existence from the DOS prompt if desired.</p> |
| ERROR: Illegal argument | <p>The argument for a command was incorrect or out of range. For example, this error is caused by all of the following mistakes:</p> <ul style="list-style-type: none"> ■ A new spectrum was specified that was not OFF, RAYLEIGH, DOPPLER or PHASE. ■ A new delay resolution was specified that was not LOW or HIGH. <p>Modify your remote command syntax to use the arguments allowed. See the remote description for each command for details.</p> |
| ERROR: Insufficient DOS memory | <p>The program couldn't run anymore because there wasn't enough memory in the computer. This refers to the lack of "core" memory, which is commonly called conventional memory, that's in the 640K region on a PC.</p> <p>To resolve this problem, make sure your PC has 640 kbytes of RAM. If it does, then review the documentation for your computer and your operating system for directions on increasing the amount of conventional memory that is available for DOS applications. This may mandate changes to the configuration files CONFIG.SYS and/or AUTOEXEC.BAT.</p> |
| ERROR: Invalid string data | <p>The string argument for a command was either missing or incomplete, or of a bad format. The string argument must be enclosed in single or double quote marks. If the string begins with one type of quote it must end with the same type of quote.</p> <p>To correct this condition, make sure the string is printed to the PC with leading and trailing quote marks, like this example:</p> <p>SMOD1:RAYL:FILE "RAY834.IQ"</p> |
| ERROR: .IQ Copy to fast drive failed | <p>The Rayleigh data file (.IQ file) could not be copied to the fast drive. See the errors "ERROR: Data Dir too small for IQ file.", "ERROR: Fast Directory does not exist." and "ERROR: Insufficient DOS memory" for possible explanations of what may have gone wrong.</p> |
| ERROR: .IQ file's data rate is out of rng | <p>The selected Rayleigh file contains an "out of range" output data rate. This file cannot be used by the existing 11759 hardware. Try rebuilding the Rayleigh file using the IQMAKE utility.</p> |
| ERROR: .IQ file header is bad or missing | <p>The selected Rayleigh file does not contain a valid format. The file has become corrupted and must be rebuilt using the IQMAKE utility.</p> |

Table 3-7. Word Command Error and Warning Messages - Continued

| Error | Description |
|--|--|
| ERROR: IQ file not found on Hard Drive dir | <p>An attempt was made to operate a Rayleigh mode path with a Rayleigh file which was not been built. This may happen when a path is turned to Rayleigh, or the Doppler of a path which is already in Rayleigh mode is changed to use an unbuilt Rayleigh file. The Rayleigh test can only be started using already-built Rayleigh .IQ data files.</p> <p>To correct this, either specify a speed that already exists or use the IQMAKE utility to build the data file. The DOS command DIR *.IQ in the program directory will show what data files already exist.</p> <p>If the error happened during a User Profile recall, then a user defined profile call should be attempted locally. A more detailed error message will show the offending entry. That Rayleigh file could be built with IQMAKE, the .IQ file could be copied to the data directory, or a text editor could be used to change the settings in the user defined profiles file CHANSIM.PRO (11759C) or VIDEO.PRO (11759D) in the program directory.</p> |
| ERROR: Missing 11759 rear panel 10 MHz sig | <p>The HP 11759 rear-panel reference frequency is missing or it is at too low of a power level. It could also be the wrong frequency (less than 1 MHz or more than 22 MHz).</p> <p>The computer determines this by loading the HP 11759 internal FIFO with data, and then clocking it out at a time which is dependent on the rear panel 10 MHz frequency. If the FIFO never empties, then the computer concludes that the timebase frequency is missing.</p> <p>This can usually be corrected by insuring a 10 MHz signal is appearing at the rear panel 10 MHz setup. Please consult the Installation part of the manual for details on the frequency accuracy and level requirements of the rear panel TIMEBASE input signal to the HP 11759.</p> |
| ERROR: Needs a character argument | <p>A command was specified with either an incorrect argument, or with a missing argument. The command requires a legal unquoted character string. For example, this would include LOW, HIGH, RAYLEIGH, etc.</p> <p>To correct this, make sure a valid unquoted character string is supplied after the command.</p> |
| ERROR: Needs a numeric argument | <p>A command was specified with either an incorrect argument, or with a missing argument. The command requires a legal numeric value. The number may be of the form (for example) 12, 12.4, -12.4, or - 1.24E+1, etc.</p> <p>To correct this, make sure a valid numeric value is supplied after the command.</p> |
| ERROR: Needs query or argument | <p>Examples of what can cause this error:</p> <ul style="list-style-type: none"> ■ A spectrum command was used to switch the spectrum mode of the currently active path, but the name of the new spectrum mode was not specified. ■ A new correlation factor was attempted, but no correlation number was included after the command. ■ A query was desired but the ? was missing from the mnemonic. <p>Modify your remote command syntax to include the argument that is specified for that command or to include the ? in a query.</p> |

Table 3-7. Word Command Error and Warning Messages - Continued

| Error | Description |
|--|---|
| ERROR: No argument allowed with query | <p>A query syntax contained an argument after the ?, but this query does not allow an argument.</p> <p>To correct this, modify your remote query syntax to remove the argument.</p> |
| ERROR: No argument is allowed | <p>A command syntax contained an argument, but this command does not allow an argument.</p> <p>To correct this, modify your remote syntax to remove the argument.</p> |
| ERROR: Profile file was not writable | <p>The User profile file CHANSIM.PRO (11759C) or VIDEO.PRO (11759D) was not writable when the user profile command was attempted to save a user defined profile.</p> <p>To correct this error, use the various DOS commands to make sure that the file is not read-only, and use the DOS CHKDSK command to make sure that there is enough space on the program directory for the file.</p> |
| ERROR: Profiles file missing or bad format | <p>While recalling either the user defined profile, or a standard profile, there was a problem while reading the file. The file was either not available for reading, or the contents of the file contained a syntax error.</p> <p>To correct the problem, try recalling the profile while under local control from the PC keyboard. Use the Alt-P profile menu to recall the same type of profile which caused the error—standard or user defined. Then enter the number of the profile, and then select the Rayleigh data file if recalling a standard profile. The error message will provide more information on any syntax error, and then guide you to one of the following corrective actions:</p> <ul style="list-style-type: none"> ■ Re-build a new all-blank user defined profiles file CHANSIM.PRO (11759C) or VIDEO.PRO (11759D) ■ Recopy the STANDARD.PRO (11759C) or S_GHOSTS.PRO (11759D) standard profiles file from the install disk. |
| ERROR: Query DEADLOCKED | <p>This error can occur only if a query's response is too long for the 11759 to handle. This should never occur but if it does try entering the same command under local control from the PC keyboard. The error window will provide more information on any syntax error, and then guide you to a possible corrective action.</p> |
| ERROR: This is a Command only | <p>A command which can never be a query was received with a question mark after it's name.</p> <p>For example, *RST must always be sent without a trailing question mark, because it can only be used as a command.</p> <p>To correct this, make sure there is no ? following the command. See the individual command and query descriptions for details.</p> |
| ERROR: This is a Query only | <p>A command which is only supposed to be a query was received without a question mark after it's name. Or, an argument may have been supplied for the query, where only a query is allowed.</p> <p>For example, *IDN must always be sent with a trailing question mark, because it can only be used to query something.</p> <p>To correct this, make sure you only send the query form of the command. See the individual command and query descriptions for details.</p> |

Table 3-7. Word Command Error and Warning Messages - Continued

| Error | Description |
|--|--|
| ERROR: Title argument has too many chars | <p>While saving a user defined profile, the title argument was too long. The title can be a maximum of 55 characters. The title argument must be enclosed in double quote marks. To correct this condition, make sure the title is printed to the PC with leading and trailing quote marks, like this example:</p> <p>MMEM:STOR:STAT 3,"Saving a really long title into register 3"</p> |
| ERROR: Title argument is bad or missing | <p>While saving a user defined profile, the title argument was either missing or incomplete, or of a bad format.</p> <p>The title argument must be enclosed in double quote marks. To correct this condition, make sure the title is printed to the PC with leading and trailing quote marks, like this example:</p> <p>MMEM:STOR:STAT 5,"Saving to reg 5"</p> |
| ERROR: Too Many Characters | <p>The Vectra PC received too many characters on a single line (lines are ended by a <cr> in serial mode and by a <lf> in HP-IB mode). The input buffer on the 11759 software is 80 characters.</p> <p>This is a common occurrence when specifying the title for the MMEM:STOR:STAT command, which titles the profile that is being saved. The title is limited to 55 characters. Staying within this limit will not overflow the 80 character input buffer, but if a longer title is attempted the buffer could overflow.</p> <p>Correct the problem by following the command syntax, and limiting the title length to the allowed size.</p> |
| ERROR: Too many settings in same timeframe | <p>The computer tried to send too many hardware parameter settings to the HP 11759 within the time period required for those settings to be implemented.</p> <p>A real time fading scenario which downloads data from a file requires that all the hardware settings for one particular instant in the simulation be downloaded to the computer in one group, which is called a logical "frame". If too many of these settings are included in a frame, then the HP 11759 won't be able to interpret and process each of the settings before the next frame arrives.</p> <p>This can be corrected in the dynamic test by sending fewer hardware settings in the same frame. The update rate may also be slowed down, which gives the HP 11759 more time to interpret each frame of settings.</p> <p>The Rayleigh and/or IQ fading should not show this error, since those settings are all predetermined at the factory. In this case, the HP 11759 may require service.</p> |
| ERROR: Unknown Command | <p>The command that was entered is not known to the currently active Channel Simulator module. Some commands work in the main menu, and other commands work in the test menus. The right commands must be used in the right menus.</p> <p>To correct this error condition, re-send a command that works in the currently active screen. The type of screen that is currently active may be queried using the PROG:NAME? word command. It will return MAIN, TRAVEL, DYNAMIC, GHOST or SIMULATION.</p> <p>The commands allowed for each screen are listed with the detailed command descriptions.</p> |
| ERROR: <other error> | <p>The other types of errors are related to the datacom port, or the parser in the Channel Simulator software. They should be self explanatory—</p> <p>Characters overflowing the buffer</p> <p>Datacom timing or framing error</p> |

Table 3-7. Word Command Error and Warning Messages - Continued

| Error | Description |
|---|---|
| ERROR: 11759 error, BUSY line stuck high | <p>When the HP 11759 was being reset by the computer, it's handshake line was stuck in a high state. This is a very rare error.</p> <p>This is indicative of a hardware problem. There is a FIFO (first-in, first-out) memory whose data could not be flushed. That is, after an attempt to clear the data out of the FIFO, the FIFO still reported that it had more than half of it's memory filled with data.</p> <p>To correct this problem, use a Control-[BACKSPACE] to reset the test and then rerun the same sequences that caused the problem the first time. Cycling power on the HP 11759 may also clear the problem (temporarily). Also, some connections may have become unseated at the rear of the instrument, the back of the HP 11759, or inside the HP 11759 itself. Please follow the procedures in Section 8 if the HP 11759 needs to be opened to reset the connections.</p> |
| ERROR: 11759 error, BUSY line stuck low | <p>When the HP 11759 was being reset by the computer, it's handshake line was stuck in a low state. This is a very rare error.</p> <p>This is indicative of a hardware problem. There is a FIFO (first-in, first-out) memory which could not be filled more than half full of data when it was not being read, and it was being written to by the computer. It continued to report an "empty" condition well after it should have been completely filled up.</p> <p>To correct this problem, use a Control-[BACKSPACE] to reset the test and then rerun the same sequences that caused the problem the first time. Cycling power on the HP 11759 may also clear the problem (temporarily). Also, some connections may have become unseated at the rear of the instrument, the back of the HP 11759, or inside the HP 11759 itself. Please follow the procedures in Section 8 if the HP 11759 needs to be opened to reset the connections.</p> |
| ERROR: 11759 is either off or unconnected | <p>This indicates that the HP 11759 is either powered down, or it is not connected to the PC. The handshake controller in the HP 11759 is not configuring itself correctly during a HP 11759 reset sequence.</p> <p>To correct this problem, verify that the HP 11759 is powered up, connected to the computer via the parallel printer port cable, and that the cable is firmly connected at both ends. Also make sure that this parallel cable is connected to the correct LPT printer port on the computer. The LPT port which is used on the computer must match the port specification in the HP 11759 software's Configuration menu. Refer to Section 2 to verify configuration of the parallel printer port, or try running the PORTTEST program on the computer.</p> |
| ERROR: 11759 is not connected to computer | <p>This indicates that the computer was unable to find any HP 11759 connected to the LPT port which was specified in the HP 11759 software Configuration menu. The parallel printer port Select line was found to be high, and it is normally grounded through the HP 11759 when it is connected. This is pin 25 on the parallel printer port cable.</p> <p>To correct this problem, verify that the HP 11759 is powered up, connected to the computer via the parallel printer port cable, and that the cable is firmly connected at both ends. Also make sure that this parallel cable is connected to the correct LPT printer port on the computer. The LPT port which is used on the computer must match the port specification in the HP 11759 software's Configuration menu. Consult your computer manual to verify configuration of the parallel printer port, or try running the PORTTEST program on the computer.</p> |

Table 3-7. Word Command Error and Warning Messages - Continued

| Error | Description |
|---|---|
| <p>ERROR: 11759 Rear Panel 10 MHz is wrong freq</p> | <p>The HP 11759 rear-panel reference frequency is either at the wrong frequency, or it's levels are incorrect.</p> <p>The computer determines this by loading the HP 11759 internal FIFO with data, and then clocking it out at a time which is dependent on the rear panel 10 MHz frequency. If the FIFO empties too quickly or too slowly relative to the computer's internal timer, then the computer concludes that the frequency is incorrect.</p> <p>This can usually be corrected by insuring a 10 MHz signal is appearing at the rear panel 10 MHz setup. Refer to Section 2 for details on the frequency accuracy and level requirements of the rear panel TIMEBASE input signal to the HP 11759.</p> |
| <p>ERROR: 6x6 Correlation tried with 6 paths</p> | <p>The correlation mode of 6X6 was attempted with a HP 11759 that only has 6 paths. 6X6 correlation mode can only be used on a 12 path system.</p> <p>If you have a 12 path system, use the Configuration menu to change the number of units in the system. If you have only 6 paths, only use correlation modes of 3X3 or NONE.</p> |
| <p>WARNING: Delay value was rounded</p> | <p>The delay value for a path was rounded. If using LOW delay resolution mode, the delay was rounded to the nearest 50 ns. If using HIGH delay resolution, the delay was rounded to the nearest 1 ns.</p> <p>This warning can be safely ignored, as long as the rounded value meets the simulation requirements.</p> |
| <p>WARNING: No correlation, pair not Rayleigh</p> | <p>Rayleigh correlation was specified for a path whose Spectrum mode is not Rayleigh, or whose associated path in the other channel is not Rayleigh.</p> <p>This warning may only be ignored if correlation is not expected between the current path and it's pair, or if both paths in the pair will be made Rayleigh before correlation simulation is desired.</p> <p>When the correlation mode is 3X3, the paths in each path pair of 1&4, 2&5, and 3&6 may only be pairwise correlated if both members of the pair are in the Rayleigh spectrum mode. For example, if path 3 is in Rayleigh spectrum mode and path 6 is in Rayleigh spectrum mode, then the correlation for path 3 or path 6 may be specified. If either path is either OFF or DOPPLER, then this warning message will be issued.</p> |

Performance Tests

4-1. Introduction

This chapter normally contains information used to test the Simulator's electrical performance against the specifications of Table A-1. The only tests that can be performed by the user are contained in Chapter 2, System Verification Check. Refer to STORAGE AND SHIPMENT in Chapter 2 for information about returning the instrument for service.

Adjustments

5-1. Introduction

This chapter contains adjustments of the Simulator. This instrument need only be readjusted after repair AND a failed System Verification Check (refer to Chapter 2). Allow 30 minutes warm-up prior to performing the adjustments.

5-2. Safety Considerations

This section contains information, cautions and warnings which must be followed for your protection and to avoid damage to the equipment.

Warning



Adjustments described in this section are performed with power supplied to the instrument and with protective covers removed. Adjustments should only be performed by service trained personnel who are aware of the hazard involved. Where adjustments can be performed without power applied, the power should be removed.

5-3. Equipment Required

Test equipment and accessories required to perform the adjustments are listed in Table A-3. Equipment other than the recommended model can be used provided the critical specifications are satisfied.

5-4. Adjustment Procedure

Adjustments of the Path Assemblies path to path insertion loss are performed as follows:

Refer to Chapter 8 for information on Path Assembly and adjustment locations.

Equipment

| | |
|---------------------------------|-----------------------------|
| Computer | HP Vectra 486/33U (minimum) |
| Spectrum Analyzer | HP 8566B |
| Signal Generator (2 each) | HP 8657B |

Procedure

1. Connect the test equipment as shown in figure 5-1.

Note

The standard instrument is shown in figure 5-1. Connection to instruments with options is the same, making connections on the rear panel in lieu of the front panel when necessary.

2. Set the signal source controls as follows:

FREQUENCY 900 MHz
 OUTPUT LEVEL -10 dBm

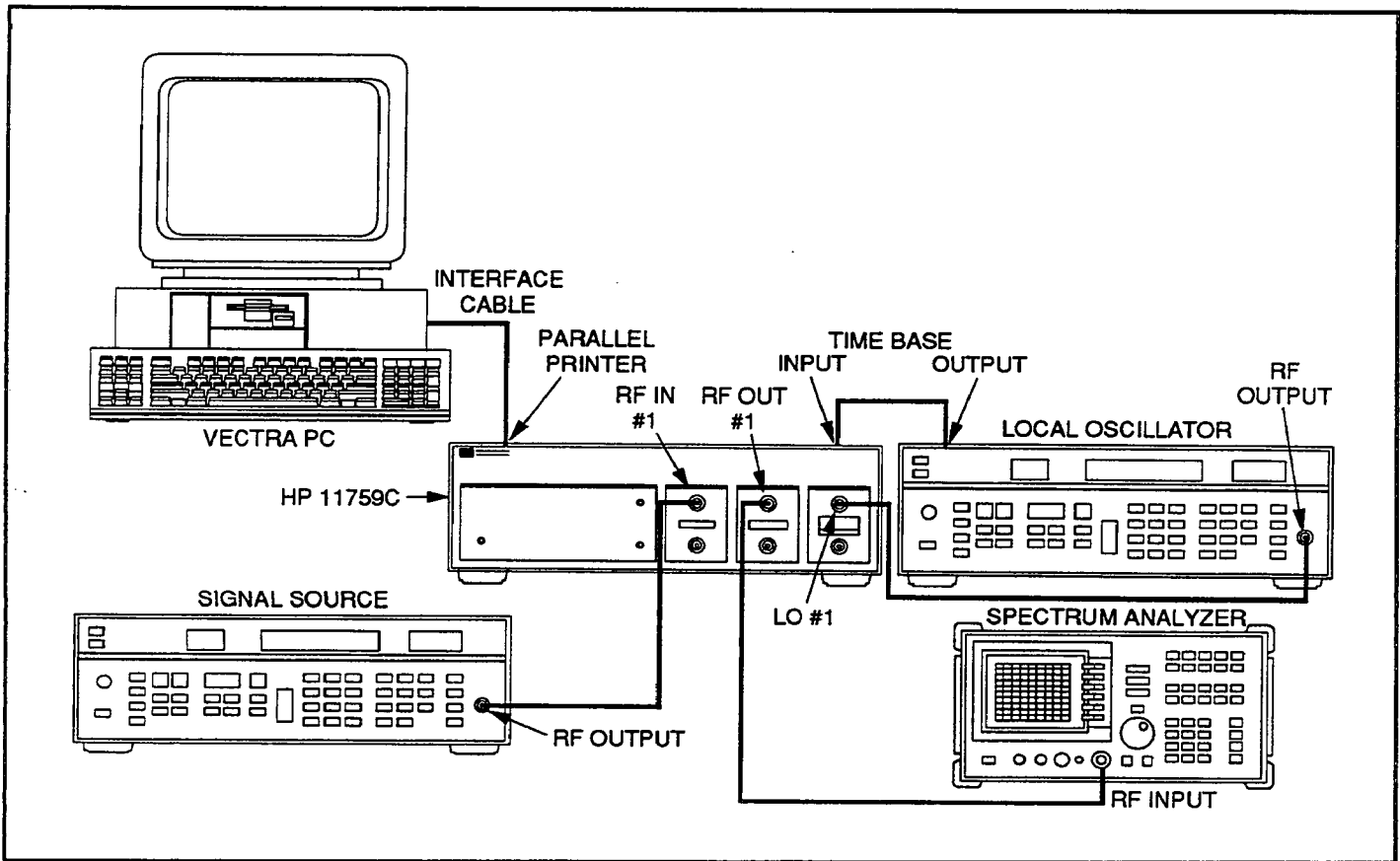

Figure 5-1. Path to Path Insertion Loss Adjustment Setup

3. Set the local oscillator controls as follows:

FREQUENCY 894 MHz
 OUTPUT LEVEL +10 dBm

4. Set the spectrum analyzer controls as follows:

CENTER FREQUENCY 900 MHz
 FREQ SPAN 10 KHz
 REF LEVEL -30 dBm
 DBM/DIV 1 dB/Div

5. Reset the HP 11759C by pressing the "CTRL-BACKSPACE" keys, then set PATH #1 SPECTRUM to Doppler.

6. Set the spectrum analyzer controls as follows:
 - PressPEAK SEARCH
 - Record the measured level (must be greater than -40 dBm)
 - PressMARKER DELTA
7. Set the HP 11759C PATH #1 SPECTRUM to OFF, and the PATH #2 SPECTRUM to Doppler.
8. On the spectrum analyzer, press PEAK SEARCH and record the measured level. Verify the difference between path #1 and path #2 recorded levels is less than 0.1 dB.
 - If the difference between paths is more than 0.1 dB, remove the top cover (see Chapter 8, Repair) and adjust A2A1R23 until the reading is within specified limits.
9. Set the HP 11759C PATH #2 SPECTRUM to OFF, and the PATH #3 SPECTRUM to Doppler.
10. On the spectrum analyzer, press PEAK SEARCH and record the measured level. Verify the difference between Path #1 and Path #3 recorded levels is less than 0.1 dB.
 - If the difference between paths is more than 0.1 dB, remove the top cover (see Chapter 8, Repair) and adjust A3A1R23 until the reading is within specified limits.
11. Repeat steps 5 through 10 for:
 - *Standard and Option 002:* channel 2 substituting path 4 for path 1, path 5 for path 2, and path 6 for path 3. Adjust A5A5R23 and A6A1R23 as required.
 - *Option 001 and 003:* substituting path 4 for path 1, path 5 for path 2, and path 6 for path 3. Adjust A5A1R23 and A6A1R23 as required.
12. Remove power and disconnect test equipment. Replace top cover.

Replaceable Parts

6-1. Introduction

This section contains information for ordering parts. Table 6-1 lists abbreviations used in the parts list and throughout the manual. Table 6-2 lists all replaceable parts in reference designation order.

6-2. Abbreviations

Tables 6-1 to 6-3 list the reference designations, abbreviations, and multipliers used in the parts list, block diagrams, and throughout the manual. In some cases, two forms of the abbreviation are used; one, all capital letters, and one partial or no capitals. However, in the schematics and other parts of the manual, other abbreviation forms are used with lower case and upper case letters.

6-3. Replaceable Parts

Table 6-4 lists all replaceable parts in reference designator order. Figure 6-1 shows the location of major components. Figure 6-2 identifies cabinet parts.

Table 6-4 also lists assemblies within the instrument that may be replaced on an exchange basis. Exchange, factory-repaired and tested assemblies are available only on a trade-in basis. Defective assemblies must be returned for credit. Assemblies required for spare parts stock must be ordered by the new assembly part number.

6-4. Parts List Updating

Simulators made after the publication of this manual may have different parts than the ones shown in the replaceable parts list. They will have serial number prefixes higher than the one(s) described on the title page. Refer to the MANUAL CHANGES supplement that accompanies these instruments for parts information. The Manual Changes supplement also contains instructions for correcting errors in the replaceable parts list.

6-5. Ordering Information

To order a part listed in the replaceable parts list, quote the Hewlett-Packard part number and indicate the quantity required. Address the order to the nearest Hewlett-Packard office (see NOTE below). To order a part that is not in the replaceable parts table, include the instrument model number, instrument serial number, the description and function of the part, and the number of parts required.

Note



Within the USA, it is better to order directly from the HP Parts Center at (800) 227-8164, or contact your nearest HP sales office for complete information.

Table 6-1. Reference Designations

| | | | |
|---|---|---|--|
| <p>A assembly AT attenuator; isolator; termination B fan; motor BT battery C capacitor CP coupler CR diode; diode thyristor; varactor DC directional coupler DL delay line DS annunciator; signaling device (audible or visual); lamp; LED</p> | <p>E miscellaneous electrical part F fuse FL filter H hardware HY circulator J electrical connector (stationary portion); jack K relay L coil; inductor M meter MP miscellaneous mechanical part</p> | <p>P electrical connector (movable portion); plug Q transistor; SCR; triode thyristor R resistor RT thermistor S switch T transformer TB terminal board TC thermocouple TP test point U integrated circuit; microcircuit</p> | <p>V electron tube VR voltage regulator; breakdown diode W cable; transmission path; wire X socket Y crystal unit (piezoelectric or quartz) Z tuned cavity; tuned circuit</p> |
|---|---|---|--|

Table 6-2. Abbreviations

| | | | |
|---|---|--|--|
| <p>A ampere ac alternating current ACCESS accessory ADJ adjustment A/D analog-to-digital AF audio frequency AFC automatic frequency control AGC automatic gain control AL aluminum ALC automatic level control AM amplitude modulation AMPL amplifier APC automatic phase control ASSY assembly AUX auxiliary avg average AWG American wire gauge BAL balance BCD binary coded decimal BD board BE CU beryllium copper BFO beat frequency oscillator BH binder head BKDN breakdown BP bandpass BPF bandpass filter BRS brass BWO backward-wave oscillator CAL calibrate ccw counterclockwise CER ceramic CHAN channel cm centimeter CMO cabinet mount only COAX coaxial COEF coefficient COM common COMP composition COMPL complete CONN connector CP cadmium plate CRT cathode-ray tube CTL complementary transistor logic CW continuous wave cw clockwise</p> | <p>cm centimetre D/A digital-to-analog dB decibel dBm decibel referred to 1 mW dc direct current deg degree (temperature interval or difference) ° degree (plane angle) °C degree Celsius (centigrade) °F degree Fahrenheit °K degree Kelvin DEPC deposited carbon DET detector diam diameter DIA diameter (used in Parts List) DIFF AMPL differential amplifier div division DPDT double-pole, double-throw DR drive DSB double sideband DTL diode transistor logic DVM digital voltmeter ECL emitter coupled logic EMF electromotive force EDP electronic data processing ELECT electrolytic ENCAP encapsulated EXT external F farad FET field-effect transistor F/F flip-flop FH flat head FIL H fillister head FM frequency modulation FP front panel FREQ frequency FXD fixed g gram GE germanium GHz gigahertz GL glass GRD ground(ed) H henry h hour</p> | <p>HET heterodyne HEX hexagonal HD head HDW hardware HF high frequency HG mercury HI high HP Hewlett-Packard HPF high-pass filter HR hour (used in Parts List) HV high voltage Hz Hertz IC integrated circuit ID inside diameter IF intermediate frequency IMPG impregnated in inch INCD incandescent INCL include(s) INP input INS insulation INT internal kg kilogram kHz kilohertz kΩ kilohm kV kilovolt lb pound LC inductance-capacitance LED light-emitting diode LF low frequency LG long LH left hand LIM limit LIN linear taper (used in Parts List) lin linear LK WASH lock washer LO low; local oscillator LOG logarithmic taper (used in Parts List) log logarithm(ic) LPF low pass filter LV low voltage m metre (distance) mA millampere MAX maximum MΩ megohm</p> | <p>MEG meg (10⁶) (used in Parts List) MET FLM metal film MET OX metallic oxide MF medium frequency; microfarad (used in Parts List) MFR manufacturer mg milligram MHz megahertz mH millihenry mho mho MIN minimum min minute (time) ' minute (plane angle) MINAT miniature mm millimetre MOD modulator MOM momentary MOS metal-oxide semiconductor ms millisecond MTG mounting MTR meter (indicating device) mV millivolt mVac millivolt, ac mVdc millivolt, dc mVpk millivolt, peak mVp-p millivolt, peak-to-peak mVrms millivolt, rms mW milliwatt MUX multiplex MY mylar μA microampere μF microfarad μH microhenry μmho micromho μs microsecond μV microvolt μVac microvolt, ac μVdc microvolt, dc μVpk microvolt, peak μVp-p microvolt, peak-to-peak μVrms microvolt, rms μW microwatt</p> |
|---|---|--|--|

Table 6-2. Abbreviations (continued)

| | | | |
|--|---|---|---|
| nA nanoampere | PIV peak inverse voltage | R&P rack and panel | TV television |
| NC no connection | pk peak | RWV reverse working voltage | TVI television interference |
| N/C normally closed | PL phase lock | S scattering parameter | TWT traveling wave tube |
| NE neon | FLO phase lock oscillator | s second (time) | U micro (10 ⁻⁶) |
| NEG negative | PM phase modulation | ... " second (plane angle) | (used in Parts List) |
| nF nanofarad | PNP positive-negative-positive | S-B slow-blow (fuse) | UF microfarad (used in Parts |
| NI PL nickel plate | P/O part of | (used in Parts List) | List) |
| N/O normally open | POLY polystyrene | SCR silicon controlled rectifier; | UHF ultra-high frequency |
| NOM nominal | PORC porcelain | screw | UNREG unregulated |
| NORM normal | POS positive; position(s) (used | SE selenium | V volt |
| NPN negative-positive-negative | in Parts List) | SECT sections | VA voltampere |
| NPO negative-positive | POSN position | SEMICON semiconductor | Vac volts, ac |
| zero (zero temperature | POT potentiometer | SHF super-high frequency | VAR variable |
| coefficient) | p-p peak-to-peak | SI silicon | VCO voltage-controlled |
| NRFR not recommended for | PP peak-to-peak (used in Parts | SIL silver | oscillator |
| field replacement | List) | SL slide | Vdc volts, dc |
| NSR not separately | PPM pulse-position | SNR signal-to-noise ratio | VDCW volts, dc, working |
| replaceable | modulation | SPDT single-pole, | (used in Parts List) |
| ns nanosecond | PREAMPL preamplifier | double-throw | V(F) volts, filtered |
| nW nanowatt | PRF pulse-repetition frequency | SPG spring | VFO variable-frequency |
| OBD order by description | PRR pulse repetition rate | SR split ring | oscillator |
| OD outside diameter | ps picosecond | SPST single-pole, single-throw | VHF very-high frequency |
| OH oval head | PT point | SSB single sideband | Vpk volts, peak |
| OP AMPL operational | PTM pulse-time modulation | SST stainless steel | Vp-p volts, peak-to-peak |
| amplifier | PWM pulse-width modulation | STL steel | Vrms volts, rms |
| OPT option | PWV peak working voltage | SQ square | VSWR voltage standing-wave |
| OSC oscillator | RC resistance-capacitance | SWR standing-wave ratio | ratio |
| OX oxide | RECT rectifier | SYNC synchronize | VTO voltage-tuned oscillator |
| oz ounce | REF reference | T timed (slow-blow fuse) | VTVM vacuum-tube voltmeter |
| Ω ohm | REG regulated | TA tantalum | V(X) volts, switched |
| P peak (used in Parts List) | REPL replaceable | TC temperature compensating | W watt |
| PAM pulse-amplitude | RF radio frequency | TD time delay | W/ with |
| modulation | RFI radio frequency | TERM terminal | WIV working inverse voltage |
| PC printed circuit | interference | TFT thin-film transistor | WW wirewound |
| PCM pulse-code modulation; | RH round head; right hand | TGL toggle | W/O without |
| pulse-count modulation | RLC resistance-inductance- | THD thread | YIG yttrium-iron-garnet |
| PDM pulse-duration | capacitance | THRU through | Z ₀ characteristic impedance |
| modulation | RMO rack mount only | TI titanium | |
| pF picofarad | rms root-mean-square | TOL tolerance | |
| PH BRZ phosphor bronze | RND round | TRIM trimmer | |
| PHL Phillips | RAM random-access memory | TSTR transistor | |
| PIN positive-intrinsic- | ROM read-only memory | TTL transistor-transistor logic | |
| negative | | | |

Table 6-3. Multipliers

| Abbreviation | Prefix | Multiple |
|--------------|--------|-------------------|
| T | tera | 10 ¹² |
| G | giga | 10 ⁹ |
| M | mega | 10 ⁶ |
| k | kilo | 10 ³ |
| da | deka | 10 |
| d | deci | 10 ⁻¹ |
| c | centi | 10 ⁻² |
| m | milli | 10 ⁻³ |
| μ | micro | 10 ⁻⁶ |
| n | nano | 10 ⁻⁹ |
| p | pico | 10 ⁻¹² |
| f | femto | 10 ⁻¹⁵ |
| a | atto | 10 ⁻¹⁸ |

Table 6-4. Replaceable Electrical Parts

| Reference Designation | HP Part No. | Qty | Description |
|-----------------------|-------------|-----|--|
| A1 | 11759-60055 | 6 | Path Assembly (Path #1) |
| A2 | 11759-60055 | | Path Assembly (Path #2) |
| A3 | 11759-60055 | | Path Assembly (Path #3) |
| A4 | 11759-60055 | | Path Assembly (Path #4) |
| A5 | 11759-60055 | | Path Assembly (Path #5) |
| A6 | 11759-60055 | | Path Assembly (Path #6) |
| A7 | 11759-60050 | 2 | Synchronizer Assembly (Channel 1) |
| A8 | 11759-60050 | | Synchronizer Assembly (Channel 2) |
| A9 | 11759-60051 | 4 | Down Converter Printed Circuit Assembly (Channel 1) |
| A10 | 11759-60051 | | Up Converter Printed Circuit Assembly (Channel 1) |
| A11 | 11759-60051 | | Down Converter Printed Circuit Assembly (Channel 2) (STD and OPT 002 only) |
| A12 | 11759-60051 | | Up Converter Printed Circuit Assembly (Channel 2) (STD and OPT 002 only) |
| A13 | 11759-60052 | 1 | Clock/Divider Printed Circuit Assembly |
| A14 | 0950-2261 | 1 | Power Supply Assembly |
| A15 | 11759-60065 | 1 | Line Module Cable Assembly |
| A16 | 11759-60014 | 1 | Fan Assembly |
| A17 | 11759-60061 | | LED Cable Assembly (Green) To A13J22 |
| A18 | 11759-60062 | | LED Cable Assembly (Yellow) To A7J6 |
| A19 | 11759-60062 | | LED Cable Assembly (STD and OPT 002 only) (yellow) To A8J6 |
| F1 | 2110-0924 | 1 | Fuse 3.5A 250V NTD FE UL (90 to 132 VAC Operation) |
| F1 | 2110-0633 | 1 | Fuse T2.5A 250V TD IEC (190 to 264 VAC Operation) |
| W1 | 86790-60001 | 1 | Cable Assembly (Brown), A13J1 to 10MHz Rear Panel |
| W2 | 86730-60041 | 5 | Cable Assembly (White), A13J2 to A6J7 |
| W3 | 86730-60041 | | Cable Assembly (White), A13J3 to A5J7 |
| W4 | 86730-60041 | | Cable Assembly (White), A13J4 to A4J7 |
| W5 | 08980-60033 | 3 | Cable Assembly (Gray/Orange), A13J5 to A1J7 |
| W6 | 08980-60033 | | Cable Assembly (Gray/Orange), A13J6 to A2J7 |
| W7 | 08980-60033 | | Cable Assembly (Gray/Orange), A13J7 to A3J7 |
| W8 | 08673-60149 | 3 | Cable Assembly (White/Red), A13J8 to A4J4 |
| W9 | 08673-60149 | | Cable Assembly (White/Red), A13J9 to A5J4 |
| W10 | 08673-60149 | | Cable Assembly (White/Red), A13J10 to J8 |
| W11 | 11759-60033 | 3 | Cable Assembly (Yellow), A13J11 to A1J4 |
| W12 | 11759-60033 | | Cable Assembly (Yellow), A13J12 to A2J4 |
| W13 | 11759-60033 | | Cable Assembly (Yellow), A13J13 to J8 |
| W14 | 11759-60038 | 1 | Cable Assembly (Gray), A13J14 to A14 |
| W15 | 11759-60042 | 4 | Cable Assembly (Red), A13J15 to A10 Feedthru (STD and OPT 002 only) |
| W16 | 11759-60042 | | Cable Assembly (Red), A13J16 to A12 Feedthru |
| W17 | 11759-60042 | | Cable Assembly (Red), A13J17 to A9 Feedthru (STD and OPT 002 only) |
| W18 | 11759-60042 | | Cable Assembly (Red), A13J18 to A11 Feedthru |
| W19 | 11759-60034 | 6 | Power Cable Assembly, A13J19 to A1J6 |
| W20 | 11759-60034 | | Power Cable Assembly, A13J20 to A2J6 |
| W21 | 11759-60034 | | Power Cable Assembly, A13J21 to A3J6 |

Table 6-4. Replaceable Electrical Parts

| Reference Designation | HP Part No. | Qty | Description |
|-----------------------|-------------|-----|--|
| W22 | | | Not Assigned |
| W23 | 11759-60034 | | Power Cable Assembly, A13J23 to A4J6 |
| W24 | 11759-60034 | | Power Cable Assembly, A13J24 to A5J6 |
| W25 | 11759-60034 | | Power Cable Assembly, A13J25 to A6J6 |
| W26 | 11759-60064 | 1 | Cable Assembly (Green), A11J8 to A1J3 (OPT 001/003 only) |
| W26 | 11759-60067 | 1 | Cable Assembly (Blue), A9J8 to A1J3 (STD/OPT 002 only) |
| W27 | 11759-60064 | | Cable Assembly (Green), A11J9 to A2J3 (OPT 001/003 only) |
| W27 | 11759-60067 | | Cable Assembly (Blue), A9J9 to A2J3 (STD/OPT 002 only) |
| W28 | 11759-60064 | | Cable Assembly (Green), A11J10 to A3J3 (OPT 001/003 only) |
| W28 | 11759-60067 | | Cable Assembly (Blue), A9J10 to A3J3 (STD/OPT 002 only) |
| W29 | 08780-60082 | 2 | Cable Assembly (Blue), A9Blue to A10Blue |
| W30 | 11759-60066 | 1 | Cable Assembly (Yellow), A12J8 to A1J2 (OPT 001/003 only) Cable Assembly (Yellow), A10J8 to A1J2 (STD/OPT 002 only) |
| W31 | 11759-60066 | | Cable Assembly (Yellow), A12J9 to A2J2 (OPT 001/003 only) Cable Assembly (Yellow), A10J9 to A2J2 (STD/OPT 002 only) |
| W32 | 11759-60066 | | Cable Assembly (Yellow), A12J10 to A3J2 (OPT 001/003 only) Cable Assembly (Yellow), A10J10 to A3J2 (STD/OPT 002 only) |
| W33 | 11759-60067 | 1 | Cable Assembly (Blue), A11J5 to A4J3 (OPT 001/003 only) |
| W33 | 11759-60064 | 1 | Cable Assembly (Green), A11J8 to A4J3 (STD/OPT 002 only) |
| W34 | 11759-60067 | | Cable Assembly (Blue), A11J6 to A5J3 (OPT 001/003 only) |
| W34 | 11759-60064 | | Cable Assembly (Green), A11J9 to A5J3 (STD/OPT 002 only) |
| W35 | 11759-60067 | | Cable Assembly (Blue), A11J7 to A6J3 (OPT 001/003 only) |
| W35 | 11759-60064 | | Cable Assembly (Green), A11J10 to A6J3 (STD/OPT 002 only) |
| W36 | 08780-60082 | | Cable Assembly (Blue), A11Blue to A12Blue |
| W37 | 11759-60063 | 1 | Cable Assembly (Violet), A12J5 to A4J2 (OPT 001/003 only) Cable Assembly (Violet), A12J8 to A4J2 (STD/OPT 002 only) |
| W38 | 11759-60063 | | Cable Assembly (Violet), A12J6 to A5J2 (OPT 001/003 only) Cable Assembly (Violet), A12J9 to A5J2 (STD/OPT 002 only) |
| W39 | 11759-60063 | | Cable Assembly (Violet), A12J7 to A6J2 (OPT 001/003 only) Cable Assembly (Violet), A12J10 to A6J2 (STD/OPT 002 only) |
| W40 | 11759-60040 | 2 | Cable Assembly (Gray), Aux LO #1 to A10 AUX LO |
| W41 | | | Not Assigned |
| W42 | 11759-60039 | 6 | Cable Assembly (Gray), Channel 1 RF Input to A9 RF Input (STD/OPT 001) |
| W42 | 11759-60040 | 6 | Cable Assembly (Gray), Channel 1 RF Input to A9 RF Input (STD/OPT 002/003) |
| W43 | 11759-60039 | | Cable Assembly (Gray), Channel 1 RF Output to A10 RF Output (STD/OPT 001) |
| W43 | 11759-60040 | | Cable Assembly (Gray), Channel 1 RF Output to A10 RF Output (OPT 002/003) |
| W44 | 11759-60039 | | Cable Assembly (Gray), Channel 1 LO Input to A9 LO Input (STD/OPT 001) |
| W44 | 11759-60040 | | Cable Assembly (Gray), Channel 1 LO Input to A9 LO Input (OPT 002/003) |
| W45 | 11759-60039 | | Cable Assembly (Gray), Channel 2 RF Input to A11 RF Input (STD) |
| W45 | 11759-60040 | | Cable Assembly (Gray), Channel 2 RF Input to A11 RF Input (OPT 002) |
| W46 | 11759-60039 | | Cable Assembly (Gray), Channel 2 RF Output to A12 RF Output (STD) |
| W46 | 11759-60040 | | Cable Assembly (Gray), Channel 2 RF Output to A12 RF Output (OPT 002) |

Table 6-4. Replaceable Electrical Parts

| Reference Designation | HP Part No. | Qty | Description |
|-----------------------|-------------|-----|---|
| W47 | 11759-60039 | | Cable Assembly (Gray), Channel 2 LO Input to A11 LO Input (STD) |
| W47 | 11759-60040 | | Cable Assembly (Gray), Channel 2 LO Input to A11 LO Input (OPT 002) |
| W48 | 11759-60068 | 1 | Centronic Cable Assembly, Rear Panel to A7/A8 |
| W49 | 11759-60041 | | Cable Assembly (White), A7 to A3J4 |
| W50 | 86730-60041 | | Cable Assembly (White), A8 to A6J4 |
| W51 | 11759-60040 | | Cable Assembly (Gray), AUX LO #2 To A12 AUX LO |
| W52 | 11759-60069 | | External Centronic Cable Assembly |
| CABINET PARTS | | | |
| MP1 | 11759-00021 | 1 | Subpanel Front |
| MP2 | 11759-00022 | 1 | Panel-Rear |
| MP3 | 11759-00003 | 1 | Deck-Main |
| MP4 | 11759-00004 | 1 | Bracket-Left A14 |
| MP5 | 11759-00005 | 2 | Cover-Upconverter A10 |
| MP6 | 11759-00005 | | Cover-Upconverter A12 (STD/OPT 002) |
| MP7 | 11759-00006 | 1 | Bracket-Z A14 |
| MP8 | 11759-00007 | 2 | Cover-Downconverter A9 |
| MP9 | 11759-00007 | | Cover-Downconverter A11 |
| MP10 | 11759-00008 | 1 | Deck-Converter (STD/OPT 002) |
| MP11 | 11759-00015 | 1 | Panel-Front Dress (STD) |
| MP11 | 11759-00016 | 1 | Panel-Front Dress (OPT 001, 002, 003) |
| MP12 | 1460-1345 | 2 | Stand-Tilt |
| MP13 | 1460-1345 | | Stand-Tilt |
| MP14 | 3160-0444 | 2 | Fan Grill |
| MP15 | 5001-0539 | 2 | Trim-Front Side 5.25 in Long |
| MP16 | 5001-0539 | | Trim-Front Side 5.25 in Long |
| MP17 | 5021-5838 | 2 | Strut Side |
| MP18 | 5021-5838 | | Strut Side |
| MP19 | 5021-8403 | 1 | Frame-Front |
| MP20 | 5041-8801 | 4 | Foot-Full |
| MP21 | 5041-8801 | | Foot-Full |
| MP22 | 5041-8801 | | Foot-Full |
| MP23 | 5041-8801 | | Foot-Full |
| MP24 | 5041-8802 | 1 | Trim-Front Top |
| MP25 | 5041-8819 | 2 | Cap-side Handle-Front |
| MP26 | 5041-8819 | | Cap-side Handle-Front |
| MP27 | 5041-8820 | 2 | Cap-side Handle-Rear |
| MP28 | 5041-8820 | | Cap-side Handle-Rear |
| MP29 | 5041-8821 | 4 | Standoff, Rear |
| MP30 | 5041-8821 | | Standoff, Rear |
| MP31 | 5041-8821 | | Standoff, Rear |

Table 6-4. Replaceable Electrical Parts

| Reference Designation | HP Part No. | Qty | Description |
|-----------------------|-------------|-----|--|
| MP32 | 5041-8821 | | Standoff, Rear |
| MP33 | 5062-3705 | 2 | Strap-Side Handle 21 in |
| MP34 | 5062-3705 | | Strap-Side Handle 21 in |
| MP35 | 86793-00014 | 1 | Cover, Top |
| MP36 | 86793-00013 | 1 | Cover, Bottom |
| MP39 | 8160-0507 | 9 | Radio Frequency Interference Shielding, Feet |
| MP40 | 6960-0027 | 6 | Plug-Button |
| MP41 | 11759-00025 | 1 | Line Module Cover |
| MP42 | 11759-00026 | 1 | Cable Bracket |
| MP43 | 11759-00027 | 1 | Clamp |
| | 0380-1677 | 20 | Standoff-Hex 32mm Lg M3.0 x 0.5 Thread |
| | 0380-1900 | 4 | Spacer-Round .688in |
| | 0515-0168 | 1 | Screw-Machine M3.5 x 0.6 6mm Long |
| | 0515-0372 | 2 | Screw-Machine M3.5 X 0.5 8mm long |
| | 0515-0664 | 2 | Screw-Machine M3 x 0.5 12mm Long |
| | 0515-0430 | 32 | Screw-Machine M3 x 0.5 6mm Long |
| | 0515-0667 | 16 | Screw-Machine M3 x 0.5 25mm Long |
| | 0515-1132 | 4 | Screw-Machine M5 x 0.8 12mm Long |
| | 0515-1382 | 6 | Screw-Machine M3.5 x 0.6 6mm Long |
| | 0515-1402 | 4 | Screw-Machine M3.5 x 0.6 8mm Long Pan Head Pozidriv |
| | 0515-1946 | 20 | Screw-Machine M3.0 x 0.5 |
| | 0515-1785 | 4 | Screw-Machine M3.5 x 0.6 40mm Long |
| | 0515-2086 | 16 | Screw-Bolt Metric |
| | 1252-0553 | 2 | Screw-Machine 4-40 3/16 hex head (Kit Contains 2 Each) |
| | 1400-0510 | 1 | Cable Clamp |
| | 1400-0482 | 2 | Cable Tie |
| | 1400-0249 | 11 | Cable Tie |
| | 2190-0102 | 1 | Washer-Lock Internal Tooth 15/32 in .472in-Inside Diameter |
| | 2190-0104 | 6 | Washer-Lock Internal Tooth 7/16 in .439 Inside Diameter |
| | 2190-0120 | 2 | Washer-Lock Internal Tooth 5/8 in .64 Inside Diameter |
| | 2190-0645 | 4 | Washer-Lock External Tooth -b 3.5mm 3.65mm-Inside Diameter |
| | 2360-0115 | 4 | Screw-Machine 6-32 .312in Lg PAN HEAD POZIDRIV |
| | 2360-0129 | 5 | Screw-Machine 6-32 1in Lg Pan Head Pozidriv |
| | 2360-0334 | 4 | Screw-Machine 6-32 .312in Lg 100deg Flat Head |
| | 2950-0035 | 1 | Nut-Hex-Double-Chamfer 15/32-32th |
| | 2950-0078 | 16 | Nut-Hex-Double-Chamfer 10-32thd .067 in-Thick |
| | 2950-0132 | 12 | Nut-Hex-Double-Chamfer 7/16-28thd .094 in-Thick |
| | 2950-0213 | 2 | Nut-Hex-Double-Chamfer 5/8-24thd .125 in-Thick |
| | 0535-0004 | 2 | Nut-Hex-Double-Chamfer M3.0 x 0.5 |
| | 0535-0007 | 4 | Nut-Hex-Double-Chamfer M3.5 x 0.6 |

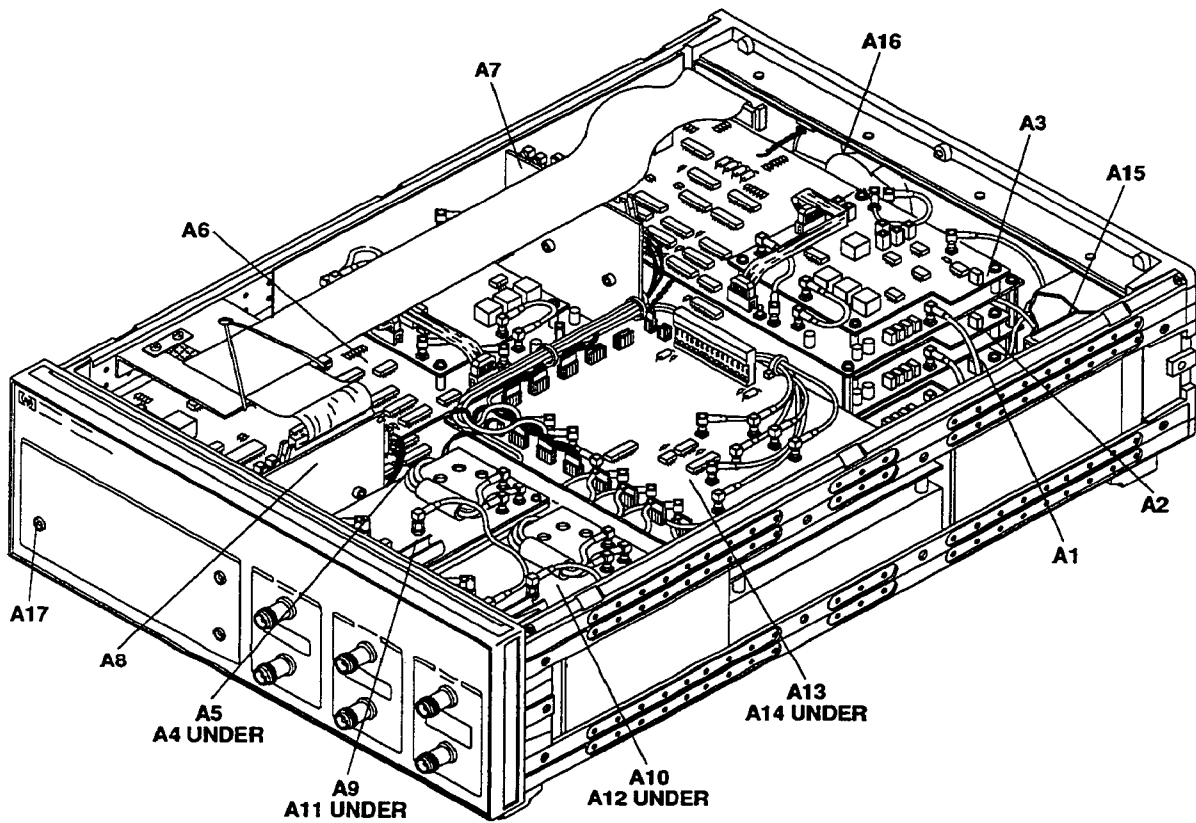

NOTE: Cables are located using the description in table 6-2 (e.g. W26 is ORN/WHT cable between A9J8 and A1J3).

Figure 6-1. Simulator Assembly Locator

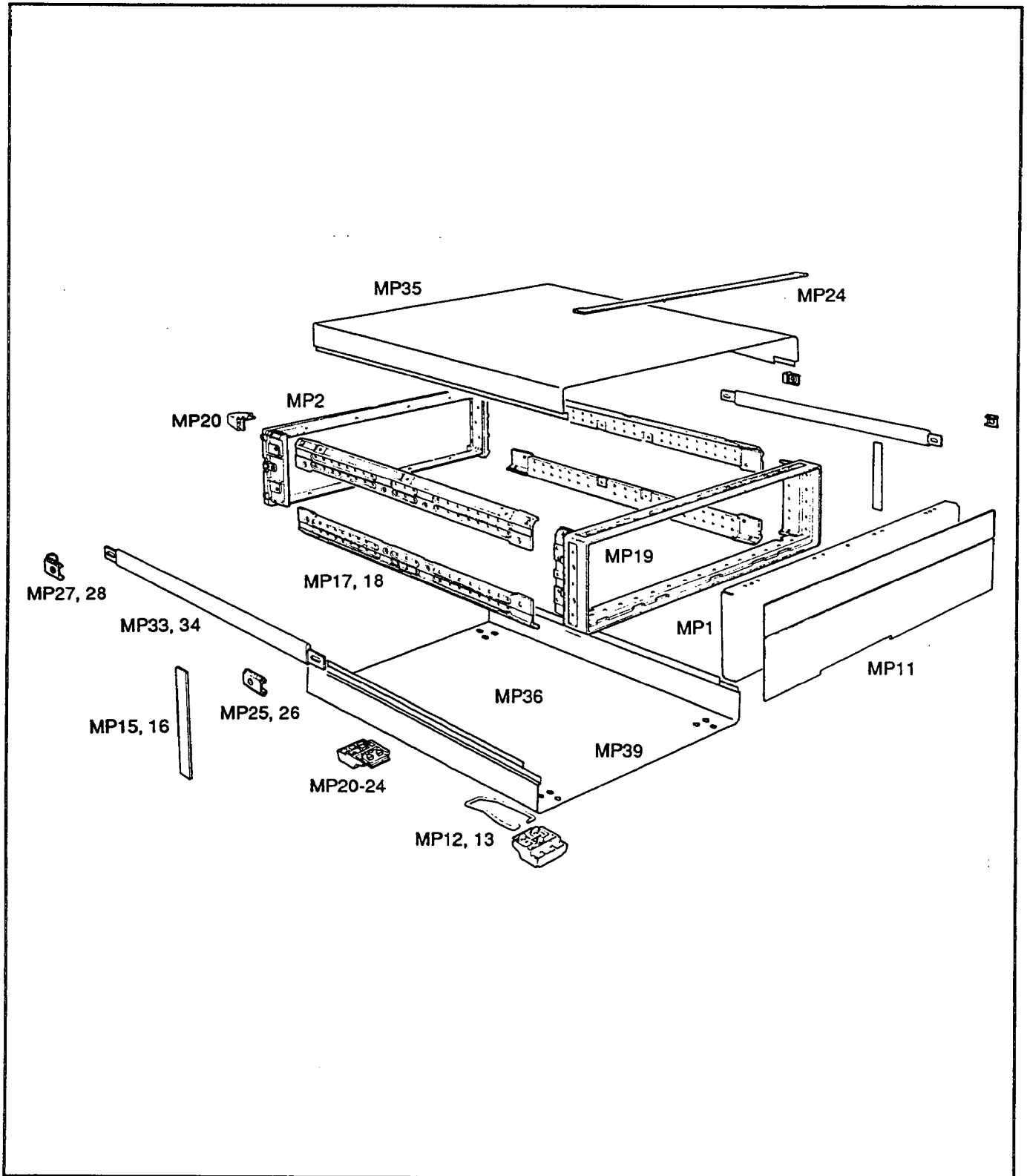

Figure 6-2. Cabinet Parts

Manual Changes

7-1. Introduction

This section normally contains information for adapting this manual to instruments for which the content does not apply directly. Since this manual does apply directly to instruments having serial numbers listed on the title page, no change information is given here. Refer to INSTRUCTIONS COVERED BY MANUAL in chapter 1 for additional important information about serial number coverage.

Service

8-1. Introduction

This chapter provides information on service related subjects. Safety considerations include warnings to be observed while servicing the instrument. The arrangement of the principles of operation, troubleshooting, and repair procedures are explained.

8-2. Safety Considerations

Before Applying Power

Verify that the instrument is set to match the available line voltage and that the correct fuse is installed. An uninterrupted safety earth ground must be provided from the main power source to the instrument input wiring terminals, power cable, or supplied power cable set.

Warnings and Cautions

Pay attention to WARNINGS and CAUTIONS. They must be followed for your protection and to avoid damage to the equipment.

Warning



Maintenance described herein is performed with power supplied to the instrument and with protective covers removed. Such maintenance should be performed only by service-trained personnel who are aware of the hazards involved (for example, fire and electrical shock). Where maintenance can be performed without power supplied, the power should be removed.

Any interruption of the protective (grounding) conductor (inside or outside the instrument) or disconnecting the protective earth terminal will cause a potential shock hazard that could result in personal injury. (Grounding one conductor of a two conductor outlet is not sufficient protection.) In addition, verify that a common ground exists between the unit under test and this instrument prior to energizing either unit.

Whenever it is likely that the protection has been impaired, the instrument must be made inoperative and be secured against any unintended operation.

If this instrument is to be energized via an autotransformer (for voltage reduction) make sure that the common terminal is connected to neutral (that is, the grounded side of the mains supply).

Warning

Service instructions are for use by service-trained personnel only. To avoid dangerous electric shock, do not perform any servicing unless qualified to do so.

Capacitors inside the instrument may still be charged even if the instrument has been disconnected from its source of supply.

For continued protection against fire hazard, replace the line fuse(s) only with 250V fuse(s) of the same current rating and type (for example normal blow, time delay, etc.). Do not use repaired fuse or short circuited fuseholders.

Caution

Do not disconnect or remove any carriers or boards in the instrument unless the instrument is unplugged. Some boards contain devices that can be damaged if the board is removed when the power is on. There are several components including MOS and CMOS devices that can be damaged by electrostatic discharge. Use conductive foam and grounding straps when servicing is required on sensitive components.

After Service Safety Checks

Visually inspect the interior of the instrument for any signs of abnormal internally generated heat, such as discolored printed circuit boards or components, damaged insulation, or evidence of arcing. Determine and remedy the cause of any such condition.

Using a suitable ohmmeter, check resistance from instrument enclosure to ground pin on power cable plug. The reading must be less than one ohm. Flex the power cable while making this measurement to determine whether intermittent discontinuities exist.

Check any indicated front or rear panel ground terminals that are marked, using the above procedures.

Check resistance from instrument enclosure to line and neutral (tied together) with the power switch on and the power source disconnected. The minimum acceptable resistance is two megohms. Replace any component that results in a failure.

Check line fuse to verify that a correctly rated fuse is installed.

8-3. Equipment Required

Test equipment and accessories required to repair the Simulator are listed in Table A-3. Equipment other than the recommended model can be used provided the critical specifications are satisfied.

8-4. Service Tools, Aids, and Information

Required Service Tools

Posidriv Screwdrivers

Many screws in the Simulator appear to be Phillips type, but are actually Posidriv. To avoid damage to the screw head slots, use Pozidriv screwdrivers No. 1, HP 8710-0899, or No. 2, HP 8710-0900.

Torx Screwdrivers

Some screws in the Simulator appear to be Hex type, but are not. To avoid damage to the screw heads, Torx screwdrivers must be used. HP 8710-1673 is size T-8. HP 8710-1284 is size T-10, and HP 8710-1816 is size T-15.

Hardware Characteristics

Caution



The Simulator uses a mixture of Unified National (inch) and metric screws. The metric screws are defined in Industrial Fasteners publication (IFI 500) and are identified in the replaceable parts list as M (metric). Do not use a metric screw with a Unified National nut, or a metric nut with a Unified National screw, because thread damage will result.

Assembly and Cable Locations

Assemblies are identified and illustrated in Figure 6-1. Cables are identified in Table 6-4 with the color and TO/FROM designations in the description column. Both Figure 6-1 and Table 6-4 are located in Chapter 6.

Parts and Cable Locations

For specific component descriptions and ordering information, refer to Table 6-4, Replaceable Parts, in Chapter 6. Chassis and frame parts, as well as mechanical parts (MP) and cables (W), are identified in Figures 6-1 and 6-2 in Chapter 6.

Test Points and Adjustment Locations

Most test points are indicated on the actual printed circuit assemblies.

Service Aids on Printed Circuit Boards

Service aids on printed circuit boards include test points, indicator lights, some reference designations, and HP part numbers.

Other Service Documents

Service Notes, Manual Change Supplements, and other service literature are available through Hewlett-Packard. For further information, contact your nearest Hewlett-Packard office.

8-5. Principles of Operation

The HP 11759C RF Channel Simulator is designed to simulate the fast and slow fading, time dispersion, and Doppler shifts seen in the mobile radio environment. A block diagram for the Simulator is provided in figure 8-1.

The Simulator either provides two separate RF channels each with three paths (standard and option 002), or a single channel with six independent paths (options 001 and 003). Each path has independent Rayleigh fade, delay, and Doppler/Phase shift capabilities.

- Channels are designated CHANNEL #1 (all) or CHANNEL #2 (standard and option 002 only). Operation of both channels is identical, with the exception of the rear panel LO output available on channel 1 only.
- Paths are designated PATH #1 through PATH #6. Each path is numerically assigned to a channel, where PATH #1, #2, and #3 are part of CHANNEL #1, and PATH #4, #5, and #6 are part of CHANNEL #1 (options 001 and 003) or part of CHANNEL #2 (standard and option 002).

Operation is facilitated by using a Vectra PC and the channel simulation software supplied. The desired functions are easily performed by responding to user menus displayed on the PC.

An RF Input Signal from 40 MHz to 2,700 MHz is applied to one of the RF INPUT connectors. This RF signal is mixed (by the Down Converter PCA (A9/A11)) with the LO Input Signal applied to the corresponding LO INPUT connector. The down-converted output signal of 6 MHz is then split and routed to each path.

Each path's HNS Path Assembly (A1-A6) provides signal processing of the down-converted signal. The type of processing is dependent on the Simulator mode.

- DELAY – The signal is sent to an 12 bit Analog-to-Digital converter, and the resulting digitized signal is sent to a First-In-First-Out (FIFO) RAM. The output of the FIFO is then routed to a Digital-to-Analog converter (DAC), and the resulting analog signal is filtered and amplified. The amount of delay is controlled by the WRITE and READ signals to the FIFO, controlled by the Vectra PC.
- DOPPLER SHIFT – The amplified signal is split into I and Q vectors, then mixed with 12 bit with sinusoids to provide a Doppler shifted signal.

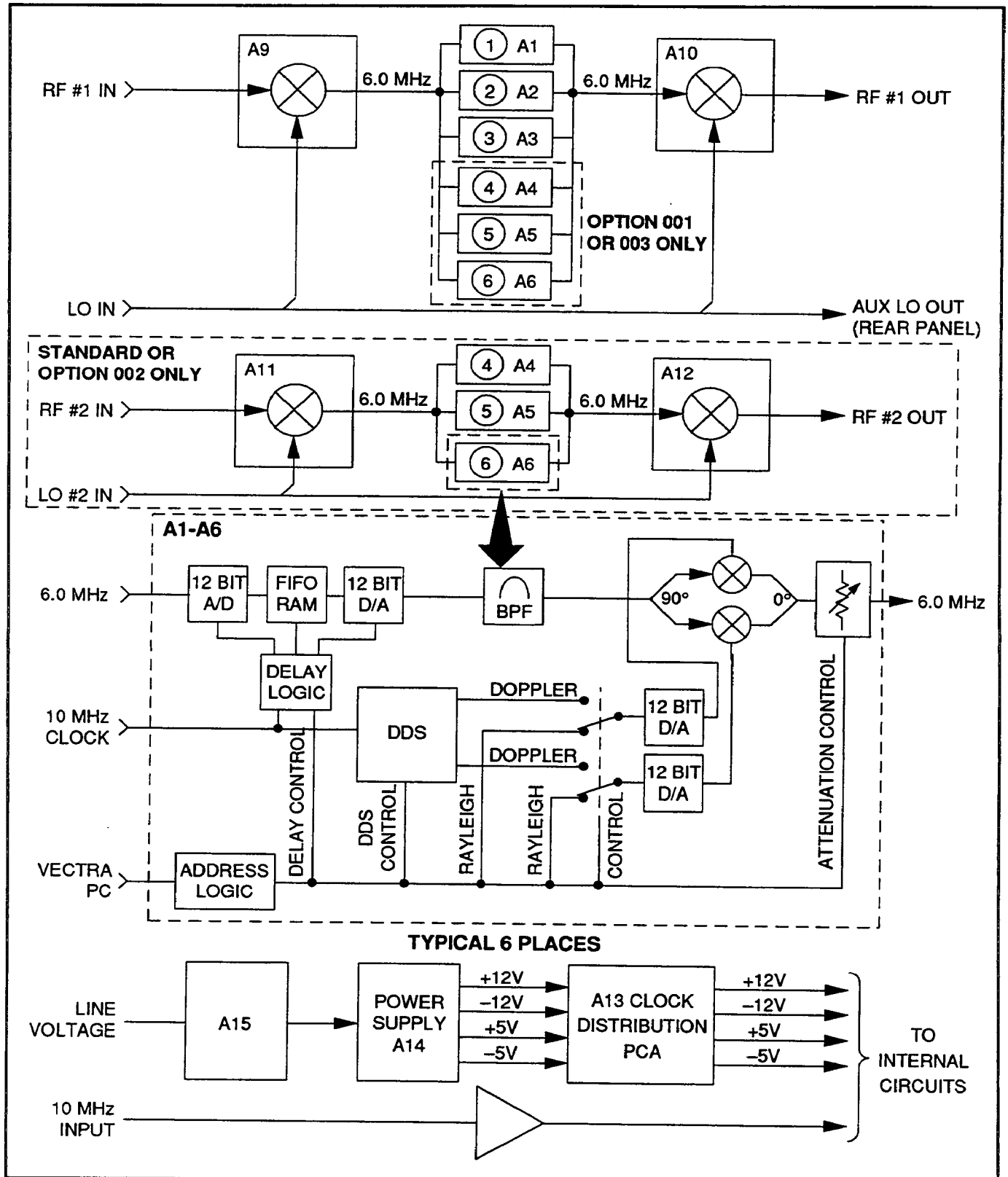

Figure 8-1. Simulator Block Diagram

- Attenuation is provided by an analog multiplier operating in a variable gain mode. The gain is controlled by a DAC, controlled by the Vectra PC.

The processed signal is combined and mixed with the same LO Input Signal on the Up Converter PCA (A10/A12). This provides an output signal at the original RF input frequency. This signal is available at the corresponding RF OUTPUT connector.

Internal power for the simulator is provided by a switching Power Supply Assembly (A14) , capable of providing over 100 watts. A14 provides +12, -12, +5 and -5 volts for Simulator operation.

The outputs from A14 are fed to the Clock/Distribution PCA (A13) for passive load regulation and distribution. The LEDs on A13 indicate the status of each power supply line. These LEDs are on when the line is active, and are off when the line is inactive.

8-6. Troubleshooting

This section will aid in troubleshooting and repair of the Simulator. It contains the necessary troubleshooting procedures for isolating a malfunction in the Simulator to the Printed Circuit Assembly level.

Refer to PRINCIPLES OF OPERATION presented earlier in this chapter (as required) for a discussion of how the Simulator functions.

The troubleshooting process contains two levels.

1. The first level is called "Determining the Failure Mode". The goal of this procedure is to determine if the Simulator has failed, and if so, what are the symptoms. This is accomplished by turning on the Simulator and checking its different features. Since certain hardware failures will exhibit multiple symptoms, this procedure is designed to determine the most significant symptoms with a minimum amount of effort. It is recommended that this procedure be followed, even if symptoms have already been identified, in order to determine the most significant symptom. This procedure does not require the Simulator's covers to be removed.

At the end of "Determining the Failure Mode" is a table that will tell you, once the most significant symptom has been identified, what the next step should be. For most symptoms, additional work needs to be done in order to determine which assembly has failed. This is accomplished in the second level, "Assembly Verification Procedures".

2. The second level in the troubleshooting process is "Assembly Verification Procedures". The purpose of these procedures is to determine if an assembly has failed and needs replacing.

Technicians with experience troubleshooting the Simulator may wish to go directly to the assembly verification procedures. These procedures require that the instrument's covers be removed.

8-7. Determining The Failure Mode

Note



Perform the following procedure in order to determine the instrument's failure mode. This is an important step even if you have already identified a failure, since hardware failures may show several symptoms.

Run the "System Verification Check" as described in chapter 2, making a note of the failures that occur. From this list of failures refer to table 8-1, Troubleshooting Guide. From the list of symptoms, determine the most probable cause and to proceed to the verify operations.

Table 8-1. Troubleshooting Guide

| Symptom | Possible cause | Corrective Action |
|---|--|---|
| Fan and or LED not working, no systems functions | A14 Power Supply | Verify Power Supply |
| Fan and or LED not working, system functions normal | A1 thru A13 contain short A16 Fan Assembly | Replace |
| Clicking sounds from inside but no functions | Power LED | Replace |
| Bad Power Out, Attenuation, Delay or Doppler from a SINGLE path | Bad Power Supply | Verify Power Supply |
| Bad outputs from all 6 paths | Bad voltages internally Bad A1-A6 Path Assembly | Verify Power Supply Verify Path Assembly |
| | Improper system install | Refer to Chapter 2 |
| | Improper operation | Refer to Chapter 3 |
| | Bad PC Interface | Verify PC Interface |
| | Bad clocks | Verify Clock/Divider |
| | Bad supply voltages | Verify Power Supply |
| Incorrect Doppler shift, and/or Delay | Bad clocks | Verify Clock/Divider |
| Bad outputs a SINGLE channel | Bad A1-A6 Path Assembly | Verify Path Assembly |
| | A9/A11 Down Converter | Verify Down Converter |
| | A10/A12 Up Converter | Verify Up Converter |
| | A7/A8 Synchronizer PCA | Verify Synchronizer |
| Bad Overdrive LED | A7/A8 Synchronizer PCA | Verify Synchronizer |
| | Bad A1-A6 Path Assembly | Verify Path Assembly |
| | Overdrive LED | Replace |

8-8. Assembly Verification Procedures

These procedures are used to further isolate suspected malfunctions to an individual assembly. The following procedures are provided:

- Verify Path – A1 through A6 Path PCAs
- Verify Synchronizer – A7 and A8 Synchronizer PCAs
- Verify Down Converter – A9 and A11 Down Converter PCAs
- Verify Up Converter – A10 and A12 Up Converter PCAs
- Verify Clock/Divider – A13 Clock/Divider PCA
- Verify Power Supply – A14 Power Supply Assembly

Verify Path

This procedure is used to verify proper operation of the A1 through A6 Path Assemblies.

1. Connect an RF Signal at 900 MHz, approximately -10 dBm to the RF INPUT connector of the suspect channel.
2. Connect an LO Signal at 894 MHz, $+10$ dBm to the LO INPUT connector of the suspect channel.
3. Turn on the faulty path by selecting desired path delay using the Channel Simulation test (refer to Chapter 3).
4. Verify supply voltages of $+5$ Vdc, -5 Vdc, -12 Vdc, and $+12$ Vdc voltages are present on the suspect Path Assembly.
 - If the voltage(s) are not present, suspect input cable (at Path Assembly J6) or the A13 Clock/Divider PCA.
 - If the voltage(s) are present, proceed with step 5.
5. Remove the cable from J2 of the suspect Path Assembly. Verify the signal out of the connector is 6 MHz.
 - If there is a signal at -12 dBm, then suspect the output cable or the corresponding Up Converter PCA.
 - If no signal is present, reinstall cable and proceed with step 6.
6. Disconnect the cable from J3 of the suspect Path Assembly. Verify a 6 MHz signal at approximately -30 dBm at the cable.
 - If no signal is present then suspect the input cable or the corresponding Down Converter PCA.
 - If signal is present, reinstall cable and proceed with step 7.
7. Remove the cable from J4 of the suspect Path Assembly. Verify this cable has a 10 MHz clock signal.
 - If the signal is not present, suspect the cable or the A13 Clock/Divider PCA.
 - If the signal is present, reinstall the cable and proceed with step 8.
8. Remove the cable from J7 of the suspect Path Assembly. Verify this cable has a 16.7 kHz clock signal.

- If the signal is not present, suspect the cable or the A13 Clock/Divider PCA.
 - If the signal is present, reinstall the cable and proceed with step 9.
9. Set Simulator POWER SWITCH to OFF. Replace the cables in the original factory installed positions. Remove W48, W49, and W50 from Synchronizer PCAs A7 and A8. Physically swap assemblies A7 and A8 (see Repair instructions later in this Chapter), then reconnect cables.
 10. Set Simulator POWER SWITCH to ON, and verify operations of the suspect path.
 - If the path now functions normal, then replace the defective A7 or A8 Synchronizer PCA.
 - If the path still malfunctions, replace the defective Path Assembly.

Verify Synchronizer

This procedure is used to verify proper operation of the A7 and A8 Synchronizer Printed Circuit Assemblies.

Note



The bottom connector on the A7/A8 Synchronizer Printed Circuit Assemblies **MUST** be connected to a powered up Path assembly to function properly and provide the 10 MHz signal at J7 from the Clock/Divider.

1. Set Simulator POWER SWITCH to OFF. Remove W48, W49, and W50 from Synchronizer PCAs A7 and A8. Swap location of assemblies A7 and A8, then reconnect cables.
2. Set Simulator POWER SWITCH to ON, and verify operations of the suspect channel.
 - If the channel now functions okay, then replace the defective A7 or A8 Synchronizer PCA.

Verify Down Converter

This procedure is used to verify proper operation of the A9 and A11 Down Converter Printed Circuit Assemblies.

Note



Simulator must be turned on to supply power to the Down Converters during verification.

1. Connect an RF Signal at 900 MHz, 0 dBm to the RF INPUT connector of the suspect channel.
2. Connect an LO Signal at 896.6 MHz, +10 dBm to the LO INPUT connector of the suspect channel.
3. Using a BNC to SMC connector, verify the down-converted 6 MHz signal at J7 of the suspect Down Converter PCA is approximately -30 dBm.

- If the signal is present, suspect output cabling connected to J8, J9, & J10.
- If no signal is present, verify that the input cables from the front panel are not faulty. Also, check for +12 Vdc at the power input feedthru. If both check OK, replace the Down Converter assembly.

Verify Up Converter

This procedure is used to verify proper operation of the A10 and A12 Up Converter Printed Circuit Assemblies.

Note



Simulator must be turned on to supply power to the Up Converters during verification.

1. Connect a LO Signal at 894 MHz, +10 dBm to the LO INPUT connector of the suspect channel.
 2. Connect a 6 MHz -12 dBm signal to the suspect Up Converter PCA at J8.
 3. Verify the up-converted 900 MHz signal is present at the suspect channel RF OUTPUT connector.
- If the signal is present, suspect input cabling connected to J8, J9, & J10.
 - If no signal is present, verify that the output cable to the front panel is not faulty. If correct, replace the Up Converter assembly.

Verify Clock/Divider

This procedure is used to verify proper operation of the A13 Clock/Divider Printed Circuit Assembly.

Note



Simulator must be turned on to supply power to the Clock/Divider during verification.

1. Verify the proper operating voltages are being output from the Clock/Divider PCA. Test points are located on the A13 PCA.

| | |
|---------------|------------|
| +12 Vdc | ±0.024 Vdc |
| +5 Vdc | ±0.01 Vdc |
| -5 Vdc | ±0.01 Vdc |
| -12 Vdc | ±0.024 Vdc |

 - If the voltages are incorrect, perform "Verify Power Supply" procedure in this chapter.
 - If the voltages are correct, but there is a problem with an assembly receiving the voltages, proceed with step 2.
 - If the voltages are correct, the supply voltages portion of the A13 PCA is functioning properly. Proceed with step 3 to verify A13 clock signals.
2. Remove the power supply cable for that assembly from the A13 PCA. Check the voltages on the A13 connector (all voltages measured to ground), using the following pin out diagram.

Printed Circuit Assembly

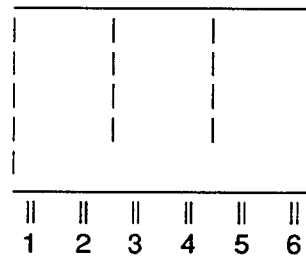

- Pin 1+5 Vdc
- Pin 2+12 Vdc
- Pin 3-12 Vdc
- Pin 4-5 Vdc
- Pin 5+5 Vdc
- Pin 6Ground

- If the pin voltages are incorrect, then check A13 for burnt traces or shorts. Replace if necessary.
- If the pin voltages are correct, suspect cabling.

3. Connect a 10 MHz External Timebase signal (0 to +20 dBm) to the TIMEBASE INPUT connector. Verify the timebase input signal is present at A13U1 pin 2.

- If incorrect, suspect input cabling.

4. Verify the following TTL Level signals:

- A13 U1 pin 6 10 MHz squarewave clock
- A13J2 16.7 kHz clock
- A13J3 16.7 kHz clock
- A13J4 16.7 kHz clock
- A13J5 16.7 kHz clock
- A13J6 16.7 kHz clock
- A13J7 16.7 kHz clock
- A13J8 10 MHz squarewave clock
- A13J9 10 MHz squarewave clock
- A13J10 10 MHz squarewave clock
- A13J11 10 MHz squarewave clock
- A13J12 10 MHz squarewave clock
- A13J13 10 MHz squarewave clock

- If any signals are incorrect, replace the A13 Clock/Divider PCA.

Verify Power Supply

This procedure is used to verify proper operation of the A14 Power Supply Assembly.

1. Verify that the line voltage selection is correct for the input line voltage. Check the fuse for continuity and replace it if necessary. Refer to Figure 2-1 for more information.
2. If none of the LEDs light and no operating noises are heard, then it is possible that the line module is faulty. Disconnect W41 from the power supply. Check the AC voltages with the POWER SWITCH set to ON. The grey wire is the hot line, and should measure approximately 120 Vac (or approximately 240 Vac).

- If nothing is measured, replace the A15 Line Filter Assembly.
 - If the voltage is correct, replace the A14 Power Supply Assembly.
3. If there is a clicking sound originating from the power supply and the LEDs are off, then remove the power distribution connections A13J15 thru A13J25 (W15 thru W25), LED, and Fan cables one at a time. If upon removing a connection the LEDs come on, then there is a problem with the assembly attached to that cable.

Note



In order to keep power supplies regulated, a minimum of 4 Path PCAs must be connected at all times.

- If this hasn't found the problem, replace the A14 Power Supply Assembly.
4. If the LEDs light up, then most likely the A14 Power Supply is functioning correctly. However, it still should be checked for tolerance. The tolerances for the supply are given below. Test points are located on the A13 Clock/Divider PCA for all the supply lines.

| | |
|---------------|------------|
| +12 Vdc | ±0.024 Vdc |
| +5 Vdc | ±0.01 Vdc |
| -5 Vdc | ±0.01 Vdc |
| -12 Vdc | ±0.024 Vdc |

Verify Overdrive LED

This procedure verifies proper operation of the Overdrive LED(s).

1. Press CNTL-BACKSPACE and verify Overdrive LED's blink.
 - If incorrect, perform the Verify Synchronizer test. If test passes, replace Overdrive LED.

Verify PC Interface

This procedure is used to verify that the interface between the Vectra PC and the HP 11759C is functioning properly.

1. Verify that the HP 11759C is installed properly (refer to Chapter 2, paragraphs 2-1 through 2-5).
2. Reset the HP 11759C by pressing the "CTRL-BACKSPACE" keys, then select the Simulator test. Set PATH #3 SPECTRUM to Doppler.
3. Verify the voltage at A1A1TP5 is approximately 10 Vdc.
4. Set PATH #3 ATTENUATION to 50dB.
5. Verify the voltage at A1A1TP5 is now +28 mVdc.
 - If correct, the PC interface is functioning.

8-9. Repair

Repair of the Simulator consists of removing the defective assembly, then reinstalling a new replacement assembly. After completing repairs to the Simulator, the System verification Checks in Chapter 2 should be completed to ensure that the instrument is operating correctly.

Warning



Before beginning any disassembly procedure, be sure that the line (Mains) voltage is disconnected. Voltages exist that can cause personal injury.

Electrostatic Discharge (ESD) Precautions



Electrostatic discharge (ESD) can cause damage to certain devices in the Simulator, ranging from slight parameter degradation to complete failure.

MOS, CMOS, and other static sensitive devices are used in this instrument. They are prone to damage from both static electricity and transient signals. They must be handled carefully. When working on the Simulator, keep in mind the following recommendations to avoid damaging these sensitive components.

1. Use a static-free work station with a pad of conductive rubber or similar material.
2. Do not remove any board unless the Simulator has been unplugged.
3. After removing boards from the Simulator, be sure that they are placed on a conductive surface to guard against ESD damage. Do not stack boards.
4. When replacing a MOS or CMOS device, ground the foam on which it resides to the instrument before removing it. If a device requires soldering, make sure that the assembly is lying on a pad of conductive material, and that the pad, soldering iron tip, and personnel, are grounded to the assembly. Apply as little heat as possible.

This procedure is used to remove the Simulators top cover.

1. Remove the two plastic standoffs at the rear of the instrument.
2. Remove the two pozi-drive screws holding the front and rear caps on either end of the handle straps on both sides of the instrument. Remove the caps and handle straps.
3. Unscrew the 18 Torx screws all along either side of the instrument. These screws hold the top and bottom "clam-shell" covers together, with the top cover fitting over the lipped edge of the bottom cover.

4. Unscrew the Torx screw at the middle of the rear edge of the cover. This is a captive screw and will cause the top cover to move away from the frame.
5. The top cover must be removed first, by sliding it away from the front and lifting the side edges up and over the edge of the bottom cover.

Bottom Cover

1. For better access to the bottom of the instrument, the unit must be turned over to remove the bottom cover.
2. Remove the two plastic standoffs at the rear of the instrument, and the four feet on the bottom of the instrument.
3. Unscrew the captive Torx screw at the middle of the rear edge of the cover.
4. Remove the bottom cover by sliding it away from the front of the instrument.

Cover Replacement

1. To replace the covers, position the bottom cover first, and then slide the top cover into place, making sure it overlaps the bottom cover and fits into the slot provided on the top of the instrument.
2. Engage the captive Torx screw for the top cover first and tighten, then engage the captive screw for the bottom cover in the same manner.
3. Engage the 18 Torx screws on both sides and tighten.
4. Replace plastic standoffs, feet, handles and endcaps.

Note



Assemblies A1-A3 and A4-A6 are stacked in reverse order respectively. This requires that the Assemblies be removed in the following order: A3, A2, A1, and A6, A5, A4 with Assemblies A1 and A4 being on the bottom.

It is also necessary to remove Assemblies A7/A8 prior to the removal of Assemblies A1-A6, so this procedure will be discussed first.

**A7/A8 Synchronizer
PCA**

This procedure is used to remove the A7 or A8 Synchronizer Printed Circuit Assemblies. Figure 8-2 illustrates the parts.

1. Remove the top cover (instructions are provided earlier in this chapter).
2. Disconnect the shielded Centronics ribbon cable as follows:
 - Remove the two cable ties securing the Centronics cable to the cable bracket attached to the side of the unit.
 - Remove the screw connecting the metal grounding braid at the corner bend in the cable to the side panel of the instrument.
 - Remove the two screws holding down the bracket over the metal grounding braid at the corner bend in the cable.
3. Disconnect the following cables:
 - LED Cablesfrom A7/A8
 - W50 (WHT)from A8 (if removing A8)
 - W49 (WHT)from A7 (if removing A7)
4. Remove four hex screws (two on each board) holding PCA to Path PCAs.
5. Disconnect W48 from the Synchronizer PCA.
6. Being careful to avoid the cable bracket, pull-out-and-up, and remove the Synchronizer PCA.
7. Reverse order to replace the A6 Path Assembly.

Caution



Use caution when separating W48 from the A7 and A8 assemblies. Do not pull up on the ribbon cable, as it may cause the connectors on W48 to come apart. Correct procedure is to pry up directly on the connectors or use ejector handles if so equipped.

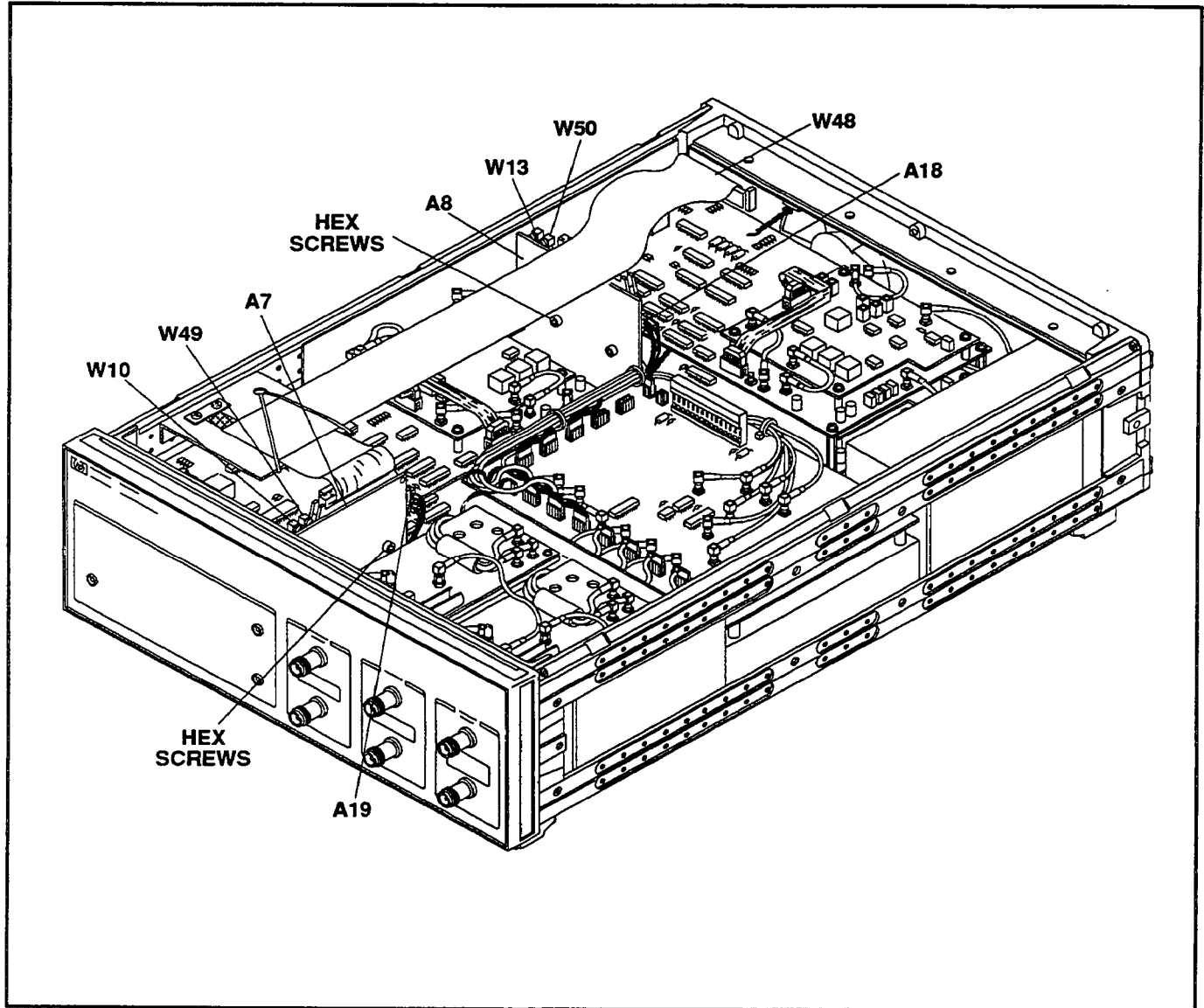

Figure 8-2. A7 and A8 Synchronizer PCA Remove and Replace

A3 Path Assembly

This procedure is used to remove the A3 Path Assembly. Figure 8-3 illustrates the parts.

1. Remove the top cover (instructions are provided earlier in this chapter).
2. Remove A8 Synchronizer PCA (instructions are provided earlier in this chapter).
3. Disconnect the following cables:

| | |
|---------------------|-----------|
| W32 (GRN) | from A3J2 |
| W28 (ORN/WHT) | from A3J3 |
| W49 (WHT) | from A3J4 |
| W21 | from A3J6 |
| W7 (GRY/ORN) | from A3J7 |
4. Remove the five Torx screws and lockwashers.
5. Disconnect the grounding lug between the upper right corner of the A3 Path Assembly and the threaded standoff below.
6. Disconnect the A3 PCA from the A8 Synchronizer PCA and remove.
7. Reverse order to replace the A3 Path Assembly.

Note



Verify the jumper (HP P/N 1258-0209) is installed in position W3 (as shown on figure 8-3) before installing the A3 PCA.

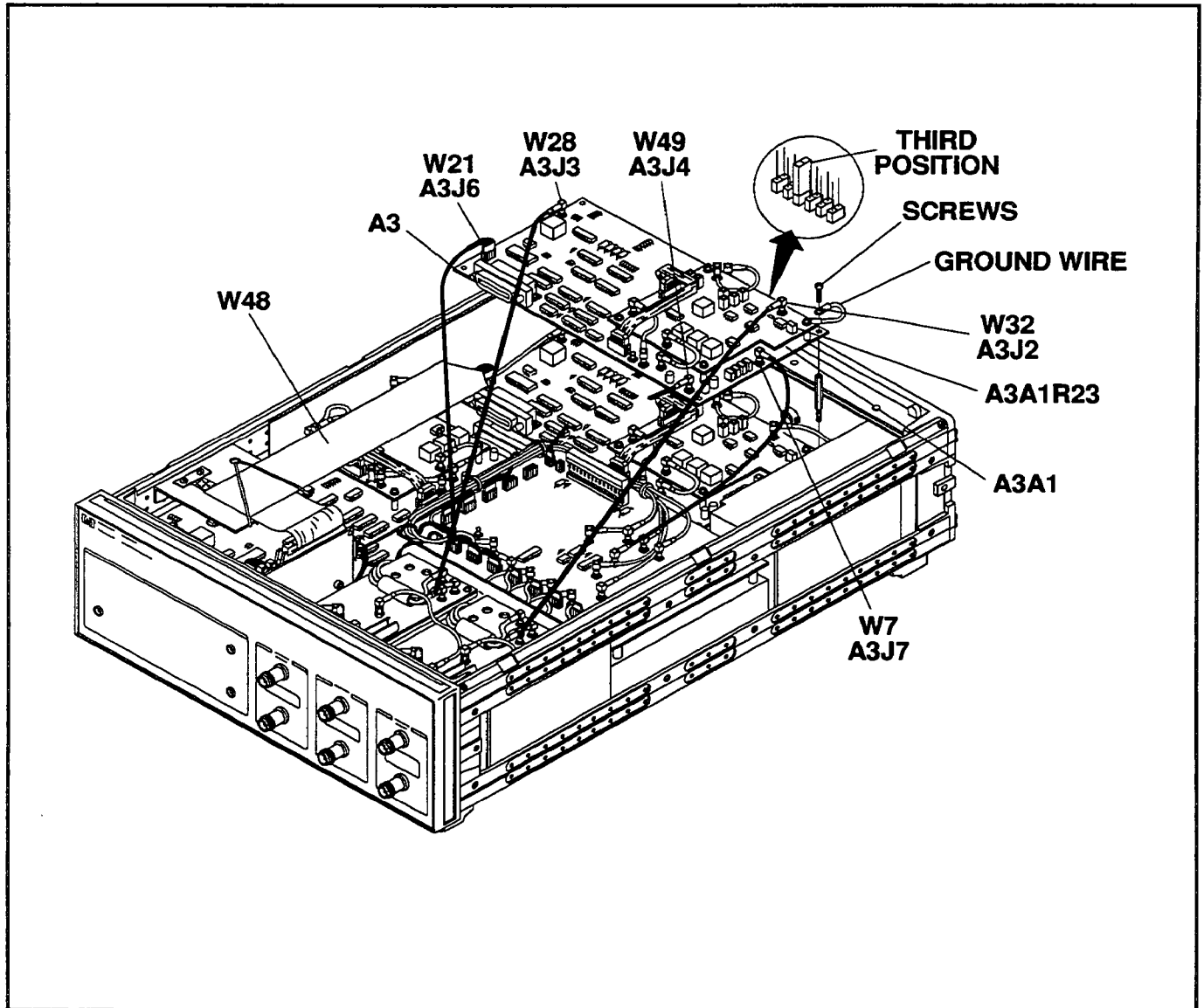

Figure 8-3. A3 Path Assembly Remove and Replace

A2 Path Assembly

This procedure is used to remove the A2 Path Assembly. Figure 8-4 illustrates the parts.

1. Remove the top cover (instructions are provided earlier in this chapter).
2. Remove the A8 Synchronizer PCA and A3 Path Assembly (instructions are provided later in this chapter).
3. Disconnect the following cables:

| | |
|---------------------|-----------|
| W31 (GRN) | from A2J2 |
| W27 (ORN/WHT) | from A2J3 |
| W12 (YEL) | from A2J4 |
| W20 | from A2J6 |
| W6 (GRY/ORN) | from A2J7 |

4. Remove the five threaded standoffs.
5. Disconnect the grounding lug between the upper right corner of the A2 Path Assembly and the threaded standoff below.
6. Disconnect the A2 PCA from the A8 Synchronizer PCA and remove.
7. Reverse order to replace the A2 Path Assembly.

Note



Verify the jumper (HP P/N 1258-0209) is installed in position W2 (as shown on figure 8-4) before installing the A2 PCA.

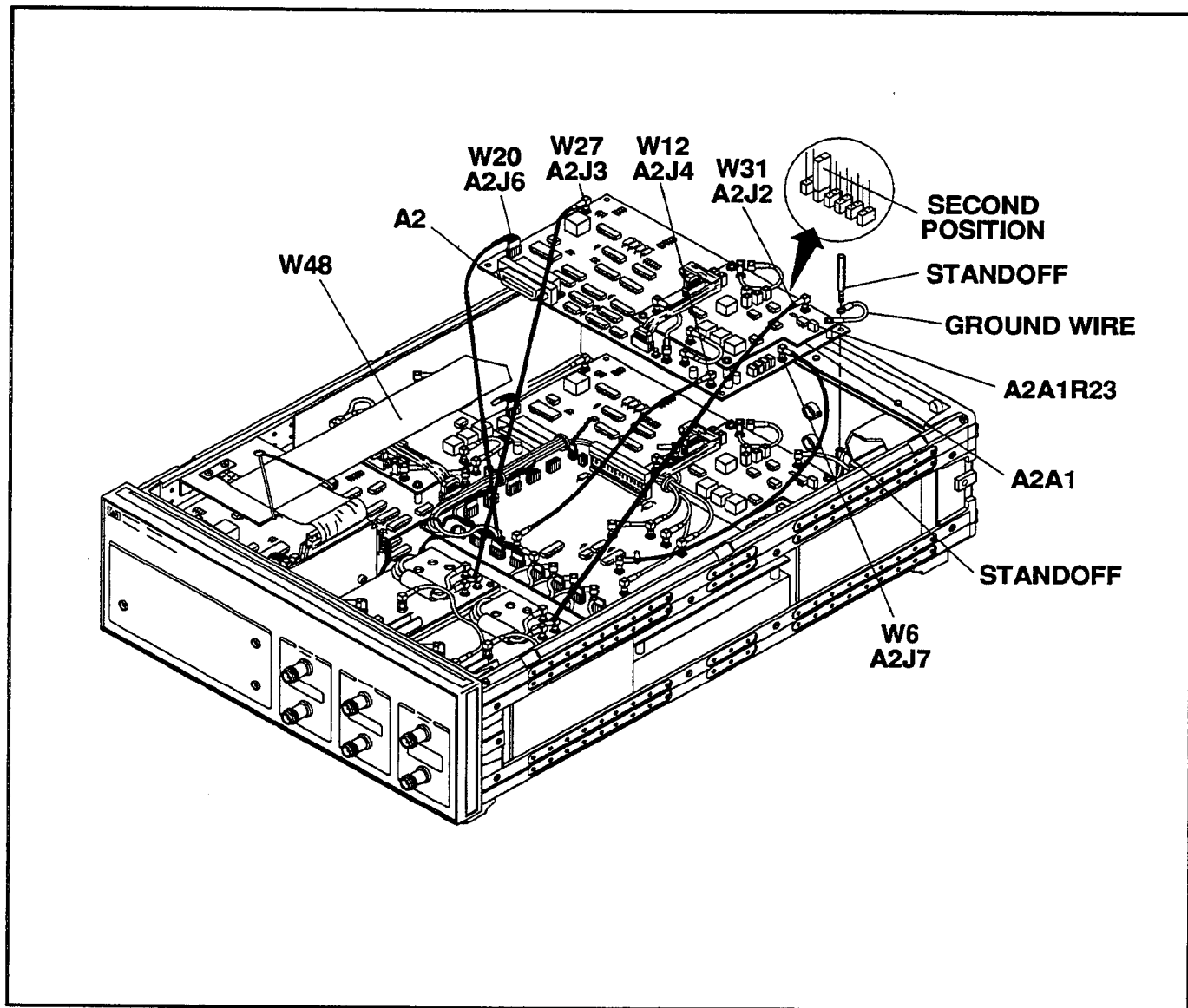

Figure 8-4. A2 Path Assembly Remove and Replace

A1 Path Assembly

This procedure is used to remove the A1 Path Assembly. Figure 8-5 illustrates the parts.

1. Remove the top cover (instructions are provided earlier in this chapter).
2. Remove the A8 Synchronizer PCA, and A2 and A3 Path PCAs (instructions are provided later in this chapter).
3. Disconnect the following cables:

| | | |
|---------------|-------|-----------|
| W30 (GRN) | | from A1J2 |
| W26 (ORN/WHT) | | from A1J3 |
| W11 (YEL) | | from A1J4 |
| W19 | | from A1J6 |
| W5 (GRY/ORN) | | from A1J7 |

4. Remove the five threaded standoffs.
5. Disconnect the grounding lug between the upper right corner of the A1 Path Assembly and the threaded standoff below.
6. Disconnect the A1 PCA from the A8 Synchronizer PCA and remove.
7. Reverse order to replace the A1 Path Assembly.

Note



Verify the jumper (HP P/N 1258-0209) is installed in position W1 (as shown on figure 8-5) before installing the A1 PCA.

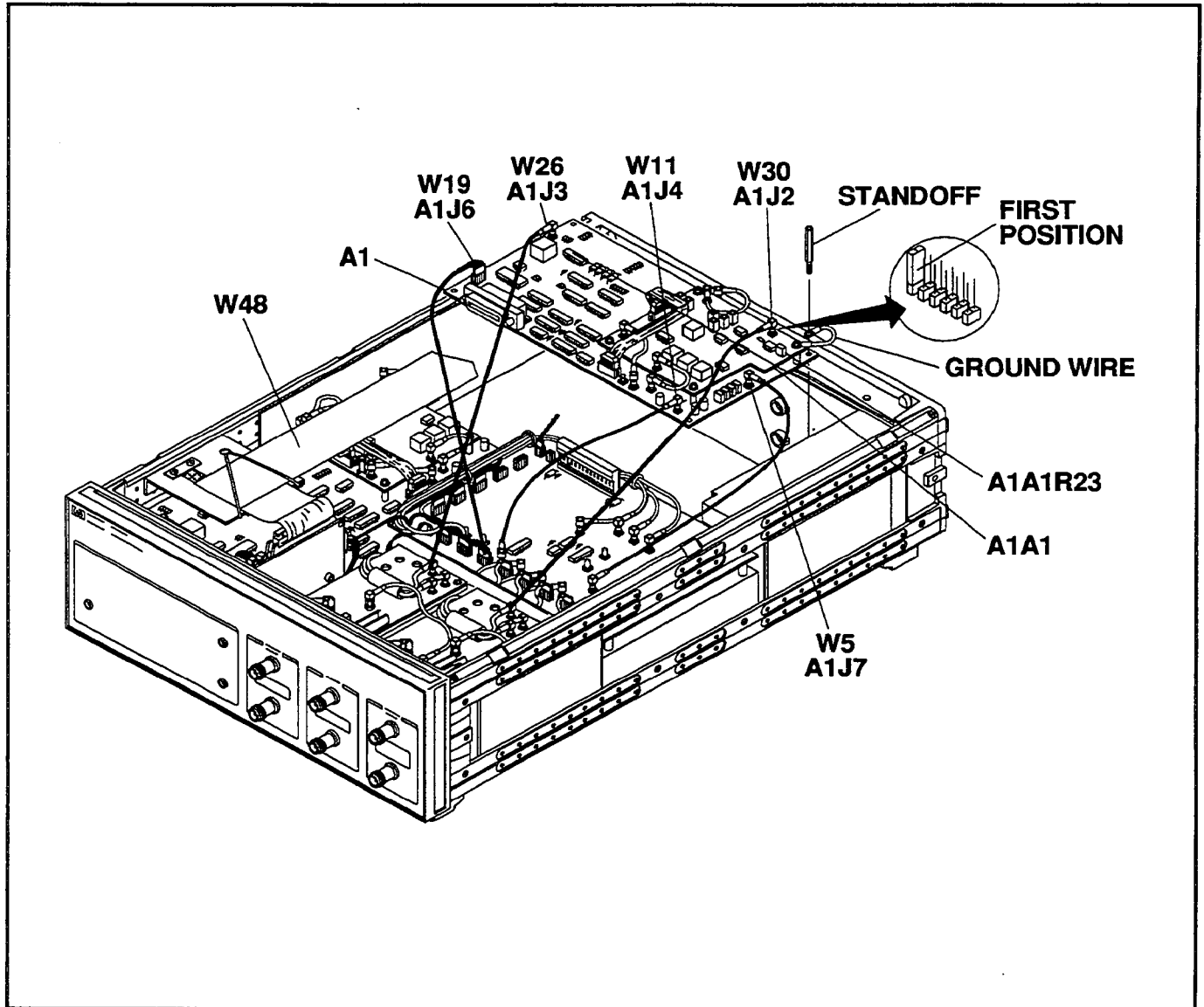

Figure 8-5. A1 Path Assembly Remove and Replace

A6 Path Assembly

This procedure is used to remove the A6 Path Assembly. Figure 8-6 illustrates the parts.

1. Remove the top cover (instructions are provided earlier in this chapter).
2. Remove A7 Synchronizer PCA (instructions are provided earlier in this chapter).
3. Disconnect the following cables:

| | | |
|---------------|-------|-----------|
| W39 (RED/GRY) | | from A6J2 |
| W35 (GRY/YEL) | | from A6J3 |
| W50 (WHT) | | from A6J4 |
| W25 | | from A6J6 |
| W2 (WHT) | | from A6J7 |
4. Remove the five Torx screws and lockwashers.
5. Disconnect the grounding lug between the upper right corner of the A6 Path Assembly and the threaded standoff below.
6. Disconnect the A6 PCA from the A7 Synchronizer PCA and remove.
7. Reverse order to replace the A6 Path Assembly.

Note



Verify the jumper (HP P/N 1258-0209) is installed in position W6 (as shown on figure 8-6) before installing the A6 PCA.

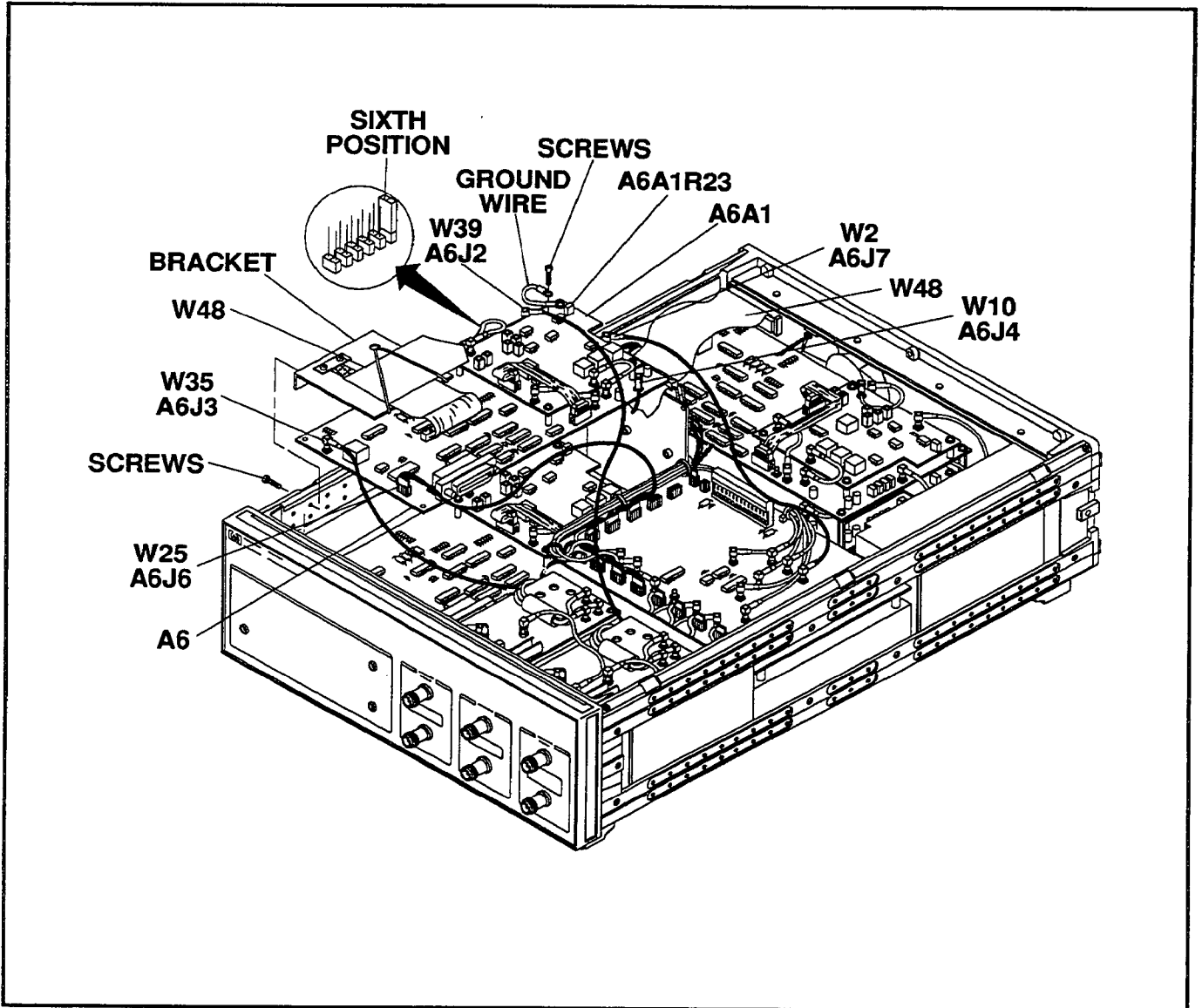

Figure 8-6. A6 Path Assembly Remove and Replace

A5 Path Assembly

This procedure is used to remove the A5 Path Assembly. Figure 8-7 illustrates the parts.

1. Remove the top cover (instructions are provided earlier in this chapter).
2. Remove the A7 I/O PCA and A6 Path Assembly (instructions are provided later in this chapter).
3. Disconnect the following cables:
 - W38 (RED/GRY) from A5J2
 - W34 (GRY/YEL) from A5J3
 - W9 (WHT/RED) from A5J4
 - W24 from A5J6
 - W3 (WHT) from A5J7
4. Remove the five threaded standoffs.
5. Disconnect the grounding lug between the upper right corner of the A5 Path Assembly and the threaded standoff below.
6. Disconnect the A5 PCA from the A7 Synchronizer PCA and remove.
7. Reverse order to replace the A5 Path Assembly.

Note



Verify the jumper (HP P/N 1258-0209) is installed in position W5 (as shown on figure 8-7) before installing the A5 PCA.

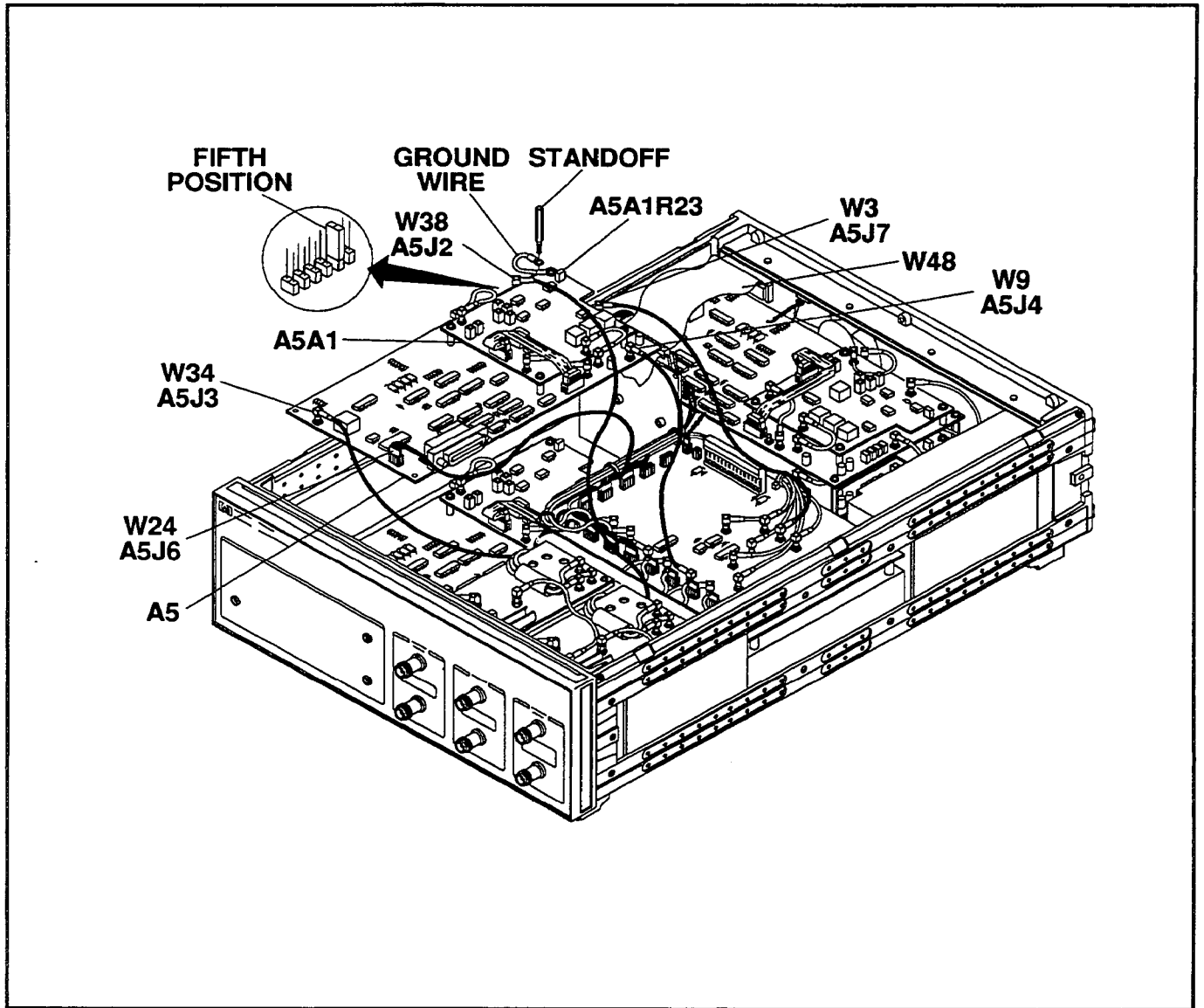

Figure 8-7. A5 Path Assembly Remove and Replace

A4 Path Assembly

This procedure is used to remove the A4 Path Assembly. Figure 8-8 illustrates the parts.

1. Remove the top cover (instructions are provided earlier in this chapter).
2. Remove the A7 Synchronizer PCA, and A5 and A6 Path PCAs (instructions are provided later in this chapter).
3. Disconnect the following cables:

| | | |
|---------------|-------|-----------|
| W37 (RED/GRY) | | from A4J2 |
| W33 (GRY/YEL) | | from A4J3 |
| W8 (WHT/RED) | | from A4J4 |
| W23 | | from A4J6 |
| W4 (WHT) | | from A4J7 |
4. Remove the five threaded standoffs.
5. Disconnect the grounding lug between the upper right corner of the A4 Path Assembly and the threaded standoff below.
6. Disconnect the A4 PCA from the A7 Synchronizer PCA and remove.
7. Reverse order to replace the A4 Path Assembly.

Note



Verify the jumper (HP P/N 1258-0209) is installed in position W4 (as shown on figure 8-8) before installing the A4 PCA.

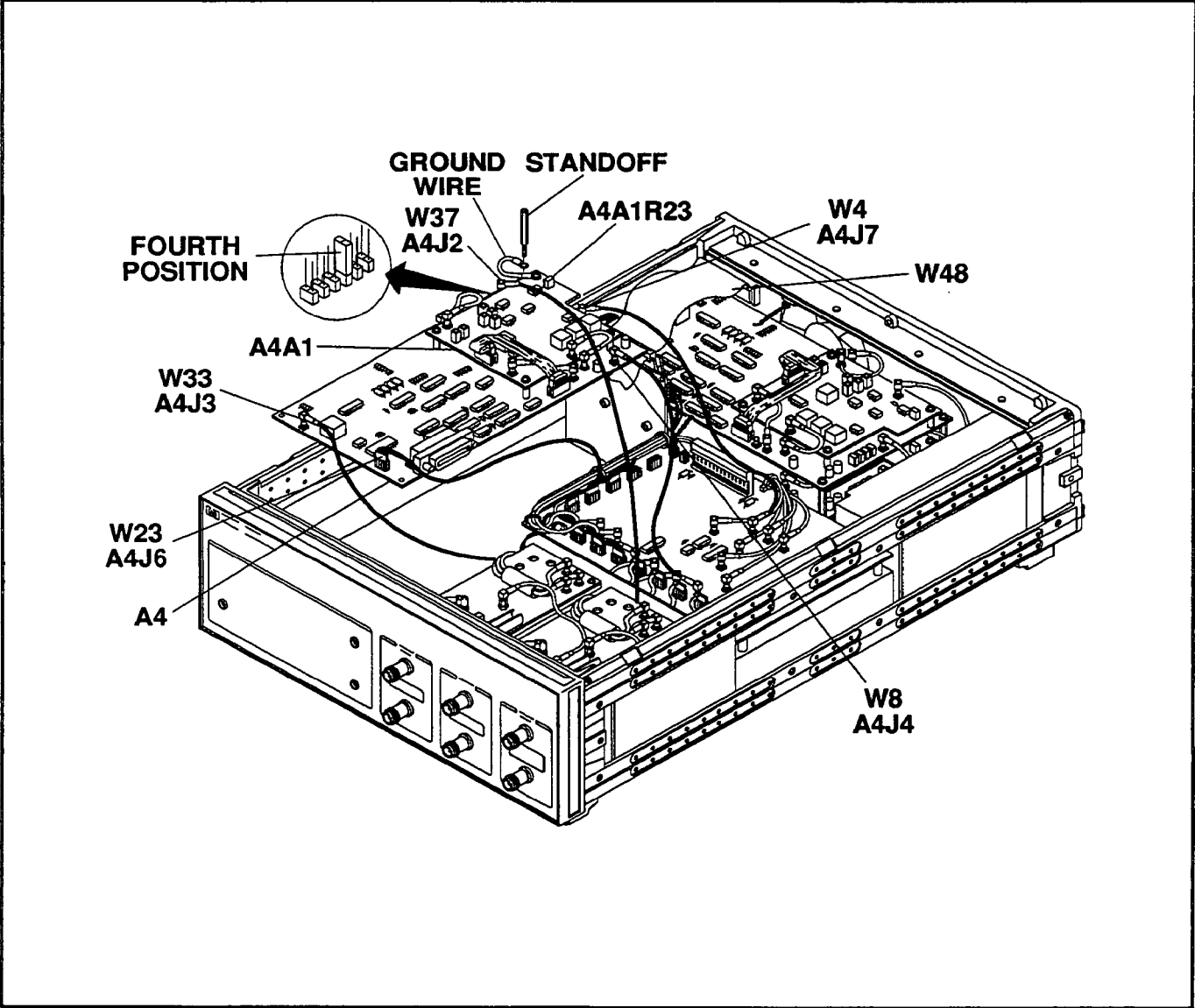

Figure 8-8. A4 Path Assembly Remove and Replace

**A9 Down Converter PCA
(STD/OPT 002)**

This procedure is used to remove the A9 Down Converter Printed Circuit Assembly. Figure 8-9 illustrates the parts.

1. Remove the top cover (instructions are provided earlier in this chapter).

2. Disconnect the following cables/terminations:

- W17 (RED) from A13J17
- W33 (BLUE) from A9J8
- W34 (BLUE) from A9J9
- W35 (BLUE) from A9J10
- W29 (BLU) from TO UP CONVERTER BLUE
- W44 (VIO) from LO INPUT FRONT PANEL
- W42 (VIO) from RF INPUT FRONT PANEL

3. Remove the four Torx screws and cover. Note that the ferrite beads can remain in the spring clamps on the top cover. Lift out the A9 Down Converter PCA.

4. Reverse order to replace the A9 Down Converter PCA.

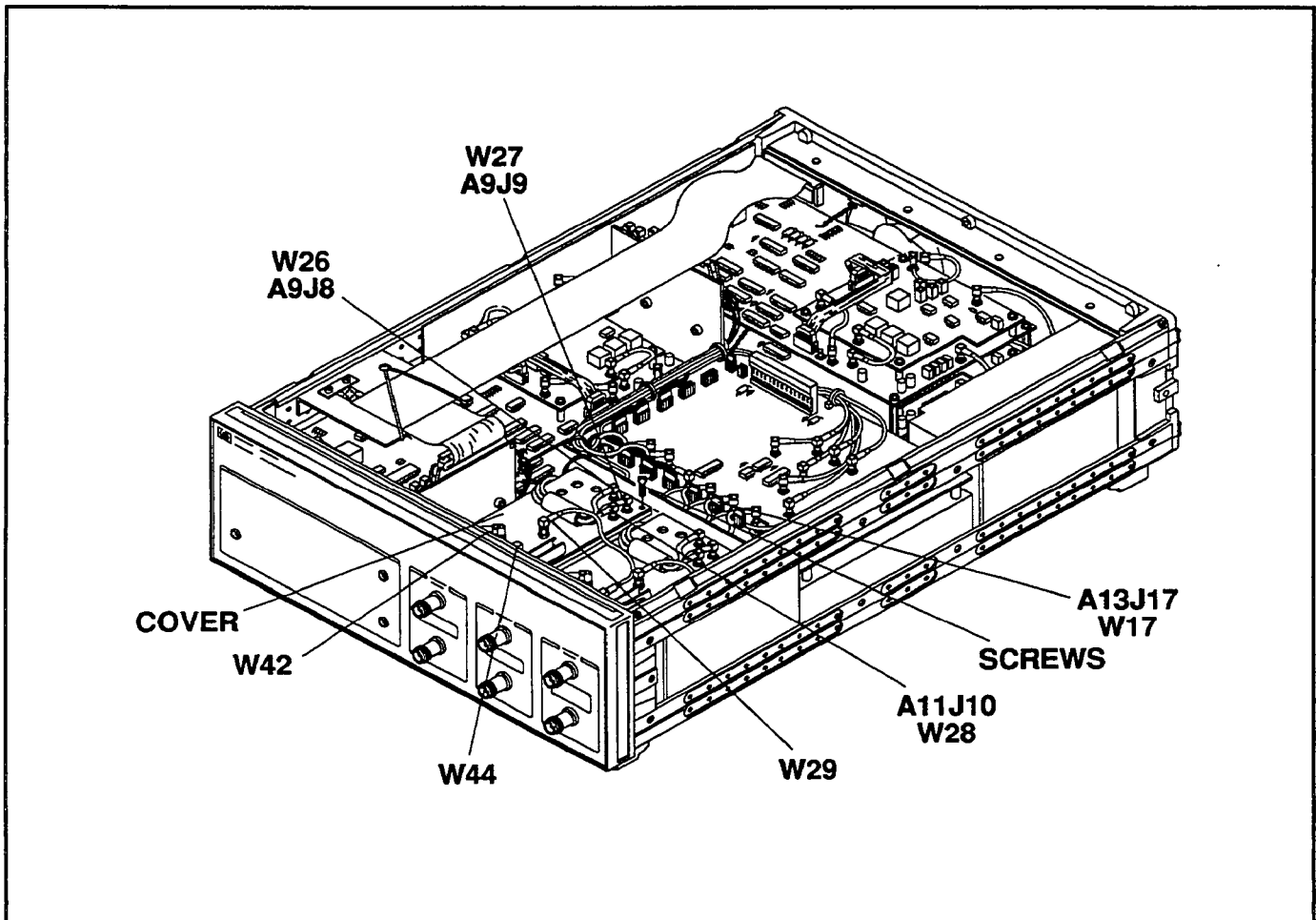

Figure 8-9. A9 Down Converter PCA Remove and Replace (STD/OPT 002)

**A10 Up Converter PCA
(STD/OPT 002)**

This procedure is used to remove the A10 Up Converter Printed Circuit Assembly. Figure 8-10 illustrates the parts.

1. Remove the top cover (instructions are provided earlier in this chapter).

2. Disconnect the following cables/terminations:

- W15 (RED)from A13J15
- W30 (YELLOW)from A10J8
- W31 (YELLOW)from A10J9
- W32 (YELLOW)from A10J10
- W29 (BLU)from TO DOWN CONVERTER BLUE
- W40 (GRY)from AUX LO OUT REAR PANEL
- W43 (VIO)from RF OUTPUT FRONT PANEL

3. Remove the four Torx screws and cover. Note that the ferrite beads can remain in the spring clamps on the top cover. Lift out the A10 Up Converter PCA.

4. Reverse order to replace the A10 Up Converter PCA.

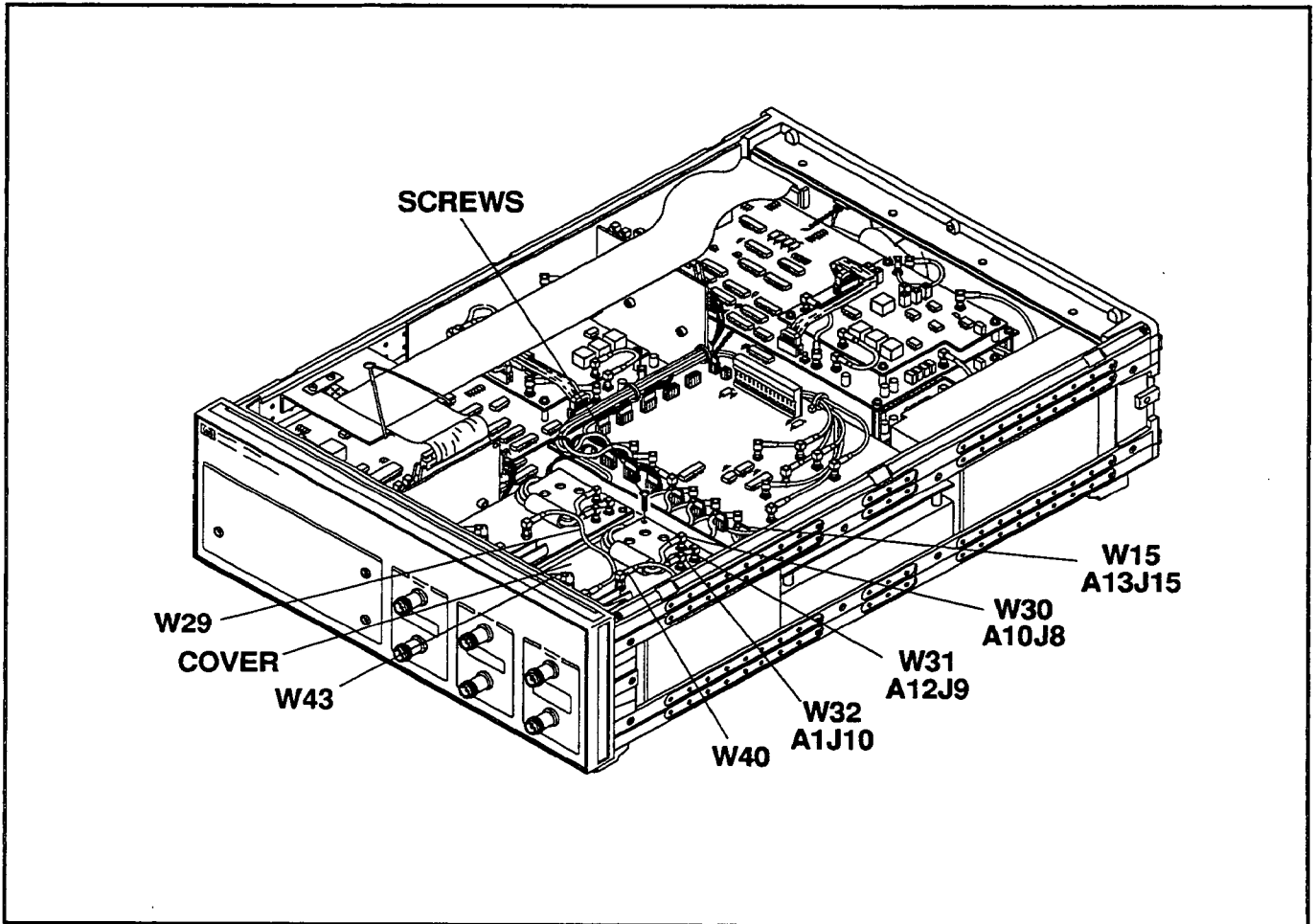

Figure 8-10. A10 Up Converter PCA Remove and Replace (STD/OPT 002)

A11 Down Converter PCA (STD/OPT 002)

This procedure is used to remove the A11 Down Converter Printed Circuit Assembly. Figure 8-11 illustrates the parts.

1. Remove the top cover (instructions are provided earlier in this chapter).
2. Remove the A9 Down Converter PCA (instructions are provided earlier in this chapter).
3. Remove the A10 Up Converter PCA (instructions are provided earlier in this chapter).
4. Remove four Torx screws and the converter deck.
5. Disconnect the following cables/terminations:

- W18 (RED)from A13J18
- W26 (GREEN)from A11J8
- W27 (GREEN)from A11J9
- W28 (GREEN)from A11J10
- W36 (BLU)from TO UP CONVERTER BLUE
- W47 (VIO)from LO INPUT FRONT PANEL
- W45 (VIO)from RF INPUT FRONT PANEL

6. Remove the four Torx screws and cover. Note that the ferrite beads can remain in the spring clamps on the top cover. Lift out the A11 Down Converter PCA.
7. Reverse order to replace the A11 Down Converter PCA.

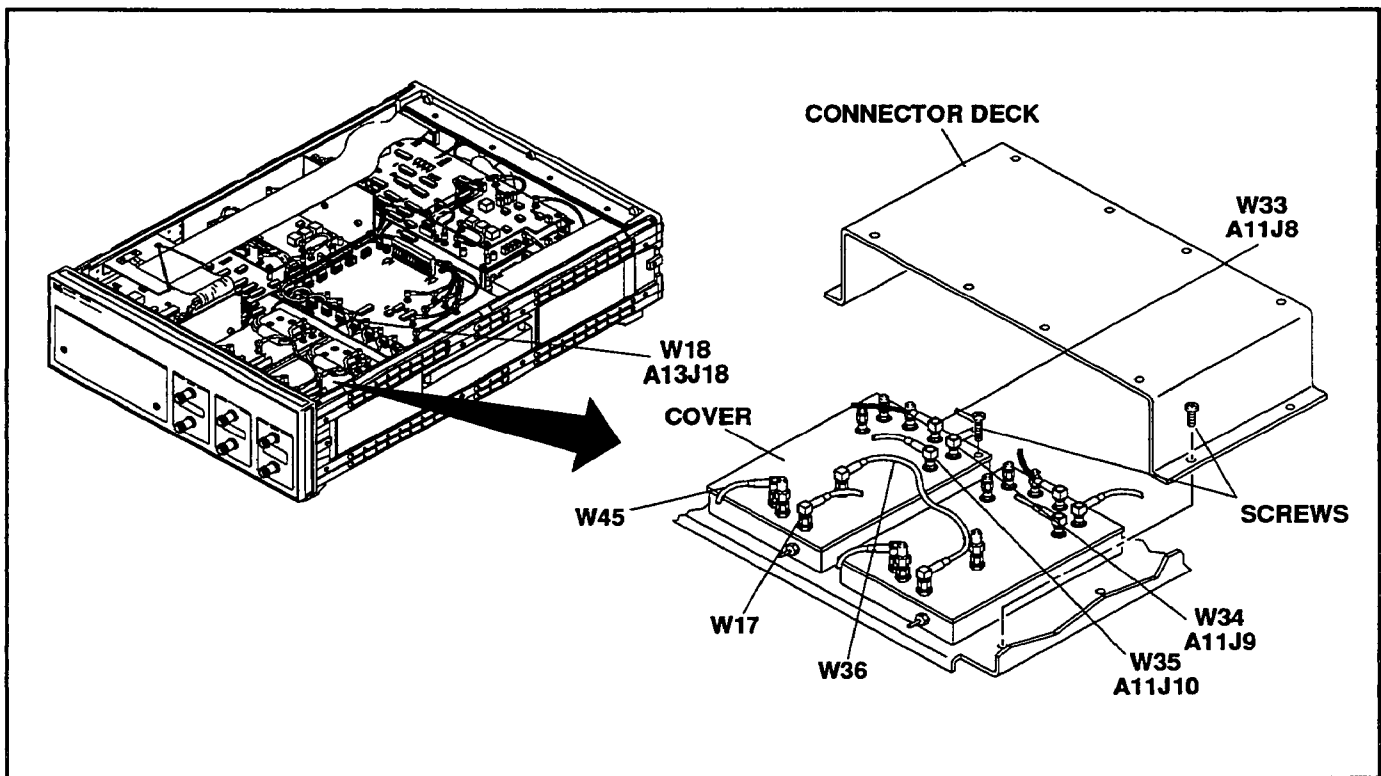

Figure 8-11. A11 Down Converter PCA Remove and Replace (STD/OPT 002)

**A11 Down Converter
PCA (OPT 001/003
ONLY)**

This procedure is used to remove the A11 Down Converter Printed Circuit Assembly. Figure 8-12 illustrates the parts.

1. Remove the top cover (instructions are provided earlier in this chapter).
2. Disconnect the following cables/terminations:
 - W17 (RED)from A13J17
 - W33 (BLUE)from A11J5
 - W34 (BLUE)from A11J6
 - W35 (BLUE)from A11J7
 - W26 (GREEN)from A11J8
 - W27 (GREEN)from A11J9
 - W28 (GREEN)from A11J10
 - W29 (BLU)from TO UP CONVERTER BLUE
 - W44 (VIO) from LO INPUT FRONT PANEL
 - W42 (VIO)from RF INPUT FRONT PANEL
3. Remove the four Torx screws and cover. Note that the ferrite beads can remain in the spring clamps on the top cover. Lift out the A11 Down Converter PCA.
4. Reverse order to replace the A11 Down Converter PCA.



Figure 8-12. A11 Down Converter PCA Remove and Replace (OPT 001/003 ONLY)

**A12 Up Converter PCA
(STD/OPT 002)**

This procedure is used to remove the A12 Up Converter Printed Circuit Assembly. Figure 8-13 illustrates the parts.

1. Remove the top cover (instructions are provided earlier in this chapter).
2. Remove the A9 Down Converter PCA (instructions are provided earlier in this chapter).
3. Remove the A10 Up Converter PCA (instructions are provided earlier in this chapter).
4. Remove four Torx screws and the converter deck.
5. Disconnect the following cables/terminations:

- W16 (RED)from A13J16
- W37 (VIOLET)from A12J8
- W38 (VIOLET)from A12J9
- W39 (VIOLET)from A12J10
- W36 (BLU)from TO DOWN CONVERTER BLUE
50Ω TERM (HP P/N 1250-0839) ...from AUX LO OUT REAR
PANEL
- W46 (VIO)from RF OUTPUT FRONT PANEL

6. Remove the four Torx screws and cover. Note that the ferrite beads can remain in the spring clamps on the top cover. Lift out the A12 Up Converter PCA.
7. Reverse order to replace the A12 Up Converter PCA.

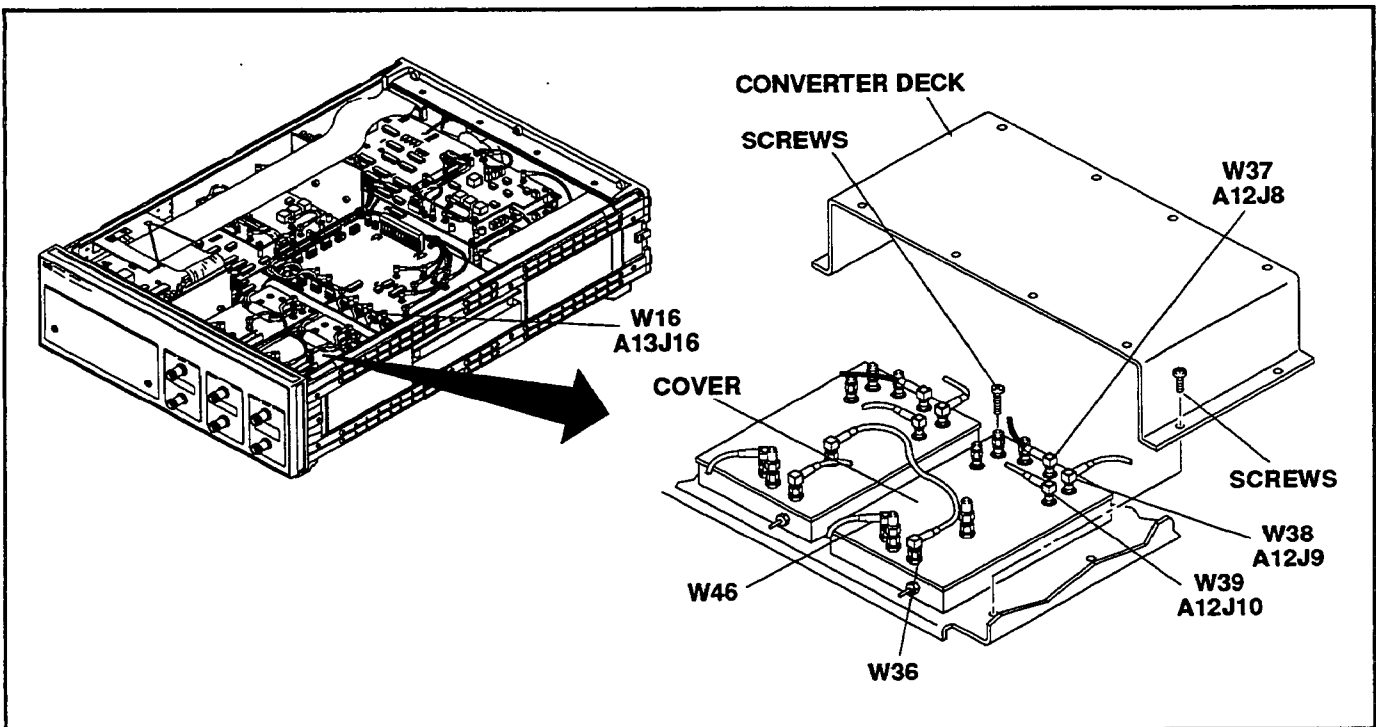

Figure 8-13. A12 Up Converter PCA Remove and Replace (STD/OPT 002)

**A12 Up Converter PCA
(OPT 001/003 ONLY)**

This procedure is used to remove the A12 Up Converter Printed Circuit Assembly. Figure 8-14 illustrates the parts.

1. Remove the top cover (instructions are provided earlier in this chapter).

2. Disconnect the following cables/terminations:

- W15 (RED)from A13J15
- W37 (VIOLET)from A12J5
- W38 (VIOLET)from A12J6
- W39 (VIOLET)from A12J7
- W30 (YELLOW)from A12J8
- W31 (YELLOW)from A12J9
- W32 (YELLOW)from A12J10
- W29 (BLU)from TO DOWN CONVERTER BLUE
- W40 (GRY)from AUX LO OUT REAR PANEL
- W43 (VIO)from RF OUTPUT FRONT PANEL

3. Remove the four Torx screws and cover. Note that the ferrite beads can remain in the spring clamps on the top cover. Lift out the A12 Up Converter PCA.

4. Reverse order to replace the A12 Up Converter PCA.

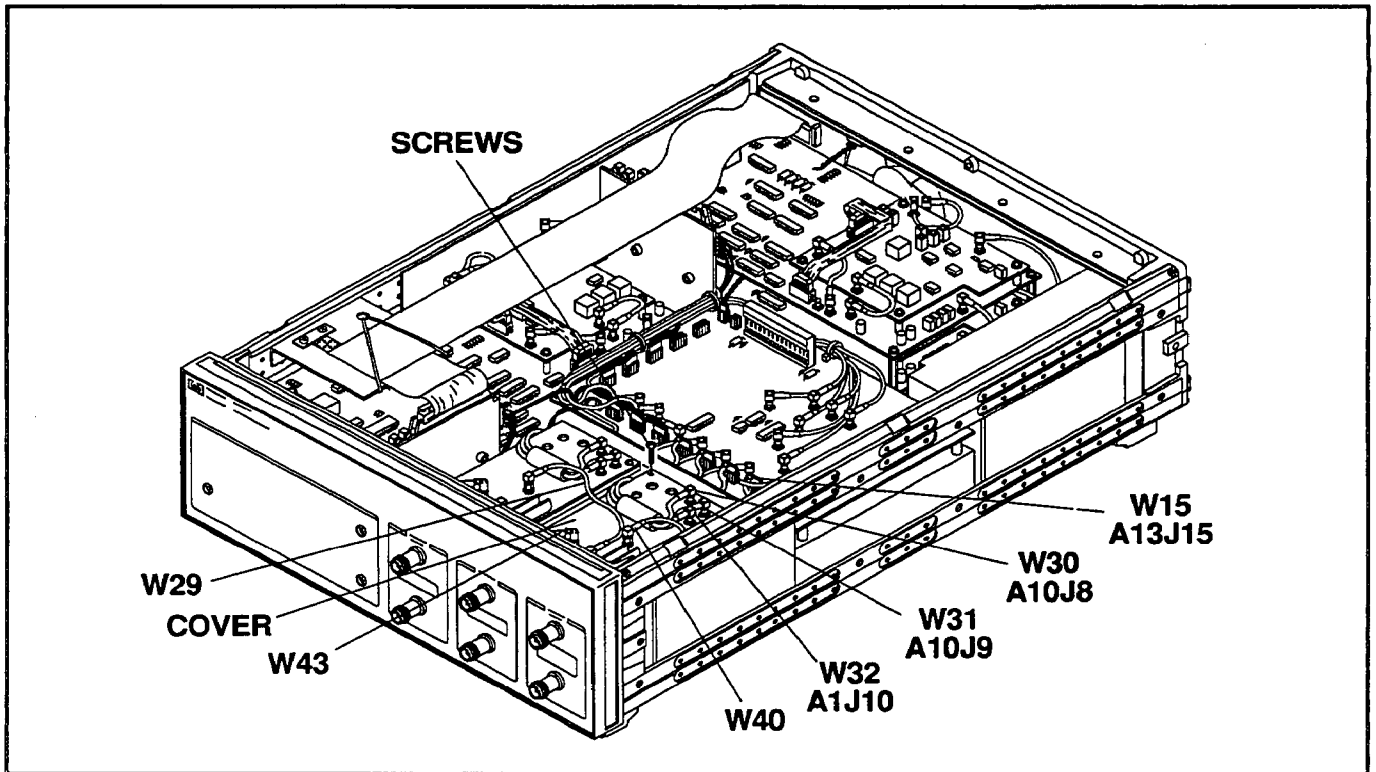

Figure 8-14. A12 Up Converter PCA Remove and Replace (OPT 001/003 ONLY)

A13 Clock/Divider PCA

This procedure is used to remove the A13 Clock/Divider Printed Circuit Assembly. Figure 8-15 illustrates the parts.

1. Remove the top cover (instructions are provided earlier in this chapter).

2. Disconnect the following cables:

| | | |
|---------------|-------|-------------|
| A16 | | from A13J28 |
| A17 | | from A13J22 |
| W1 (BRN) | | from A13J1 |
| W2 (WHT) | | from A13J2 |
| W3 (WHT) | | from A13J3 |
| W4 (WHT) | | from A13J4 |
| W5 (GRY/ORN) | | from A13J5 |
| W6 (GRY/ORN) | | from A13J6 |
| W7 (GRY/ORN) | | from A13J7 |
| W8 (WHT/RED) | | from A13J8 |
| W9 (WHT/RED) | | from A13J9 |
| W10 (WHT/RED) | | from A13J10 |
| W11 (YEL) | | from A13J11 |
| W12 (YEL) | | from A13J12 |
| W13 (YEL) | | from A13J13 |
| W14 (GRY) | | from A13J14 |
| W15 (RED) | | from A13J15 |
| W16 (RED) | | from A13J16 |
| W17 (RED) | | from A13J17 |
| W18 (RED) | | from A13J18 |
| W19 | | from A13J19 |
| W20 | | from A13J20 |
| W21 | | from A13J21 |
| W23 | | from A13J23 |
| W24 | | from A13J24 |
| W25 | | from A13J25 |

3. Remove five Torx screws, then remove the A13 Clock/Divider PCA.
4. Reverse order to replace the A13 Clock/Divider PCA.

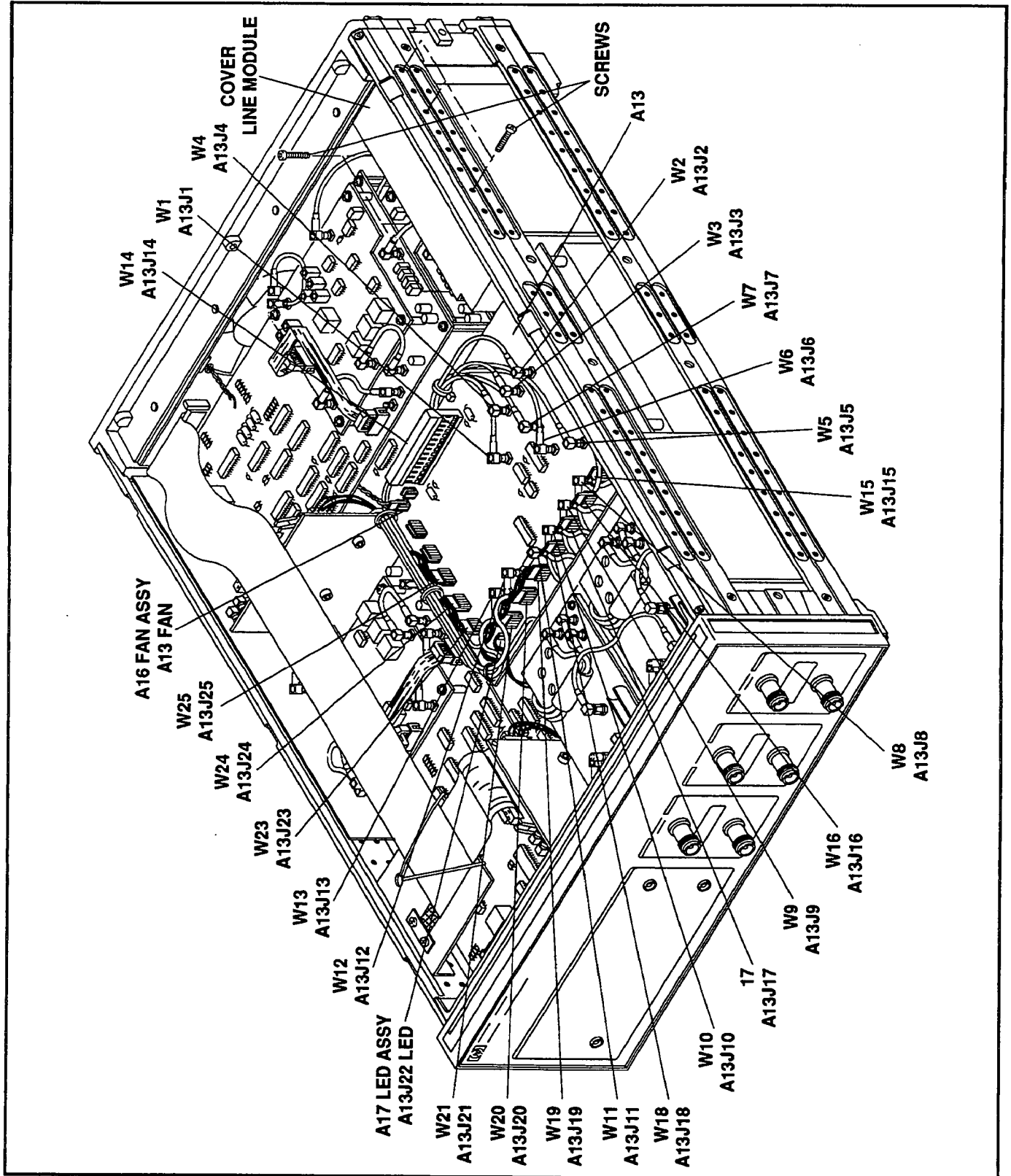

Figure 8-15. A13 Clock/Divider PCA Remove and Replace

A14 Power Supply

This procedure is used to remove the A14 Power Supply Assembly. Figure 8-16 illustrates the parts.

1. Remove the top cover (instructions are provided earlier in this chapter).
2. Remove the A13 Clock/Divider PCA (instructions are provided earlier in this chapter).
3. Remove the line module cover.
4. Disconnect the following cables/terminations:
 - W14 (GRY) between A13 and A14
 - W41 between A14 and A15
5. Remove six Torx screws holding the A14 Power Supply Assembly to the main deck. Remove the assembly from the Simulator.
6. Remove four screws, then the left-bracket.
7. Remove four screws, then the Z-bracket.
8. Reverse order to replace the A14 Power Supply Assembly.

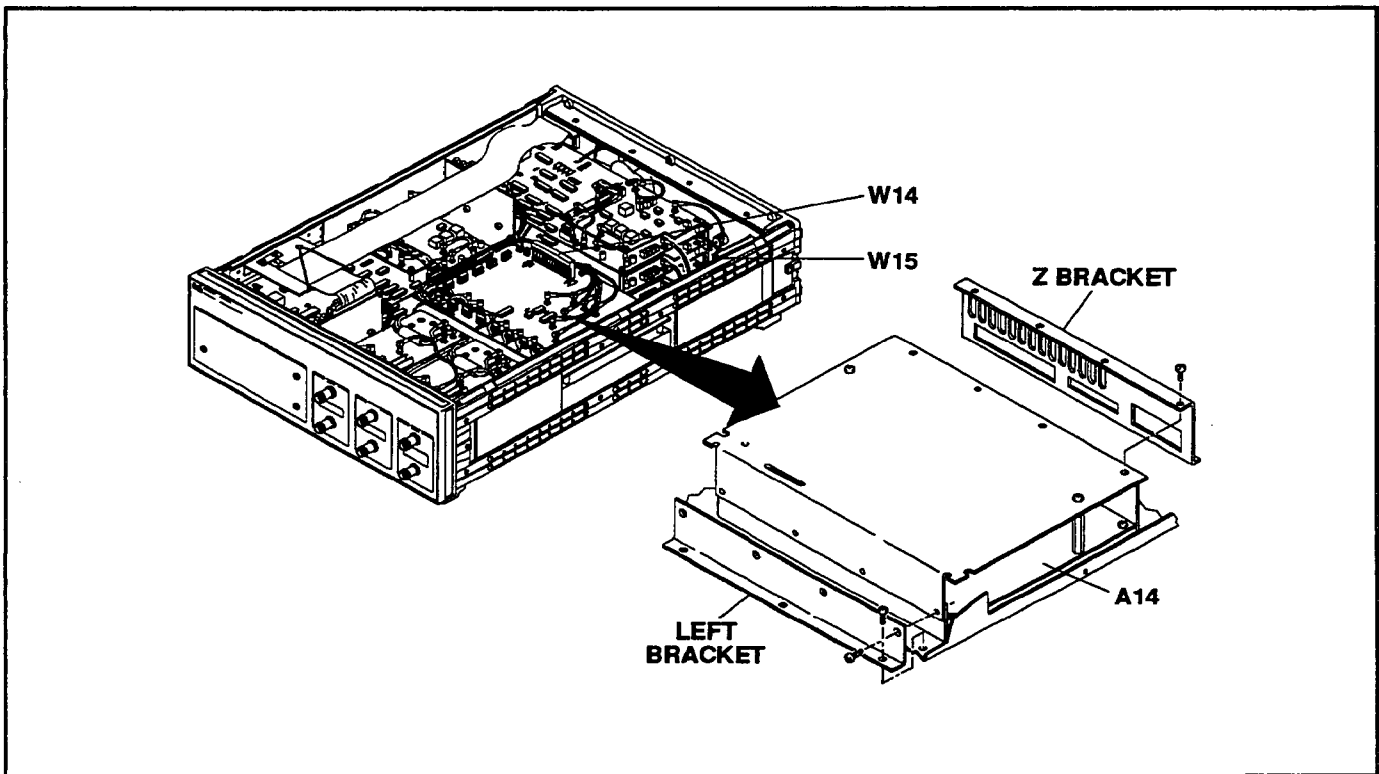

Figure 8-16. A14 Power Supply Assembly Remove and Replace

8-10. Periodic Maintenance

Cleaning Intervals

Hewlett-Packard recommends a 12-month interval between cleaning for some parts of the Simulator. Front panel connectors should be cleaned every 6 months. Cleaning intervals, however, are mostly dependent upon where the Simulator is used. The Simulator should be cleaned more frequently if used in a dusty or very humid area.

Cleaning Solution

Hewlett-Packard recommends either of two solutions for cleaning printed circuit (PC) board edge connectors. For best results, use an ammonium hydroxide solution (NH₄OH, 29.5% NH₂ by weight). However, concentrated ammonia is toxic, requiring gloves, goggles, and proper ventilation. An acceptable alternative is an 80:20 solution of isopropyl alcohol and water (IPA/H₂O). This should be a satisfactory cleaner where ammonium hydroxide is not feasible.

6-Month Cleaning

Careful cleaning of front panel connectors is essential to assure long, reliable connector life, to prevent accidental damage to connectors, and to obtain maximum measurement accuracy and repeatability.

Loose particles on the connector mating plane surfaces can usually be removed with a quick blast of compressed air.

Dirt and stubborn contaminants that cannot be removed with compressed air can often be removed with a cotton swab or lint-free cleaning cloth moistened with a solvent.

Note



Use the least amount of solvent possible, and avoid wetting any plastic parts in the connectors with the solvent.

Use liquid solvents rather than spray. If a spray must be used, always spray the solvent onto a cloth or swab, never directly into a connector.

Very dirty connectors can be cleaned with 91% isopropyl alcohol, HP Part No. 8500-0559. Do not use aromatic or chlorinated hydrocarbons, esters, ethers, terpenes, higher alcohols, ketones or ether-alcohols such as benzene toluene, turpentine, dioxane, gasoline, cellosolve acetate, or carbon tetrachloride.

Whichever solvent is used, carefully avoid wetting the plastic support bead inside the connector and blow the connector dry immediately with a gentle stream of compressed air. Support beads are easily damaged by solvents.

Interior surfaces, especially on precision connectors, are very difficult to reach, and it is easy to damage connectors in trying to clean them. One suitable method is to cut off the sharp tip of a round wooden toothpick and then to wrap it with a single layer of lint-free cleaning cloth. (A round wooden toothpick or a very small diameter wooden rod is required: metal must never be used because it will scratch the plated surfaces; diameter must not exceed 0.070 in. or 1.7 mm. Moisten the cloth with a small amount of cleaning solvent and carefully insert it into the connector to clean the interior surfaces. Use an illuminated magnifying glass or microscope to see clearly the areas you wish to clean.

When you have cleaned a connector, always be sure that it is completely dry before using it. Blow the connector dry with a gentle stream of clean compressed air and inspect it again under a magnifying glass to be sure that no particles or solvent residues remain.

12-Month Cleaning

Warning



Before cleaning, make sure the Simulator is disconnected from the power source. This is to eliminate the possibility of electrical shock.

Caution



This instrument contains static-sensitive devices such as CMOS integrated circuits. Because static-sensitive devices can be damaged by a vacuum cleaner, use only a soft-bristle brush or clean, dry ionized compressed air (maximum 20 psi 1.5 atm) for cleaning.

1. Remove the top and bottom covers to gain access to the interior of the instrument.
2. Using a brush, remove dirt from the fan guard and fan blades.
3. Using compressed air, remove dust and dirt from the area behind the fan. Blow air out through the fan and remove loose dirt.
4. Using air and/or a soft-bristle brush, clean all other accessible areas of the instrument, starting from the top, including the circuit boards.
5. Replace the instrument covers.

Specifications and Test Equipment

The specifications listed in Table A-1 are the performance standards or limits against which the instrument may be tested. The supplemental characteristics listed in Table A-2 are not warranted specifications, but are typical characteristics included as additional information for the user.

Unless otherwise specified, specifications are valid when measured using the following conditions:

- Temperature: +15°C to +35°C
- RF Input: 50/900/1800/2700 MHz at 0.1 dB lower than power overrange LED turn-on
- LO Input Frequency: RF input frequency -6 MHz at +10 dBm
- Controller: HP Vectra 486/33T, 4 MB Extended Memory, and MSDOS Version 5.0.

Table A-1. Specifications

| Characteristics | Performance Limits | Conditions |
|--|--|---|
| RF Input and Output | | |
| Independent Channels | 2 (STD), 1 (OPT 001, 003) | |
| Frequency Range | 40 MHz - 2700 MHz | |
| RF Input Level | -10 dBm nominal (+20dBm maximum damage level) | 40 MHz - 2700 MHz |
| Channel Simulation | | |
| Independent Paths | 6 | Three per Channel (STD), six per channel (OPT 001, 003) |
| Relative Amplitude Range | 0 to 50 dB, in 0.1 dB steps | Between Paths |
| Relative Delay Interval Range | 0 to 186 μ S in 1 nS steps 0 to 39.9 μ S, in 1 nS steps | Static Low Resolution Mode Travel Test Mode or Static High Resolution Mode |
| Simulated Vehicle Speed Range | 0 to \pm 509 kmh, in 0.1 km steps | Calculated at 900 MHz |
| Simulated Doppler Shift Range | 0 to \pm 425 Hz, in 0.1 Hz steps | |
| Relative Phase between Paths | 0 to \pm 360°, in 0.1° steps | Phase Spectrum Mode |
| Rayleigh Amplitude Distribution | Available on all paths | |
| Repetition Interval | >27 seconds | |
| Correlation Coefficient | 0 to 1, in 0.1 steps | |
| Temperature | | |
| Specification Range | +15°C to +35°C | |
| Operation Range | 0°C to +55°C | |

Table A-1. Specifications - Continued

| Characteristics | Performance Limits | Conditions |
|--------------------|--|--------------------------------|
| Humidity | 0 to 95% | +15°C to +35°C |
| Altitude | <4,600 meters (15,000 feet) | |
| Power Requirements | | |
| Line Voltage | 90 to 132/190 to 264 VAC | |
| Power | 275 VA Maximum 325 VA Maximum | 120 VAC/60 Hz 240 VAC/50 Hz |
| Frequency | 48 to 66 Hz | |
| Overall Dimensions | | |
| Height | 118 mm (5.25 inches) | |
| Width | 377 mm (16.75 inches) | |
| Length | 597 mm (23.5 inches) | |
| Weight | 35 lbs | |
| EMI | Conducted and radiated interference is within the requirements of EN55011, Group 1, Class A/CISPR Pub 11 (1990). Meets the requirements of EN50082-1 (1992)/IEC 801-2, -3, and -4. | |

Table A-2. Supplemental Characteristics

| Characteristics | Performance Limits | Conditions |
|--|--------------------------------------|--|
| RF Input and Output | | |
| Frequency Range | 40 MHz to 2000 MHz | |
| Channel Bandwidth | >6 MHz | 1 dB Bandwidth |
| Group Delay Variation | <±15 ns | 6 MHz Bandwidth |
| Path Insertion Loss* | 24 dB ±3.0 dB (40 MHz - 2700MHz) | Channel #1 or Channel #2 |
| Insertion Loss Variation | <0.1 dB | Path to path within a channel at band center |
| Path Insertion Delay | <600 ns | 0 ns delay |
| Path to Path Insertion Delay Variation | <±10 ns | At band center |
| Delta Isolation | -65 dB | |
| Path RFout S/N Ratio | -82 dBc | 10 kHz BW |
| RFout Spurious | -55 dBc | ±<3 MHz, Low delay resolution, Simulation Test |
| | -50 dBc | Travel Test, High delay resolution |
| Feedthrough on RF output | | |
| LO | <-20 dBm | |
| RF Image | 0 dBc, relative to desired RF output | RF Input Frequency less 2 x (RF - LO) |
| Impedance | 50 ohms | |
| Connector Type | Type N Female | |

* 25 ±4 dB (40 MHz to 2700 MHz) for rear panel connector option.

Table A-2. Supplemental Characteristics - Continued

| Characteristics | Performance Limits | Conditions |
|---|-------------------------------------|--------------------------------------|
| External LO Output | | |
| Frequency Range | 40 MHz to 2700 MHz | |
| Output Level** | >+7 dBm | |
| Frequency Offset | ±6.0 MHz | From RF Input |
| Impedance | 50 ohms | |
| Connector Type | Type N Female | |
| Channel Simulation | | |
| Relative Amplitude Accuracy (within a channel) | ±0.3 dB | 0-30 dB Attenuation |
| | ±1.0 dB | >30-40 dB Attenuation |
| | ±2.0 dB | >40-50 dB Attenuation |
| Relative Delay Interval Accuracy (within a channel) | ±0.5 ns + Insertion Delay variation | High Resolution (min 1 ns steps) |
| | ± 25 ns + Insertion Delay variation | Low Resolution (min 50 ns steps) |
| Deviation from Rayleigh CPDF* | <±1 dB | 10 dB above mean to 20 dB below mean |
| | <±3 dB | 20 dB below mean to 30 dB below mean |
| Deviation from Rayleigh LCR* | <±5% of vehicle speed | 10 dB above mean to 30 dB below mean |

* Note that due to Rayleigh repetition interval, performance degrades gradually for Doppler rates below 10 Hz.

** An external LO output level of +7 dBm is sufficient to drive the LO input of a second Simulator when connected with a low loss cable (approximately 1 dB of loss). However, path insertion loss may increase by up to 2 dB for LO levels close to +7 dBm.

The test equipment recommended for use in testing, adjusting, and servicing the Simulator is listed in Table A-3. Other equipment can be substituted if it meets or exceeds these critical specifications.

Table A-3. Recommended Test Equipment

| Instrument | Critical Specifications | Recommended | Use* |
|--|--|-------------|------|
| Cable (2 each) | Type N (m) both ends | HP 11500B | O,T |
| Controller | See paragraph 1-4 | | O,T |
| Spectrum Analyzer | 2.7 GHz spectrum capability | HP 8566B | O,T |
| Signal Generator (2 each) | 40 to 2700 MHz at +10 dBm, 10 MHz reference oscillator | HP 83732 | O,T |
| PORTTEST (requires): | | | |
| Logic Probe or DVM | | any | T |
| Parallel Printer | | HP 2228A | T |
| O=Operational Verification, P=Performance Verification, A=Adjustments, T=Troubleshooting | | | |

The following is a list of accessories recommended for use with the simulator system.

PC Controller

- HP Vectra 486/12 Model 120P/N HP 2247B
- VGA Color Display P/N HP D1194A
- 4MB Memory upgrade P/N HP D1642A
- Parallel interface cableP/N HP 24542D (2 m)
- HP-IB Interface (optional) P/N HP 82335B

Local Oscillator

- Signal Generator 0.1-2700 MHz P/N HP 83732A

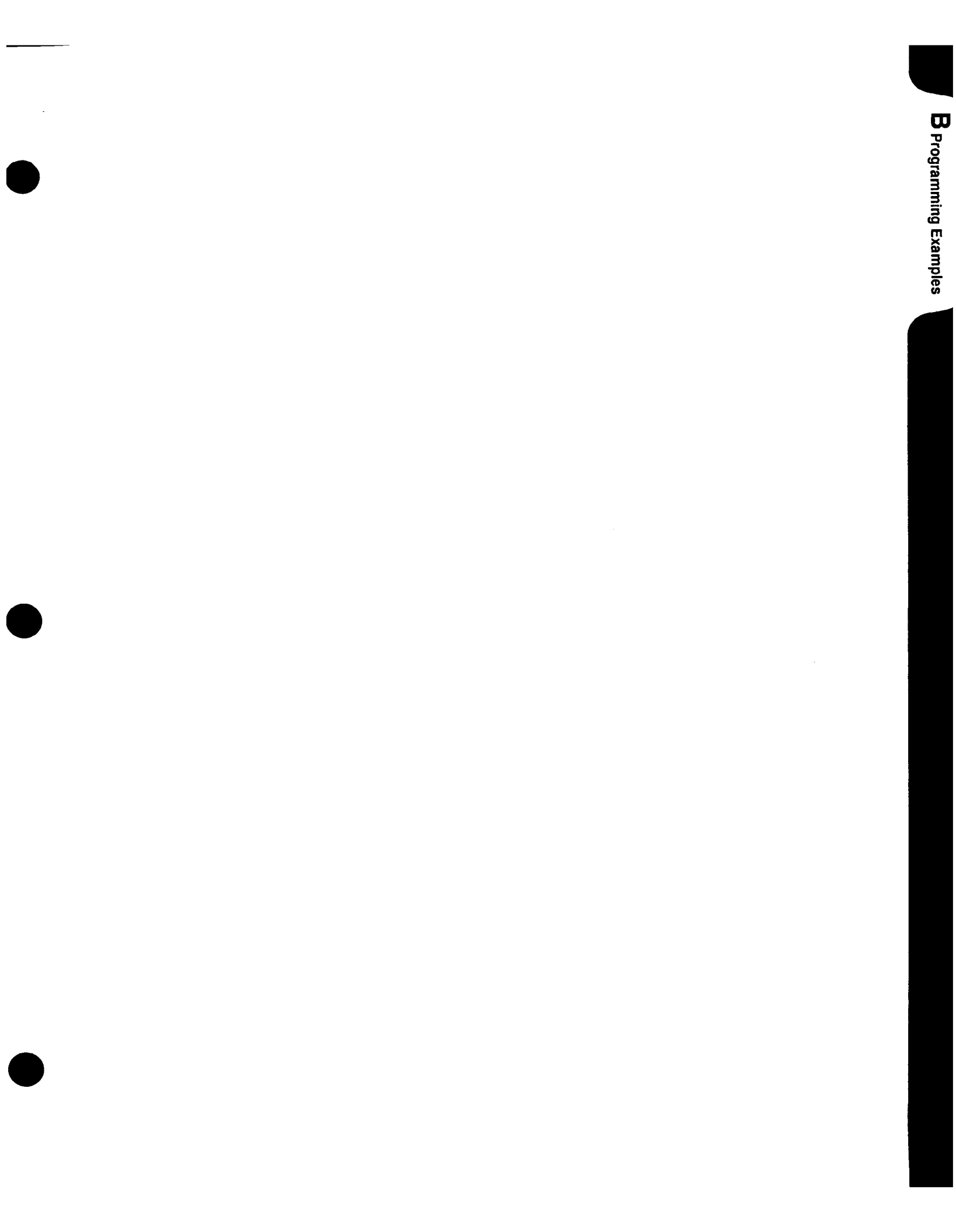

Programming Examples

Introduction

Programming examples that can be used to operate the Channel Simulation system using a remote controller are provided in this appendix. Unless otherwise specified, programming examples are written using:

- an HP Series 200/300 Computer with HP BASIC 4.0 or newer, on Basic Workstation

Programming Example #1

The following example is used to download a complete test setup to the Channel Simulator using the serial interface.

Note



Run the BASIC program before running RCHANSIM on the PC. The BASIC program needs to reset the serial interface before the PC runs, or the PC will report a "Time out on serial write." If that happens, just press ESCAPE on the PC keyboard, and then run the BASIC program first. Then run the RCHANSIM program when the BASIC program says to.

```

10 !                               RE-SAVE "RCHANSIM_PGM"
20 !
30 ! This program demonstrates how to download a setup and enter manual
40 ! commands remotely to the Channel Simulator software from BASIC on a
50 ! HP 9836A using a HP 98628A opt 002 datacom card with a HP 24542A cable
60 ! to the Vectra. Communication happens at 300 baud so the Channel
70 ! Simulator software (on the PC) can keep up.
80 !
90 ! TO RUN THIS PROGRAM:
100 !   o First, connect the serial cable per the REMOTE.DOC file that
110 !     comes with the first HP 11759C INSTALL disk.
120 !   o Second, Load and RUN this program.
130 !   o When the program says, start the RCHANSIM on the PC.
140 !   o Then press CONTINUE on the BASIC computer.
150 !
160 ! The program runs in two phases.
170 !
180 !   (1) The first phase downloads a Simulation Test setup from the
190 !       DATA statements at line 'Sim_setup' to the Channel Simulator.
200 !
210 !   (2) The second phase prompts the user to enter some remote commands
220 !       from the keyboard. This program then downloads it to the remote
230 !       controlled PC, and handles any resulting status or error messages.

```



```

240 !
250 ! THE IMPORTANT PART of this routine is the last subprogram in this
260 ! listing named 'Send_a_cmd()'. It sends one command to the PC
270 ! and handles any expected return status and error messages by
280 ! printing them to the ATE controller's screen.
290 !
300 ! This was written to run on a HP 9836A, a series 200 computer, running
310 ! HP BASIC 4.0. It should run on just about any version of HP "RMB" Basic
320 ! that can do the serial I/O.
330 !
340 DIM Cmd$(80)           ! Cmd to send to the Channel Simulator is put here.
350 !
360 GOSUB Main_init       ! Init SelectCode for Datacom port, init datacom card
370 !
380 DISP "Get RCHANSIM running on the PC in the main menu, & press CONTINUE on this keybd:"
390 PAUSE
400 DISP
410 !
420 RESTORE Sim_setup     ! Set the READ statment to read a Rayleigh test setup
430 GOSUB Send_setup      ! Read each DATA statement, send the cmd to the PC.
440 !
450 GOSUB Indiv_cmd       ! Send individual commands from the keyboard to the PC
460 DISP "Demo completed."
470 STOP                 ! Stop here, the demo has completed.
480 !
490 !
500 !
510 !!!!!!!!!!!!!!!!!!!!!!!!!!!!!!!!!!!!!!!!!!!!!!!!!!!!!!!!!!!!!!!!!!!!!!!!!!!!!!!
520 !!!!!!!             SUBROUTINES AND SUBPROGRAM FOLLOW             !!!!!!!
530 !!!!!!!!!!!!!!!!!!!!!!!!!!!!!!!!!!!!!!!!!!!!!!!!!!!!!!!!!!!!!!!!!!!!!!!!!!!!!!!
540 !
550 Main_init:           ! !!!!!!!!!!!!!!!!!!!!!!!!!!!!!!!!!!!!!!!!!!!!!!!!!!!!!!!!!!!!!!!
560 ! Initialize the Data Com select code variable 'Sc', and also set up the
570 ! HP 98628A datacom card so it works using the correct datacom parameters.
580 Sc=20                ! The select code of the HP 98628A interface card.
590 !
600 CONTROL Sc,0;1       ! Reset the card, flush any prev buffered traffic.
610 CONTROL Sc,8;2       ! Set the DTR line, this is very important to do!
620 !
630 ! The following 6 'CONTROL' statements set up the datacom parameters.
640 ! These are already set using the switches on the HP 98628A card, but
650 ! these commands are included here again for reference.
660 CONTROL Sc,20;7      ! 300 Baud, TRANSMIT
670 CONTROL Sc,21;7      ! 300 Baud, RECEIVE
680 CONTROL Sc,22;0      ! Protocall handshake disabled.
690 CONTROL Sc,34;2      ! 7 bits per character.
700 CONTROL Sc,35;0      ! one stop bit
710 CONTROL Sc,36;0      ! No parity.
720 RETURN               ! End of 'main_init' subroutine, back to 'main'.
730 !

```

```

740      !
750 Sim_setup:      !      !!!!!!!!!!!!!!!!!!!!!!!!!!!!!!!!!!!!!!!!!!!!!!!!!!!!!!!
760      ! These data statements define word remote commands which are sent
770      ! from the HP 9836A (or equivalent ATE controller) to a PC which is
780      ! running the HP 11759C Channel Simulator software.
790 DATA "IDENTIFY?"      ! Query the Channel Simulator Software's rev
800 DATA "MENU?"          ! Query currently disp menu; should be MAIN
810 DATA "MENU SIMULATION" ! Choose to run the Channel Simulation Test.
820 DATA "PATH 1"        ! Choose path one as the active path to work on,
830 DATA  "DELAY 5"      ! Set path 1 delay to 5 microseconds.
840 DATA  "DOPPLER 10"   ! Set path 1 Doppler to 10.0 Hz.
850 DATA  "ATTEN 2"     ! Set path 1 attenuation to 2 dB.
860 DATA  "SPECTRUM DOPPLER" ! Set path 1 to Doppler spectrum mode.
870 DATA "PATH 2"        ! Choose path two as the active path to work on,
880 DATA  "DELAY 10"    ! Set path 2 delay to 10 microseconds.
890 DATA  "DOPPLER 20"  ! Set path 2 Doppler to 20.0 Hz.
900 DATA  "ATTEN 4"     ! Set path 2 attenuation to 4 dB.
910 DATA  "SPECTRUM DOPPLER" ! Set path 2 to Doppler spectrum mode.
920 DATA "PATH 3"        ! Choose path three as the active path now.
930 DATA  "DELAY 15"    ! Set path 3's delay to 15 microseconds.
940 DATA  "DOPPLER 41.7" ! Set path 3 Doppler to 41.7 Hz.
950 DATA  "ATTEN 6"     ! and set path 3's attenuation to 6 dB.
960 DATA  "SPECTRUM RAYLEIGH"! Set path 3 to be spectrum type RAYLEIGH.
970 DATA "PATH 4"        ! Next, work on channel 2-- path 4= active path
980 DATA  "DELAY 20"    ! Specify 20 microseconds delay for path 4.
990 DATA  "DOPPLER 40"  ! Set path 4 Doppler to 40 Hz.
1000 DATA "ATTEN 8"      ! Specify 8 dB attenuation for path 4.
1010 DATA "CORRELATION .4" ! Path 1 to path 4 Rayleigh correlation of 0.4
1020 DATA  "SPECTRUM DOPPLER" ! Set path 4 to Doppler spectrum mode.
1030 DATA "PATH 5"        ! Change the active (current) path to path 5 now.
1040 DATA  "DELAY 25"   ! and set it's delay to 25 microseconds.
1050 DATA  "DOPPLER 50.0" ! Set path 5 Doppler to 50 Hz.
1060 DATA  "ATTEN 10"   ! and path 5's attenuation to 10 dB.
1070 DATA "CORRELATION .5" ! Path 2 to path 5 Rayleigh correlation of 0.5
1080 DATA  "SPECTRUM DOPPLER" ! Set path 5 to static Doppler mode.
1090 DATA "PATH 6"        ! Finally, set path 6 as the active path.
1100 DATA  "DELAY 30"   ! and set path 6's delay to 30 microseconds.
1110 DATA  "DOPPLER 41.7" ! Set path 6 Doppler to 41.7 Hz.
1120 DATA  "ATTEN 12"   ! and path 6's attenuation to 12 dB.
1130 DATA "CORRELATION .6" ! Path 3 to path 6 Rayleigh correlation of 0.6
1140 DATA  "SPECTRUM RAYLEIGH"! Set path 6 to be spectrum type RAYLEIGH.
1150 DATA ""            ! This blank string tells output loop to stop
1160      !

```

```

1170 !
1180 Send_setup:          ! !!!!!!!!!!!!!!!!!!!!!!!!!!!!!!!!!!!!!!!!!!!!!!!!!!!!!!!
1190 ! Read DATA statements (set by previous RESTORE cmd) and send each string
1200 ! out to the PC that's running the Channel Simulator software.
1210 REPEAT              ! Read each command that's part of the
1220   READ Next_cmd$     ! setup to be downloaded from DATA.
1230   IF Next_cmd$="" THEN      ! If this cmd is not the end-of-list ""
1240     CALL Send_a_cmd(Sc,Next_cmd$) ! Then go ahead & send it to the PC.
1250   END IF            !   & handle status, error returns.
1260   UNTIL Next_cmd$=""      ! Keep sending DATA cmds till @end
1270 RETURN
1280 !
1290 !
1300 Indiv_cmd:          ! !!!!!!!!!!!!!!!!!!!!!!!!!!!!!!!!!!!!!!!!!!!!!!!!!!!!!!!
1310 ! Keep accepting one command from the keyboard, and sending it to the
1320 ! Channel simulator, until the user presses RETURN to stop.
1330 REPEAT
1340   LINPUT "Enter the remote command for the Channel Simulator: ",Cmd$
1350   IF Cmd$="" THEN      ! If user did not just press RETURN
1360     CALL Send_a_cmd(Sc,Cmd$) ! then user entered a cmd; send it to PC
1370   END IF              !   and handle status, error returns
1380   UNTIL Cmd$=""       ! Keep asking user for more cmds
1390 RETURN                ! until no more entered, then return
1400 !
1410 !
1420 END                    ! End of main & subroutines, begin
1430                        ! defining the subprograms (only 1).
1440 !
1450 !
1460 !!!!!!!!!!!!!!!!!!!!!!!!!!!!!!!!!!!!!!!!!!!!!!!!!!!!!!!!!!!!!!!!!!!!!!!
1470 !!!!!!!                SUBPROGRAM   DEFINED                !!!!!!!
1480 !!!!!!!!!!!!!!!!!!!!!!!!!!!!!!!!!!!!!!!!!!!!!!!!!!!!!!!!!!!!!!!!!!!!!!!
1490 !
1500 Send_a_cmd:SUB Send_a_cmd(Sc,Cmd$) ! !!!!!!!!!!!!!!!!!!!!!!!!!!!!!!!!!!!!!!!
1510 ! Send a command to the remote controlled PC. The 'Sc' param is the select
1520 ! code of the HP 98628A interface card that is installed in the HP 9836A
1530 ! (or equivalent) computer. The 'Cmd$' is the command to sent to the PC.
1540 !
1550 ! ALGORITHM:
1560 !   Clear the input buffer--
1570 !     o First, the input buffer on the HP 98628A is cleared of any previous
1580 !       text that may have been sent by the Channel Simulator sw.
1590 !   Preprocess the command--
1600 !     o The command is trimmed of leading & trailing spaces.
1610 !     o If there was no entered command, then exit without doing anything
1620 !       else.

```

```

1630 !   o Print to this ATE controller computer's screen the cmd to be sent
1640 !     out.  If that command is a Ctl-[ (escape code), then just print
1650 !     <esc>.
1660 !   Send the Command to the PC--
1670 !     o If the command is a single character, then it is assumed to be a
1680 !     single-code command, so it is sent without a trailing <cr>.
1690 !     o Else the cmd is more than one character, so it is sent as a word
1700 !     command with a trailing <cr>.
1710 !   Get back the status & return messages (if any)--
1720 !     o If the sent command was not an ESCAPE, and it was only 1 character
1730 !     long, then the PC is not expected to return any sort of status, so
1740 !     subexit.
1750 !     o Else a possible error message, and ?? are expected, or just a ok is
1760 !     expected back from the PC.  So go into a loop & keep reading & printing
1770 !     any messages, until either the ?? error status or the OK
1780 !     status is read.  The expected return traffic is one of:
1790 !           OK<cr><lf>           or           <ErrMsg><cr><lf>??<cr><lf>
1800 !   Then exit back to the caller.
1810 !
1820 DIM A$[80]           ! Input lines are read back into this string.
1830 !
1840 ! *** Clear the input buffer
1850 REPEAT               ! Keep reading input buffer till it is empty.
1860   STATUS Sc,5;Inbuf_status ! Check the status of the input queue.
1870   IF Inbuf_status>0 THEN   ! If the input buffer has some old data,
1880     ENTER Sc USING "K";A$   ! then do a read to clear out the old message.
1890   END IF
1900 UNTIL Inbuf_status=0     ! Repeat, in case there are more messages in
1910 !                         ! the buffer.
1920 ! *** Preprocess the command.
1930 Cmd$=TRIM$(Cmd$)        ! Remove any leading & trailing spaces from cmd
1940 IF LEN(Cmd$)=0 THEN SUBEXIT ! If the cmd being sent is nonexistent, exit.
1950 !
1960 IF Cmd$=CHR$(27) THEN    ! If the command being sent is the escape code,
1970   PRINT "<esc>"          ! print that the ESCAPE key (ctl-[) is cmd.
1980 ELSE                     ! ELSE assume the cmd is printable directly, & print
1990   PRINT Cmd$              ! the cmd which will be sent to the PC.
2000 END IF
2010 !
2020 !
2030 ! *** Send the Command to the PC
2040 IF LEN(Cmd$)=1 THEN      ! If cmd is a one-key command like ESCAPE,
2050   OUTPUT Sc USING "#,K";Cmd$ ! then output the cmd w/out trailing <cr>.
2060 ELSE                     ! Else assume it is a word command,
2070   OUTPUT Sc USING "+,K";Cmd$ ! and output it with a trailing <cr> char.
2080 END IF
2090 !

```

```
2100 !
2110 ! *** Get back the status & return messages (if any).
2120 IF Cmd$<>CHR$(27) AND LEN(Cmd$)=1 THEN ! ..then it is a one-code command
2130   SUBEXIT                               ! which has no return status, so
2140 END IF                                   ! subexit w/out waiting for ok.
2150 !
2160 ! If got to here, then the command was either an ESCAPE key, or it was a
2170 ! command of more than one character in length (a word cmd). So
2180 ! it should have some echo coming back from the PC-- and err & ??, or
2190 ! a query ret value (if a query) & the word "OK".
2200 REPEAT                                   ! Repeatedly grab lines of serial port
2210   ENTER Sc USING "K";A$                 ! Get next msg ' from PC, cr/lf terminated
2220   PRINT A$                               ! Print the message (error or status).
2230 UNTIL A$="OK" OR A$="?"                ! Keep reading until error or ok status.
2240 SUBEND                                   ! Finally, exit back to calling routine
```

Programming Example #2

The following example is used to download a complete test setup to the Channel Simulator using the HP-IB interface.

Note



Run this BASIC program before running HCHANSIM (11759C) or HGHOST (11759D) on the PC. If HCHANSIM or HGHOST is already running, this BASIC program requires that the MAIN MENU is currently running on the PC.

```

10 !                                     RE-SAVE "SAMPLE_PGM"
20 !
30 ! This program demonstrates how to download a setup and enter manual
40 ! commands remotely to the Channel Simulator software from BASIC on a
50 ! HP 9836A using HP-IB connected to the Vectra.
80 !
90 ! TO RUN THIS PROGRAM:
100 !   o First, connect the HP-IB cable
120 !   o Second, Load and RUN this program.
130 !   o When the program says, start the HCHANSIM or HGHOST on the PC.
140 !   o Then press CONTINUE on the BASIC computer.
150 !
160 ! The program runs in two phases.
170 !
180 !   (1) The first phase downloads a Simulation Test setup from the
190 !       DATA statements at line 'Sim_setup' to the Channel Simulator.
200 !
210 !   (2) The second phase prompts the user to enter some remote commands
220 !       from the keyboard. This program then downloads it to the remote
230 !       controlled PC, and handles any resulting status or error messages.
240 !
250 ! THE IMPORTANT PART of this routine is the last subprogram in this
260 ! listing named 'Send_a_cmd()'. It sends one command to the PC
270 ! and handles any error messages by
280 ! printing them to the ATE controller's screen.
290 !
300 ! This was written to run on a HP 9836A, a series 200 computer, running
310 ! HP BASIC 4.0. It should run on just about any version of HP "RMB" Basic
320 ! that can do the HP-IB I/O.
330 !
340 DIM Cmd$(80)           ! Cmd to send to the Channel Simulator is put here.
350 !
360 GOSUB Main_init       ! Init SelectCode for HP-IB port
370 !
380 DISP "Get HCHANSIM/HGHOST running on PC in main menu, then CONTINUE on this keybd:"
390 PAUSE
400 DISP
410 !
420 RESTORE Sim_setup     ! Set the READ statment to read a Rayleigh test setup
430 GOSUB Send_setup      ! Read each DATA statement, send the cmd to the PC.

```

```

440 !
450 GOSUB Indiv_cmd      ! Send individual commands from the keyboard to the PC
460 DISP "Demo completed."
470 STOP                ! Stop here, the demo has completed.
480 !
490 !
500 !
510 !!!!!!!!!!!!!!!!!!!!!!!!!!!!!!!!!!!!!!!!!!!!!!!!!!!!!!!!!!!!!!!!!!!!!!!!!!!!!!!
520 !!!!!!!!!          SUBROUTINES AND SUBPROGRAM FOLLOW          !!!!!!!!!!!!!!!!!!!!!!!
530 !!!!!!!!!!!!!!!!!!!!!!!!!!!!!!!!!!!!!!!!!!!!!!!!!!!!!!!!!!!!!!!!!!!!!!!!!!!!!!!
540 !
550 Main_init:          ! !!!!!!!!!!!!!!!!!!!!!!!!!!!!!!!!!!!!!!!!!!!!!!!!!!!!!!!!!!!!!!!
560 ! Initialize the HP-IB select code variable 'Sc'
570 Sc=7                ! The select code of the HP 98628A interface card.
580 Address=14          ! The HP-IB address of the PC running the
590 !                  ! Channel Simulator software.
590 Dev=Sc*100+Address  ! Device code used by OUTPUT and ENTER commands
600 !
720 RETURN              ! End of 'main_init' subroutine, back to 'main'.
730 !
740 !
750 Sim_setup:         !          ! !!!!!!!!!!!!!!!!!!!!!!!!!!!!!!!!!!!!!!!!!!!!!!!!!!!!!!!
760 ! These data statements define word remote commands which are sent
770 ! from the HP 9836A (or equivalent ATE controller) to a PC which is
780 ! running the HP 11759C/D Channel Simulator software.
780 ! The second parameter is how many seconds to wait before sending
785 ! any more HP-IB commands.
790 DATA "*IDN?",0      ! Query the Channel Simulator Software's rev
800 DATA "PROG:NAME?",0 ! Query currently disp menu; should be MAIN
810 DATA "PROG:NAME SIMULATION",10 ! Choose to run Channel Simulation Test and
820 !                  ! must wait 10 seconds before outputting more
830 DATA "SMOD1:DEL 5E-6",0 ! Set path 1 delay to 5 microseconds.
840 DATA "SMOD1:DOPP:FREQ 10",0 ! Set path 1 Doppler to 10.0 Hz.
850 DATA "SMOD1:ATT 2",0 ! Set path 1 attenuation to 2 dB.
860 DATA "SMOD1:SPEC DOPP",0 ! Set path 1 to Doppler spectrum mode.
880 DATA "SMOD2:DELAY 10E-6",0 ! Set path 2 delay to 10 microseconds.
890 DATA "SMOD2:DOPP:FREQ 20",0 ! Set path 2 Doppler to 20.0 Hz.
900 DATA "SMOD2:ATT 4",0 ! Set path 2 attenuation to 4 dB.
910 DATA "SMOD2:SPEC DOPP",0 ! Set path 2 to Doppler spectrum mode.
930 DATA "SMOD3:DELAY 15E-6",0 ! Set path 3's delay to 15 microseconds.
940 DATA "SMOD3:DOPP:FREQ 41.7",0 ! Set path 3 Doppler to 41.7 Hz.
950 DATA "SMOD3:ATT 6",0 ! and set path 3's attenuation to 6 dB.
960 DATA "SMOD3:SPEC DOPP",0 ! Set path 3 to Doppler spectrum mode.
980 DATA "SMOD4:DEL 20E-6",0 ! Specify 20 microseconds delay for path 4.
990 DATA "SMOD4:DOPP:FREQ 40",0 ! Set path 4 Doppler to 40 Hz.
1000 DATA "SMOD4:ATT 8",0 ! Specify 8 dB attenuation for path 4.
1020 DATA "SMOD4:SPEC DOPP",0 ! Set path 4 to Doppler spectrum mode.
1040 DATA "SMOD5:DEL 25E-6",0 ! and set it's delay to 25 microseconds.
1050 DATA "SMOD5:DOPP:FREQ 50.0",0 ! Set path 5 Doppler to 50 Hz.

```

```

1060 DATA "SMOD5:ATT 10",0      ! and path 5's attenuation to 10 dB.
1080 DATA "SMOD5:SPEC DOPP",0  ! Set path 5 to static Doppler mode.
1100 DATA "SMOD6:DEL 30E-6",0  ! and set path 6's delay to 30 microseconds.
1110 DATA "SMOD6:DOPP:FREQ 41.7",0 ! Set path 5 Doppler to 41.7 Hz.
1120 DATA "SMOD6:ATT 12",0     ! and path 6's attenuation to 12 dB.
1140 DATA "SMOD6:SPEC DOPP",0  ! Set path 6 to static Doppler mode.
1150 DATA "",0                 ! This blank string tells output loop to stop
1160 !
1170 !
1180 Send_setup:                ! !!!!!!!!!!!!!!!!!!!!!!!!!!!!!!!!!!!!!!!!!!!!!!!!!!!!!!!!!!!!!!!
1190 ! Read DATA statements (set by previous RESTORE cmd) and send each string
1200 ! out to the PC that's running the Channel Simulator software.
1210 REPEAT                    ! Read each command that's part of the
1220   READ Cmd$,Wait_time      ! setup to be downloaded from DATA.
1240   IF Cmd$<>"" THEN        ! If this cmd is not the end-of-list "",
1250     CALL Send_a_cmd(Sc,Dev,Cmd$,Wait_time) ! go ahead & send to the PC.
1260   END IF                  ! & handle error messages.
1280 UNTIL Cmd$=""            ! Keep sending DATA cmds till @end
1285 RETURN
1290 !
1295 !
1300 Indiv_cmd:                 ! !!!!!!!!!!!!!!!!!!!!!!!!!!!!!!!!!!!!!!!!!!!!!!!!!!!!!!!!!!!!!!!
1310 ! Keep accepting one command from the keyboard, and sending it to the
1320 ! Channel simulator, until the user presses RETURN to stop.
1330 REPEAT
1335   LINPUT "Enter the remote command for the Channel Simulator: ",Cmd$
1340   Wait_time=0              ! Assume no waiting
1345   INPUT "Enter the wait time before sending more HP-IB commands:",Wait_time
1350   IF Cmd$<>"" THEN        ! If user did not just press RETURN
1360     CALL Send_a_cmd(Sc,Dev,Cmd$,Wait_time) ! cmd entered; send it to PC
1370   END IF                  ! and handle error messages.
1380 UNTIL Cmd$=""            ! Keep asking user for more cmds
1390 RETURN                    ! until no more entered, then return
1400 !
1410 !
1420 END                        ! End of main & subroutines, begin
1430                          ! defining the subprograms (only 1).
1440 !
1450 !
1460 !!!!!!!!!!!!!!!!!!!!!!!!!!!!!!!!!!!!!!!!!!!!!!!!!!!!!!!!!!!!!!!!!!!!!!!
1470 !!!!!!!                      SUBPROGRAM   DEFINED                      !!!!!!!!!!!!!!!!!!!!!!!!!!!!!!!!!!!!!!!
1480 !!!!!!!!!!!!!!!!!!!!!!!!!!!!!!!!!!!!!!!!!!!!!!!!!!!!!!!!!!!!!!!!!!!!!!!
1490 !
1500 Send_a_cmd:SUB Send_a_cmd(Sc,Dev,Cmd$,Wait_time) ! !!!!!!!!!!!!!!!!!!!!!!!!!!!!!!!!!!!!!!!
1510 ! Send a command to the remote controlled PC. The 'Sc' param is the select
1515 ! code of the HP-IB card that is installed in the HP 9836A (or equivalent)
1520 ! computer. The 'Dev' param contains the the select code and 'Dev'
1530 ! contains the HP-IB bus address of the PC running the Channel Simulator
1535 ! software. The 'Cmd$' is the command to sent to the PC.
1540 ! The 'Wait_time' is the number of seconds to wait after sending the
1545 ! command before any other HP-IB commands can be sent.

```



```

1550 !
1555 ! ALGORITHM:
1560 !   Clear the input buffer--
1570 !     o First, clear the Channel Simulator software's error queue.
1590 !   Preprocess the command--
1600 !     o The command is trimmed of leading & trailing spaces.
1610 !     o If there was no entered command, then exit without doing anything
1620 !       else.
1630 !     o Print to this ATE controller computer's screen the cmd to be sent
1640 !       out.
1660 !   Send the Command to the PC--
1690 !     o The cmd is sent as a word command with a trailing <lf>.
1690 !     o If command was a query, enter the response and display it.
1690 !     o Wait for 'Wait_time' seconds
1710 !   Check the error queue for errors (if any)--
1750 !     o Go into a loop & keep reading & printing
1770 !       any messages, until the +0,"No error" message
1780 !       is read. The expected return traffic is one of:
1790 !         +0,"No error"<lf>           or           <ErrMsg><lf>
1800 !   Then exit back to the caller.
1810 !
1820 DIM A$(2000)           ! Input lines are read back into this string.
1830 !
1840 ! *** Clear the Channel Simulator software's error queue
1900 OUTPUT Dev;"*CLS"     ! Clears the error queue
1910 !
1920 ! *** Preprocess the command.
1930 Cmd$=TRIM$(Cmd$)      ! Remove any leading & trailing spaces from cmd
1940 IF LEN(Cmd$)=0 THEN SUBEXIT ! If the cmd being sent is nonexistent, exit.
1950 !
1990 PRINT Cmd$           ! print the cmd which will be sent to the PC.
2010 !
2020 !
2030 ! *** Send Command to the PC (which is running the Channel Simulator sw)
2040 OUTPUT Dev;Cmd$      ! output it with a trailing <lf> char.
2050 IF POS(Cmd$,"*quote;?") THEN ! If the command was a query
2055   ON TIMEOUT Sc,5 GOTO Wait_here ! Set timeout in case query was bad
2060   ENTER Dev;A$        ! Read in the query response
2070   PRINT A$           ! Print the query response
2075 END IF              !
2080 !
2085 Wait_here: !
2090   OFF TIMEOUT        ! Turn off any timeouts
2095 WAIT Wait_time     ! Wait if required
2100 !

```

```
2105 !
2110 ! *** Check the error queue for errors (if any).
2200 REPEAT ! Repeatedly query the error queue
2210 OUTPUT Dev;"SYST:ERR?" ! Get next msg from PC, <lf> terminated
2220 ENTER Dev;A$ ! Get next msg from PC, <lf> terminated
2230 PRINT A$ ! Print the error message.
2240 UNTIL A$="+0,""No error"" ! Keep reading until queue is empty.
2250 SUBEND ! Finally, exit back to calling routine
```

Standard Profiles

Introduction

Parameters for the four predefined standard profiles that can be called up during the Simulation Tests are as follows:

Profile #1 TITLE - "GSM/PCN RAX Rural Area, 6-tap setting, option 1"

| | | | | | | | | |
|-------------|-----|-----|-----|-----|-----|------|------|-------------------|
| SPECTRUM | DOP | RAY | RAY | RAY | RAY | RAY | RAY | |
| DELAY_US | 0.0 | 0.0 | 0.1 | 0.2 | 0.3 | 0.4 | 0.5 | |
| DOPPLER_HZ | 0.0 | 0.0 | 0.0 | 0.0 | 0.0 | 0.0 | 0.0 | # Supplied by pgm |
| ATTEN_DB | 6.6 | 3.6 | 0.0 | 4.0 | 8.0 | 12.0 | 16.0 | |
| CORRELATION | 0.0 | 0.0 | 0.0 | 0.0 | 0.0 | 0.0 | 0.0 | # No correlation |

Profile #2 TITLE - "GSM/PCN RAX Rural Area, 6-tap setting, option 2"

| | | | | | | | |
|-------------|-----|-----|-----|-----|------|-----|-------------------|
| SPECTRUM | DOP | RAY | RAY | RAY | RAY | OFF | |
| DELAY_US | 0.0 | 0.0 | 0.2 | 0.4 | 0.6 | 0.0 | |
| DOPPLER_HZ | 0.0 | 0.0 | 0.0 | 0.0 | 0.0 | 0.0 | # Supplied by pgm |
| ATTEN_DB | 8.4 | 6.9 | 0.0 | 8.0 | 18.0 | 0.0 | |
| CORRELATION | 0.0 | 0.0 | 0.0 | 0.0 | 0.0 | 0.0 | # No correlation |

Profile #3 TITLE - "GSM/PCN HTx Hilly Terrain, 6-tap setting, option 1"

| | | | | | | | |
|-------------|-----|-----|-----|-----|------|------|-------------------|
| SPECTRUM | RAY | RAY | RAY | RAY | RAY | RAY | |
| DELAY_US | 0.0 | 0.1 | 0.3 | 0.5 | 15.0 | 17.2 | |
| DOPPLER_HZ | 0.0 | 0.0 | 0.0 | 0.0 | 0.0 | 0.0 | # Supplied by pgm |
| ATTEN_DB | 0.0 | 1.5 | 4.5 | 7.5 | 8.0 | 17.7 | |
| CORRELATION | 0.0 | 0.0 | 0.0 | 0.0 | 0.0 | 0.0 | # No correlation |

Profile #4 TITLE - "GSM/PCN TUX Typical Urban Area, 6-tap setting, option 1"

| | | | | | | | |
|-------------|-----|-----|-----|-----|-----|------|-------------------|
| SPECTRUM | RAY | RAY | RAY | RAY | RAY | RAY | |
| DELAY_US | 0.0 | 0.2 | 0.5 | 1.6 | 2.3 | 5.0 | |
| DOPPLER_HZ | 0.0 | 0.0 | 0.0 | 0.0 | 0.0 | 0.0 | # Supplied by pgm |
| ATTEN_DB | 3.0 | 0.0 | 2.0 | 6.0 | 8.0 | 10.0 | |
| CORRELATION | 0.0 | 0.0 | 0.0 | 0.0 | 0.0 | 0.0 | # No correlation |

Profile #5 TITLE - "GSM/PCN EQx Equalization Test Profile"

| SPECTRUM | RAY | RAY | RAY | RAY | RAY | RAY | RAY |
|-------------|-----|-----|-----|-----|------|------|----------------------|
| DELAY_US | 0.0 | 3.2 | 6.4 | 9.6 | 12.8 | 16.0 | |
| DOPPLER_HZ | 0.0 | 0.0 | 0.0 | 0.0 | 0.0 | 0.0 | # Supplied by pgm |
| ATTEN_DB | 0.0 | 0.0 | 0.0 | 0.0 | 0.0 | 0.0 | # Should all be zero |
| CORRELATION | 0.0 | 0.0 | 0.0 | 0.0 | 0.0 | 0.0 | # No correlation |

Profile #6 TITLE - "GSM/PCN HTx Hilly Terrain, 12-tap setting, option 1"

| SPECTRUM | RAY | RAY | RAY | RAY | RAY | RAY | RAY | RAY | RAY | RAY | RAY | RAY |
|-------------|------|-----|-----|-----|-----|-----|-----|------|------|------|------|------|
| DELAY_US | 0.0 | 0.1 | 0.3 | 0.5 | 0.7 | 1.0 | 1.3 | 15.0 | 15.2 | 15.7 | 17.2 | 20.0 |
| DOPPLER_HZ | 0.0 | 0.0 | 0.0 | 0.0 | 0.0 | 0.0 | 0.0 | 0.0 | 0.0 | 0.0 | 0.0 | 0.0 |
| ATTEN_DB | 10.0 | 8.0 | 6.0 | 4.0 | 0.0 | 0.0 | 4.0 | 8.0 | 9.0 | 10.0 | 12.0 | 14.0 |
| CORRELATION | 0.0 | 0.0 | 0.0 | 0.0 | 0.0 | 0.0 | 0.0 | 0.0 | 0.0 | 0.0 | 0.0 | 0.0 |

Profile #7 TITLE - "GSM/PCN HTx Hilly Terrain, 12-tap setting, option 2"

| SPECTRUM | RAY | RAY | RAY | RAY | RAY | RAY | RAY | RAY | RAY | RAY | RAY | RAY |
|-------------|------|-----|-----|-----|-----|-----|-----|------|------|------|------|------|
| DELAY_US | 0.0 | 0.2 | 0.4 | 0.6 | 0.8 | 2.0 | 2.4 | 15.0 | 15.2 | 15.8 | 17.2 | 20.0 |
| DOPPLER_HZ | 0.0 | 0.0 | 0.0 | 0.0 | 0.0 | 0.0 | 0.0 | 0.0 | 0.0 | 0.0 | 0.0 | 0.0 |
| ATTEN_DB | 10.0 | 8.0 | 6.0 | 4.0 | 0.0 | 0.0 | 4.0 | 8.0 | 9.0 | 10.0 | 12.0 | 14.0 |
| CORRELATION | 0.0 | 0.0 | 0.0 | 0.0 | 0.0 | 0.0 | 0.0 | 0.0 | 0.0 | 0.0 | 0.0 | 0.0 |

Profile #8 TITLE - "GSM/PCN TUx Typical Urban, 12-tap setting, option 1"

| SPECTRUM | RAY | RAY | RAY | RAY | RAY | RAY | RAY | RAY | RAY | RAY | RAY | RAY |
|-------------|-----|-----|-----|-----|-----|-----|-----|-----|-----|-----|------|------|
| DELAY_US | 0.0 | 0.1 | 0.3 | 0.5 | 0.8 | 1.1 | 1.3 | 1.7 | 2.3 | 3.1 | 3.2 | 5.0 |
| DOPPLER_HZ | 0.0 | 0.0 | 0.0 | 0.0 | 0.0 | 0.0 | 0.0 | 0.0 | 0.0 | 0.0 | 0.0 | 0.0 |
| ATTEN_DB | 4.0 | 3.0 | 0.0 | 2.6 | 3.0 | 5.0 | 7.0 | 5.0 | 6.5 | 8.6 | 11.0 | 10.0 |
| CORRELATION | 0.0 | 0.0 | 0.0 | 0.0 | 0.0 | 0.0 | 0.0 | 0.0 | 0.0 | 0.0 | 0.0 | 0.0 |

Profile #9 TITLE - "GSM/PCN TUx Typical Urban, 12-tap setting, option 2"

| SPECTRUM | RAY | RAY | RAY | RAY | RAY | RAY | RAY | RAY | RAY | RAY | RAY | RAY |
|-------------|-----|-----|-----|-----|-----|-----|-----|-----|-----|-----|------|------|
| DELAY_US | 0.0 | 0.2 | 0.4 | 0.6 | 0.8 | 1.2 | 1.4 | 1.8 | 2.4 | 3.0 | 3.2 | 5.0 |
| DOPPLER_HZ | 0.0 | 0.0 | 0.0 | 0.0 | 0.0 | 0.0 | 0.0 | 0.0 | 0.0 | 0.0 | 0.0 | 0.0 |
| ATTEN_DB | 4.0 | 3.0 | 0.0 | 2.0 | 3.0 | 5.0 | 7.0 | 5.0 | 6.0 | 9.0 | 11.0 | 10.0 |
| CORRELATION | 0.0 | 0.0 | 0.0 | 0.0 | 0.0 | 0.0 | 0.0 | 0.0 | 0.0 | 0.0 | 0.0 | 0.0 |

Profile #10 TITLE - "GSM/PCN BUx Bad Urban, 12-tap setting"

| SPECTRUM | RAY | RAY | RAY | RAY | RAY | RAY | RAY | RAY | RAY | RAY | RAY | RAY |
|-------------|-----|-----|-----|-----|-----|-----|-----|-----|-----|-----|------|------|
| DELAY_US | 0.0 | 0.2 | 0.4 | 0.8 | 1.6 | 2.2 | 3.2 | 5.0 | 6.0 | 7.2 | 8.2 | 10.0 |
| DOPPLER_HZ | 0.0 | 0.0 | 0.0 | 0.0 | 0.0 | 0.0 | 0.0 | 0.0 | 0.0 | 0.0 | 0.0 | 0.0 |
| ATTEN_DB | 7.0 | 3.0 | 1.0 | 0.0 | 2.0 | 6.0 | 7.0 | 1.0 | 2.0 | 7.0 | 10.0 | 15.0 |
| CORRELATION | 0.0 | 0.0 | 0.0 | 0.0 | 0.0 | 0.0 | 0.0 | 0.0 | 0.0 | 0.0 | 0.0 | 0.0 |

Dynamic ASCII Data File

Introduction

This appendix provides a description of the format for the input .ASC file to be used by the utility ASCI2DAT.EXE. This .ASC file, along with the presently defined SYSTEM.CFG and hardware configuration files is used by the ASCI2DAT translation to build a .DAT file used to control the HP 11759 Simulator in the Dynamic/Travel Test modes.

Field command format requirements for Dynamic/Travel Test .ASC files are as follows:

| | |
|----------|--|
| Comments | Comments in the Header portion of the file, prior to the hardware data settings, can be on a line starting with a COMMENTS: field name, or a line beginning with a "#" character. |
| FILEID: | Set this field argument to "ASCII" for this file. |
| | The Header portion of the file is identical to that described in Appendix E for the .DAT file format. |
| DATA: | This field name marks the end of the Header, control data follows. |
| | The DATA section of the ASCII format file contains the simulation settings which are to be sent to the hardware during a real time simulation. At each time interval, a group of data settings (a frame) is sent to the hardware. A series of settings is broken up into groups with the "SAMPLE:" key entry. |
| | Some general comments for each of the parameters in the DATA section are as follows: |
| | <ul style="list-style-type: none"> ■ Comments can be on a line starting with a "COMMENTS:" field, or following the character "#" located anywhere within the line. ■ Limit checking compares all of the specified hardware settings in the DATA portion of the file against the current hardware configuration file (as specified by the model number in the CHANSIM configuration menu) at the time of translation. If there is a contradiction between the allowable hardware limits and the user's specifications, a warning or error message will be produced. |

- One way to avoid setting/configuration errors is to view the hardware configuration file and the allowable settings. This can be done a with the following steps:
 1. Determine the instrument type associated with the path to be controlled for a simulation. Enter the CHANSIM configuration menu,
 2. The following is always true: Unit #1 is always associated with paths one through six. Unit #2 is always associated with paths 7 through 12 if a second instrument is configured.
 3. Tab the cursor in the Configuration menu to the "Model" entry listing the selected configuration file name. Take note of the model number displayed, and then press ENTER to see a list of all the model number configuration files available.
 4. Find the previously remembered model number under the Description column of the hardware configuration file choice menu. Take note of the File Name for that model number, which appears in the first column.
 5. Exit the Configuration menu by pressing the ESCAPE key repeatedly (even to the yes/no questions) and return to the main CHANSIM menu. Then press "Q" to quit and return to DOS.
 6. Type the following to see the hardware configuration files: "MORE < HwConfigFileName" where the actual file name is typed in place of "HwConfigFileName". For example, if the hardware configuration file name was HW0001.CFG, the user would type:

MORE < HW0001.CFG.

Press the Space Bar to page through the file. Press Ctl-C to stop viewing the file at any time.

The following limits are applied to a path unless a subset of them is specified in the Header of the .ASC file.

- No setting is ever allowed for a path that is declared OFF. A path is considered OFF if it has the SPECTRUM entry "OFF", or if no spectrum declaration line ever appears in the file for that path. Errors are generated when any setting is attempted for an OFF path.
- If no entry is specified for a path declared to be "on" in either DOPPLER or PHASE spectrum mode, the path will default to values of 50 dB attenuation, 0 usec of delay and either a 0 Hz Doppler frequency or 0 degrees phase (I=2047 and Q=0 for I/Q).

<path>:A: <Atten_dB> Specifies the dB attenuation level for path <path>. Attenuation may be set between the values of 0 and 50 dB inclusive.

<path>:D:<Delay_us> Specifies the amount of delay added to a path <path>. Delay is specified in microseconds, not seconds. Delay limits are a function of the type of delay mode which was chosen with the path's Header entry for DELAY TYPE.

- CLOCK mode delay limits are dependent upon the FIFO depth (given by FIFO NOMINAL or the hardware configuration file) and the delay clock range (given by the DELAY CLOCK MAX and DELAY CLOCK MIN fields or the hardware configuration file). For the default 4 kbyte FIFO, and a 22 to 28 MHz delay clock range, the maximum limit is:

$$\frac{4096}{22E^6 Hz} - \frac{4096}{28E^6 Hz} = 39.8961usec$$

- DEPTH delay mode limits are dependent upon the largest FIFO depth available and the nominal FIFO clocking (delay clock) frequency. Both of these factors are derived from the hardware configuration file for each channel in the HP 11759. For the default 4 kbyte FIFO and 22 MHz nominal clock, the maximum limit is:

$$\frac{4096}{22E^6 Hz} = 186.2usec$$

- HIRES delay mode limitations are identical to those listed for DEPTH delay mode. See the above paragraph for details.

<path>:F:<DopFreq_Hz> This field gives the Doppler frequency shift for the path specified <path>. The limit is given in the chosen hardware configuration file for the HP 11759 in which the path resides. The standard limits are -425 to +425 Hz inclusive.

- Doppler settings may not be sent to a path whose Header SPECTRUM entry declares the path to be any mode other than DOPPLER.

<path>P:<Phase_Deg> This field specifies the degrees of allowable phase shift applied to the signal as it passes through a path. The limits are ± 360 degrees.

- Phase settings may not be sent to a path whose Header SPECTRUM entry declares the path to be any mode other than PHASE.

S: This field name marks where one frame of settings has ended and the next interval in time is to begin. If no settings appear between the two "Synchronize" entries, then no settings are sent for that particular time. It is also possible to send too many settings between sample entries. Under this error condition, all of the settings in the frame group cannot be programmed to the hardware in time to allow real time processing. If this occurs during Dynamic Test playback of a .DAT file, the UPDATE RATE entry in the Header should be reduced.

- These "wait" statements are repeated after each data frame until the end of a file.

Dynamic ASCII Data File Example

```

FILEID:      ASCII # HP 11759 (C | D) Dynamic ascii data file.
REV:         1.00 # The FILEID must be first line of the file.
TITLE:       "Sample file for dynamic test" # Title limited to 28 characters
COMMENT:     This is a sample of the ascii file format which is usually
COMMENT:     created by a BASIC program or other program, and applied to
COMMENT:     the asci2dat.exe translator to create a .DAT file. The .DAT
COMMENT:     file is then read by the HP 11759C/D Dynamic test to run a
COMMENT:     simulation.
NPATHS:      6
NFRAMES:     3 # Run asci2dat on file to get number of frames.
UPDATE RATE: 10 # Each group of parameters are set at 10 Hz rate
# -----
# Define which paths will be on, and which types they are.
#
1:SPECTRUM:  DOPPLER # Path 1 set to Doppler mode. Path 1 = 1st path
2:SPECTRUM:  DOPPLER # in the HP 11759. Path 2 = Doppler too.
3:SPECTRUM:  OFF # Path 3 is explicitly shut off for simulation.
# Note that file 4 is left off; so it is NOT settable.
5:SPECTRUM:  PHASE # Path 5 is set to PHASE mode.
# -----
# Now define the delay types - -
#
1:DELAY TYPE: CLOCK # Delay is accomplished by varying a FIFO delay
2:DELAY TYPE: CLOCK # clock frequency between two limits.
# Path 3 is not specified, since it is OFF.
# 4 is off, so it isn't used at all here.
5:DELAY TYPE:  HIRES # Same as depth mode, but clock is tweaked too.
# -----
# Set phase, and also set the RF & LO so that phase may be accurately set on
# path two in the presence of an entered microseconds delay setting. The
# LO frequency is only needed for precise setting of phase on the path. Setting
# any path in one channel is equivalent to setting the frequencies for _all_
# paths in the channel. Since the HP 11759 paths are arranged by channels,
# all paths of the same channel must have the same RF and LO frequency.
#
5:RF FREQ:   900E+6 # Set RF frequency to 900 MHz, note value is in Hz.
5:LO FREQ:   906E+6 # This sets up a negative 6 MHz "IF" frequency
# -----
# Now define where the data begins.
#
DATA: # Marks the end of the header. Data follows.
# -----
# Now the data begins. Although spaces are shown between the second colon and
# the parameter, it is usually best to place the number next to the second
# colon. This saves space in the file, as would the removal of # comments.
# The data is organized into groups, called frames. The frame of parameters
# are all sent to the hardware as quickly as possible, and then the HP 11759

```

```
# waits some amount of time (the "update rate") before sending out the next
# frame.
#
1:A:      5          # Path 1 attenuation of 5 dB
1:D:     10          # Path 1 delay of 10 usec
1:F:     20          # Path 1 Doppler Frequency set to 20 Hz
2:A:      6          # Path 2 Attenuation set to 6 dB
2:D:     11          # Path 2 Delay is 11 usec
2:F:     21          # Path 2 Doppler frequency is 21 Hz
5:A:     13          # Path 5 Attenuation is 13 dB
5:D:     14          # Path 5 Delay set to 14 usec.
5:P:     30          # Path 5 phase is set to 30 degrees and left there.
S:        # ----- End of 1st Frame, wait for next interval-----
1:A:      5
1:D:     10
1:F:     20
2:A:      6
2:D:     11
2:F:     21
5:A:     13
5:D:     14
S:
1:A:      5
1:D:     10
1:F:     20
2:A:      6
2:D:     11
2:F:     21
5:A:     13
5:D:     14
S:
1:A:      5
1:D:     10
1:F:     20
2:A:      6
2:D:     11
2:F:     21
5:A:     13
5:D:     14
```

Translation Utility Data File

Introduction

This appendix provides a description of the format for the .DAT file created by the translation utility ASCI2DAT.EXE. This .DAT file, along with the presently defined SYSTEM.CFG and hardware configuration files is used to control the HP 11759 Simulator in the Dynamic/Travel Test modes.

The .DAT file header contains the following information:

| | |
|---------------------------|--|
| FILEID: | Set to DYNAMIC for this file. |
| REV: | The revision number is a float that begins at 1.00 and is increased as each revision is made. <ul style="list-style-type: none"> ■ Ignored by ASCI2DAT translator ■ Required to match the Dynamic/Travel Test format revision. |
| TITLE: <string> | Specifies the file's title. The string <string> must be enclosed in double quotes. <ul style="list-style-type: none"> ■ The ASCI2DAT translator copies any existing title to the .DAT file. ■ ASCI2DAT creates a title if the translated .ASC file had no title. ■ Displayed by the Dynamic/Travel Test file browsers. |
| COMMENT: <CommentText> | Up to 5 comment lines may be included as input to the .DAT file to document specific information for the file. The text need not be double quoted. <ul style="list-style-type: none"> ■ The ASCI2DAT translator copies the comments to the .DAT file only if they exist in the .ASC file. ■ The comments are not used at all by the Dynamic/Travel Tests. |
| NPATHS: <Npaths> | The number of paths in this file is an integer from 1 to 12. This should be the number of defined paths, counting OFF paths. (For example: If paths 1 and 3 are on, and path 2 is OFF, then the number of paths is 3 (1,2 and 3)). <ul style="list-style-type: none"> ■ It is created by ASCI2DAT from SPECTRUM calls or used as a new limit if already present in the .ASC file. |

UPDATE RATE:
<UpdateRateHz>

- Dynamic/Travel Tests check its value against the number of configured paths to see if the system configuration can support Npaths. This is required; if missing or =0, the SPECTRUM line with the largest path number assignment will define the number of paths.

The number of times a set of data (located after the DATA: keyword in the .DAT file) is sent to the hardware to be output per second.

- The ASCII2DAT translator assumes the travel test default of 10 Hz unless overridden with this entry.
- The Dynamic/Travel Test sets the frame timer to this rate, so outputs to the hardware are timed and occur at the specified update rate.
- An update rate should be 10 Hz or less if data is to be read from the hard disk.
- For update rates greater than 100 Hz, the .DAT file should be read from the RAM disk. See Chapter 3, Dynamic Test for details.

NFRAMES:
<NumOfFrames>

The number of time intervals of hardware settings in the file. If this field name is omitted, the HP 11759 software will count the number of time intervals (indicated by the "S:" wait statements) before running the simulation. This value is used to derive the "Percent Downloaded" indicator in the lower right corner of the Dynamic Test status display.

- The ASCII2DAT translator passes this values along to the .DAT file without any check. If the field name is missing, the system will not produce a warning because the number of frames will be counted by the Dynamic Test.
- The Dynamic Test uses the user-specified value (if it is given) to compute the Percent Downloaded. If the field is missing, it will take the system some small amount of time to go through thee and count the number of wait statements in the file.

<path>:SPECTRUM:
<type>

Specifies the spectral mode in which the path will operate. It is an unquoted string with no spaces. The three spectral modes of operation are OFF, DOPPLER and PHASE.

- OFF provides minimum signal leakage through a path when it is not used.

- DOPPLER turns the path on, and allows a constant Doppler shift to be added to the signal through that path.
- PHASE turns the path on, and allows a constant phase shift to be added to the signal through that path.

The spectrum type is handled as follows:

- The ASCII2DAT translator prevents the usage of inconsistent settings.
- No settings are sent to OFF paths.
- No degrees of phase settings are sent to DOPPLER paths.
- No Doppler frequency shifts are sent to PHASE paths.
- The Dynamic/Travel Test sets up the path as called out by the path spectrum type.

<path>:DELAY
TYPE:<type>

Specifies how the path FIFO is changed to create delay in the path. This is an unquoted string; the available delay modes are DEPTH, HIRES and CLOCK.

- DEPTH: The FIFO is STOPPED, the depth of the FIFO is changed, and then the processing through the FIFO is restarted again. Path signal flow is momentarily interrupted while the depth is changed, so this mode should only be used in the Header as a set-up command.
- HIRES: Same as DEPTH mode, except that the FIFO clock is skewed slightly to set delay with a higher resolution. Path signal flow is also momentarily interrupted while the depth of the FIFO is changed, so this mode should also only be used in the Header as a set-up command.
- CLOCK: The FIFO clock is changed between its maximum and nominal values to vary the delay through a path.

<path>:FIFO DEPTH:
<NomDepth>

The depth used to set the FIFO so clocking between a delay's nominal and maximum clock frequencies will achieve the requested delay. The default is what is listed in the hardware configuration file when the ASCII2DAT translation is run. The delay maximum and nominal clocks are taken from the hardware configuration file if the DELAY CLOCK entries are not in the Header.

- The ASCII2DAT translator computes the binary FIFO clock control words using the set depth and nominal and maximum clock settings.
- The translator will produce an error if the .ASC file calls out a NomDpeth that is larger than the current model number's hardware configuration file will allow.
- Both the Dynamic and Travel Tests uses the nominal depth of the FIFO and the nominal and maximum FIFO clock settings to set delay instead of the values specified in the hardware configuration file.

<path>:DELAY
CLOCK MAX:<freq>

The maximum delay clock is a floating point numeric. It is the maximum delay clock of the HP 11759 configuration available when that file was built (specified in Hz).

<path>:DELAY
CLOCK NOM:<freq>

The nominal delay clock is a floating point numeric. It is the nominal delay clock of HP 11759 when the .DAT file was built (specified in Hz).

<path>:RF FREQ:
<freq>

This is a floating point numeric that specifies the RF frequency in Hz. If the RF frequency is specified, then the LO frequency must also be given. These frequencies should be listed with precision to within 100 Hz

- The ASCII2DAT translator computes the tuning hardware control word by knowing the difference between the RF and LO frequencies (RF-LO) at a set usec delay.
- The Dynamic Test does not use the RF frequency setting at all.
- The Travel Test converts kmh to Hz of Doppler during the building of the .DAT files.

<path>:LO FREQ:
<freq>

This is a double that specifies the RF frequency in Hz. If the LO frequency is specified, then the RF frequency must also be given.

- The ASCII2DAT translator computes the tuning hardware control word by knowing the difference between the RF and LO frequencies (RF-LO) at a set usec delay.
- Both the Dynamic and Travel Tests do not use the LO frequency setting at all.

DATA:

Marks the end of the Header, data follows. The file entries before the DATA: entry may be in any order. The entries are required unless indicated otherwise.

- **HARDWARE BINARY DATA:** The binary values which are actually sent to the hardware follows the DATA: field name. This section of the file contains a binary description of the attenuation, Doppler or phase and delay hardware settings for each path.

Hardware Configuration File

Introduction

This appendix provides a description of the Hardware Configuration File (HWCONFIG) used by the System Configuration file. This information is provided for reference only, and should not be edited outside of the factory.

A set of descriptions of each field name and its usage for Hardware Configuration files. The key words used in the file along with their default values are given below. In parsing the values from the Configuration file, the key word must begin the line, followed by a colon. Next, there may be any number of spaces or tabs in any combination before the data is located, because spaces and tabs are ignored by the system.

| | |
|--------------|--|
| FILEID: | Identifies the type of HP 11759 file with an unquoted string. HWCONFIG designates the Hardware Configuration file. |
| REV: | The revision number is a float that begins at 1.0 and is increased as each new revision is made. |
| MODEL: | A quoted string representing the model type, 40 characters maximum are allowed. |
| HWCONFIG_ID: | The configuration identifier for the hardware is an integer index that is incremented as new configuration types are defined. |
| NPATHS: | The number of paths in the instrument. |
| NCHANS: | The number of channels in the instrument. |
| FIFO_MAX: | The maximum FIFO depth allowed for the instrument. |
| DOPPLER_MAX: | The maximum static Doppler frequency allowed by the system in Hz. |
| PERSONALITY: | The personality of the HP 11759. This would be "VIDEO" for an HP 11759D and "MOBILE" for an HP 11759C. This is an unquoted string. |
| DCLOCK_MIN: | The minimum startup default, hardware settable value for the delay FIFO's sample clock, in Hz. |
| DCLOCK_MAX: | The maximum startup default, hardware settable value for the delay FIFO's sample clock, in Hz. Do not exceed 28 Hz, this could cause damage to the instrument. |

| | |
|--------------|--|
| DCLOCK_NOM: | The nominal startup default, hardware settable value for the delay FIFO's sample clock, in Hz. |
| RFREQ_MAX: | The maximum allowable RF frequency in Hz. |
| RFREQ_MIN: | The minimum allowable RF frequency in Hz. |
| IFREQ_MAX: | The maximum allowable IF frequency in Hz. |
| IFREQ_MIN: | The maximum allowable IF frequency in Hz. |
| ATTEN_MAX: | The maximum allowable attenuation in dB. |
| ATTEN_MIN: | The minimum allowable attenuation in dB. |
| HWUPDAT_MAX: | The maximum allowable hardware update rate in Hz. |
| HWUPDAT_MIN: | The minimum allowable hardware update rate in Hz. |
| PHASE_MAX: | The maximum allowable static phase setting in degrees. |
| PHASE_MIN: | The minimum allowable static phase setting in degrees. |
| DOPCLK_DIV: | The dividing factor applied to the 10 MHz reference to get the internal Doppler DDS (Direct Dial Synthesis) clock. (For example: $10 \text{ MHz} / 596 = 16,666.66 \text{ Hz}$). This factor is extremely critical, and should not be edited outside of the factory. An incorrect adjustment could result in complete miscalibration of the system. |

Error Message Listings

Introduction

This appendix provides a description of the error messages that may be generated during operation of the Simulation software. The number printed after the error message indicates the “type” of error, categorized by the location where it occurred in the translation/simulation process.

For example:

ERROR: A “F” Doppler setting was attempted on a non-Doppler path.

Error was noticed at line #46 of the input file (ERROR 20).

Line: “3:F:30”

Translation terminated in an incomplete state (9).

The category number is 9, meaning that the error occurred during the translation and generation of the data portion of the .DAT file. The error identification number is 20: ERROR_NOT_DOP - A Doppler setting was attempted on a non-Doppler path.

Category of Error

1. Parse of the command line options.
2. Input .ASC file open.
3. Output .DAT file open.
4. Reading of hardware configuration file.
5. Parse Header of ASCII file.
6. Checking Hardware Configuration file.
7. Writing of header to .DAT file.
8. Reopening of .DAT file in Binary mode.
9. Translation and generation of .DAT “DATA” section.

Specific Parsing Error Message Numbers Parsing error numbers and descriptions are listed in the table that follows.

| Error | Number | Description |
|---------------------|--------|---|
| ERROR_WARNING | -1 | No error, warning only. |
| ERROR_NO_ERROR | 0 | Zero is defined as "no error found." |
| ERROR_TOO_LARGE | 1 | Numeric was too large. |
| ERROR_TOO_SMALL | 2 | Numeric was too small. |
| ERROR_NO_ARG | 3 | Missing numeric. |
| ERROR_NO_TOKEN | 4 | Flag that no token was found. |
| ERROR_NO_NREVS | 5 | Flag that too many rev nums were found. |
| ERROR_FILED1ST | 6 | File id record wasn't first line. |
| ERROR_NO_LEADQUOTE | 7 | Title is missing the leading quote. |
| ERROR_NUMTCHAR | 8 | Num Title Chars too high in title |
| ERROR_NO_TRAILQUOTE | 9 | Missing the trailing double quote in title |
| ERROR_NO_NTITLES | 10 | Then err out, only one rev rec allowed |
| ERROR_NO_NCOMMS | 11 | Then err out, only 5 comments allowed. |
| ERROR_NUMCCHAR | 12 | NumCommentChars too many in comment. |
| ERROR_NOPATHARG | 13 | Missing a numeric path argument. |
| ERROR_NO_SPECT | 14 | Error, no SPECTRUM records found. |
| ERROR_MAX_PATH | 15 | Spectrum path number is too high. |
| ERROR_NPATH_RECS | 16 | Too many NPATH rec entries found. |
| ERROR_NUM_UPRATE | 17 | Then err, only one update rate allowed. |
| ERROR_NUM_RECORDS | 18 | Then err out, only N rec allowed. |
| ERROR_PATHOFF | 19 | A param setting attempted on OFF path. |
| ERROR_NOT_DOP | 20 | A setting was attempted on non DOPPLER path |
| ERROR_NOT_PHASE | 21 | A Setting was tried on non PHASE path. |
| ERROR_ENDOF_FILE | 22 | Reach end of file when writing to .DAT file |
| ERROR_UNKNOWNTOK | 23 | Don't know what type of token was parsed. |
| ERROR_NO_REV | 24 | No Revision ID record was found in the file |
| ERROR_GOTPATHARG | 25 | Unexpected path argument found on line. |
| ERROR_BAD_REV | 26 | Illegal revision numeric in file. |
| ERROR_NO_MEM | 27 | Not enough memory to run the translation. |
| ERROR_NO_DATA | 28 | Missing a DATA statement before EOF reached |
| ERROR_DAT_1ST | 29 | Got parameter data record before DATA: rec. |
| ERROR_HWRITEBAD | 30 | .DAT Hdr Write error, probably at EndOfFile |
| ERROR_BINARYOPEN | 31 | Couldn't re-open .DAT in binary mode. |
| ERROR_DECLARDAT | 32 | A .dat Header cmd was attempted after DATA: |
| ERROR_BAD_DELIM | 33 | The token wasn't delimited properly w/'?:'. |

Index

- Special characters** #, 3-25
- 1** 12-Month Cleaning, 8-40
- 6** 6-Month Cleaning, 8-39
- A** A, 3-25
 - A10 Up Converter PCA (STD/OPT 002) Replacement, 8-31
 - A11 Down Converter PCA (OPT 001/003 ONLY) Replacement, 8-33
 - A11 Down Converter PCA (STD/OPT 002) Replacement, 8-32
 - A12 Up Converter PCA (OPT 001/003 ONLY) Replacement, 8-35
 - A12 Up Converter PCA (STD/OPT 002) Replacement, 8-34
 - A13 Clock/Divider PCA Replacement, 8-36
 - A14 Power Supply Replacement, 8-38
 - A1 Path Assembly Replacement, 8-22
 - A2 Path Assembly Replacement, 8-20
 - A3 Path Assembly Replacement, 8-18
 - A4 Path Assembly Replacement, 8-28
 - A5 Path Assembly Replacement, 8-26
 - A6 Path Assembly Replacement, 8-24
 - A7/A8 Synchronizer PCA Replacement, 8-16
 - A9 Down Converter PCA (STD/OPT 002) Replacement, 8-30
 - Abbreviated Commands, 3-46
 - Abbreviations, 6-1, 6-2, 6-3
 - Accessories, 1-6, A-4
 - Adjacent-Channel Testing, 3-6
 - Adjustment Locations, 8-3
 - Adjustments, 5-1
 - After Service Safety Checks, 8-2
 - Aids
 - Service, 8-3
 - .ASC File Line Format Requirements, 3-26
 - ASCII2DAT.EXE, D-1, E-1
 - ASCII.ASC file to Dynamic Test .DAT file Translation, 3-32
 - ASCII Data File, D-1
 - ASCII Data File Example, D-5
 - Assembly Locations, 8-3
 - Assembly Verification Procedures, 8-9
 - atten, 3-55
 - ATTEN, 3-84
 - ATTEN?, 3-84
 - ATTEN_MAX, F-2
 - ATTEN_MIN, F-2
 - ATTenuation, 3-55

ATTenuation?, 3-57
Attenuation Box, 3-12
Auxiliary LO Output Connectors, 3-3

B Basename, 3-42
Bottom Cover Removal, 8-15

C Cable
 Centronics Interface, 1-7
 Power, 1-6, 2-3
Cable Locations, 8-3
CATalog?, 3-51
Centronics Interface Cable, 1-7
Changes, 1-5
Channel Box, 3-9
Channel Options, 1-6
Channel Simulation Software, 1-6
Characteristics, A-1
Characteristics of Operation
 Dynamic Test, 3-27
Cleaning
 Intervals, 8-39
 Solution, 8-39
Clock, 3-30
Clock/Divider PCA Replacement, 8-36
Clock/Divider Verification, 8-11
*CLS, 3-80
Co-Channel Testing, 3-6
Command
 ATTEN, 3-84
 ATTenuation, 3-55
 *CLS, 3-80
 CORRelation, 3-70
 CORRELATION, 3-84
 CORRelation MODE, 3-71
 DELay, 3-58
 DELAY, 3-84
 DELay RESolution, 3-59
 DOPPLER, 3-84
 DOPpler FREquency, 3-62
 EXIT, 3-83, 3-84
 LOAD STATE, 3-51
 LOAD TRACe, 3-53
 LO FREquency, 3-64
 MENU SIMULATION/GHOST, 3-83
 MENU TRAVEL, 3-83
 NAME, 3-49
 *OPC, 3-80
 PATH, 3-84
 PHASe ADJust, 3-68
 PRESet, 3-78
 RAYLeigh FILEname, 3-74
 RESET, 3-84
 RF FREquency, 3-66

- *SAV, 3-80
- SPECTRUM, 3-84
- SPECTrum TYPE, 3-76
- SRECALL, 3-84
- STATe, 3-50
- STORe STATe, 3-54
- URECALL, 3-84
- USAVE, 3-84
- Command Format, 3-45
- Command Separator, 3-46
- Command Types, 3-45
- COMMENT, 3-25, E-1
- Common Commands, 3-80
- Configuration, 1-4
- Configuration Compatibility, 3-35
- Configuration File, F-1
- Connections, 3-2
- Connector Options, 1-6
- Connectors, 2-4
- Controller Requirements, 1-4
- correl, 3-70
- CORRelation, 3-70
 - MODE, 3-71
 - MODE?, 3-72
- CORRELATION, 3-84
- CORRelation?, 3-73
- CORRELATION?, 3-84
- Correlations Box, 3-13
- Cover Replacement, 8-15

D

- D, 3-25
- DATA, 3-25, D-1, E-5
- Datacom Configuration, 2-11
- DCLOCK_MAX, F-1
- DCLOCK_MIN, F-1
- DCLOCK_NOM, F-2
- Default, 3-42
- Default Parameters, 2-12
- DElay, 3-58
 - RESolution, 3-59
 - RESolution?, 3-60
- DELAY, 3-84
- DElay?, 3-61
- DELAY?, 3-84
- Delay Box, 3-12
- DELAY CLOCK NOM, E-4
- Delay Resolution, 3-12
- DELAY TYPE, E-3
- Depth, 3-30
- DEPTH, E-3
- Description
 - Channel Simulator, 1-3
 - Dynamic Test, 3-23
 - HP 11759C Channel Simulator, 1-3

- HP 11759C RF Channel Simulator, 1-1
- IQMAKE, 3-41
- Manual, 1-1
- Operating Principles, 8-4
- Operation, 3-1
- SCPI Commands, 3-45
- Travel Test, 3-15
- Verification Check, 2-14
- Descriptions
 - Adjustments, 5-1
 - Determining The Failure Mode, 8-7
 - Disabling a Path, 3-14
 - Discrete Parameters, 3-48
 - Diversity Systems, 3-6
 - DOPCLK_DIV, F-2
 - Doppler, 3-29
 - DOPPLer
 - FREQuency, 3-62
 - FREQuency?, 3-63
 - DOPPLER, 3-84
 - DOPPLER?, 3-84
 - Doppler Box, 3-10
 - DOPPLER_MAX, F-1
 - Doppler Spectrum Mode, 3-8
 - Down Converter PCA (OPT 001/003 ONLY) Replacement, 8-33
 - Down Converter PCA (STD/OPT 002) Replacement, 8-30, 8-32
 - Down Converter Verification, 8-10
 - Dual Channel Option, 1-6
 - Duplex Testing, 3-6
 - Dynamic ASCII Data File Example, D-5
 - Dynamic Test, 3-23
 - Simulation, 3-36

E Electrostatic Discharge (ESD) Precautions, 8-14

- Environment
 - Operating, 2-4
 - Storage and Shipment, 2-18
- Environmental Characteristics, A-2
- ERRor?, 3-78
- Error Listing, G-1
- Error Messages, 3-88
- *ESR?, 3-80
- Example
 - Dynamic ASCII Data File, D-5
- Examples
 - Programming, B-1, B-7
- EXIT, 3-83, 3-84
- Exit Channel Simulation Test, 3-14

F F, 3-25
 Failure Mode, 8-7
 Fault Listing, G-1
 Features
 Panel, 3-1
 FIFO DEPTH, E-3
 FIFO_MAX, F-1
 File Format
 Dynamic Test, 3-23
 FILEID, 3-25, D-1, E-1, F-1
 filename, 3-53
 File Read, 3-42
 Flange Kit, 1-6
 frequency, 3-62, 3-64, 3-66
 FREQUENCY?, 3-84
 Front Panel Connections and Indications, 3-2
 Front Panel Connector Option, 1-6
 Front Panel Features, 3-1
 Fuse Replacement, 3-1
 Fuse Selection, 2-2

G Grounding, 2-1

H Handle Kit, 1-6
 Hardware Characteristics, 8-3
 Hardware Configuration File, F-1
 Hardware Malfunctions, 8-7
 Help, 3-43
 HIRES, 3-30
 HP-IB Command Format, 3-45
 HP-IB Command Types, 3-45
 HP-IB Interface Programming Example, B-7
 HP-IB Remote Operating Procedures, 3-45
 HWCONFIG_ID, F-1
 HWUPDAT_MAX, F-2
 HWUPDAT_MIN, F-2

I IDENTIFY?, 3-83, 3-84
 *IDN?, 3-80
 IFREQ_MAX, F-2
 IFREQ_MIN, F-2
 Implied Commands, 3-46
 Indicators, 3-2
 Information
 Service, 8-3
 Initial Inspection, 2-1
 Input/Output Specifications, A-1
 Input Power, 2-1
 Inspection, 2-1
 Installation, 2-1
 Remote Control, 2-9
 Software, 2-6
 Instruments Covered By This Manual, 1-5

Interface Cable, 1-7
IQMAKE, 3-41

K K Points, 3-43

L Line Format Requirements, 3-26

Line Indicator, 3-2

Line Module, 3-4

Line-of-Sight Path, 3-19

Line Switch, 3-4

Line Voltage Selection, 2-2

LO

FREQ, E-4

FREQuency, 3-64

FREQuency?, 3-65

LOAD

STATe, 3-51

TRACe, 3-53

Local Operating Procedures, 3-5

Local Oscillator Requirements, 1-5

LO FREQ, 3-25

LO Input Connectors, 3-3

M Main Menu Word Commands, 3-83

Maintenance, 3-1, 8-39

Malfunctions, 8-7

Manual Changes Supplement, 1-5

Manual Description, 1-1

Mating Connectors, 2-4

MENU?, 3-83, 3-84

MENU SIMULATION/GHOST, 3-83

MENU TRAVEL, 3-83

Message

Error, G-1

Minimum System Configuration, 1-4

MMEMory Subsystem, 3-51

mode, 3-71

MODEL, F-1

Modifying the Travel Setup, 3-16

Multipliers, 6-3

N name, 3-74

NAME, 3-49

NAME?, 3-49

NCHANS, F-1

NFRAMES, 3-25, E-2

No Execution, 3-44

Notation, 3-82

NPATHS, 3-25, E-1, F-1

Numeric Parameters, 3-48

- O**
 - Off, 3-29
 - *OPC, 3-80
 - *OPC?, 3-80
 - Operating Characteristics, 3-1
 - Operating Environment, 2-4
 - Operating Instructions, 3-1
 - Operating Principles, 8-4
 - Operating Procedures, 3-5
 - HP-IB, 3-45
 - Serial, 3-81
 - Operation, 3-1
 - Operator's Maintenance, 3-1
 - Options, 1-5
 - Ordering Information, 6-1
 - Output Rate, 3-44
 - Overdrive LED Verification, 8-13
 - Overrange Indicator, 3-2

- P**
 - P, 3-25
 - Packaging, 2-18
 - Panel Features, 3-1
 - Parallel Printer Connector, 3-3
 - Parameters, 3-47
 - Parts, 6-1
 - Parts List Updating, 6-1
 - Parts Locations, 8-3
 - PATH, 3-84
 - PATH?, 3-84
 - Path Assembly Replacement, 8-18, 8-20, 8-22, 8-24, 8-26, 8-28
 - Paths, 3-44
 - Path Verification, 8-9
 - PC Interface Verification, 8-13
 - Performance Limits, A-1
 - Periodic Maintenance, 8-39
 - PERSONALITY, F-1
 - phase, 3-68
 - Phase, 3-29
 - PHASe
 - ADJust, 3-68
 - ADJust?, 3-69
 - Phase Box, 3-10
 - PHASE_MAX, F-2
 - PHASE_MIN, F-2
 - Phase Spectrum Mode, 3-9
 - Physical Characteristics, A-2
 - Power Cable, 1-6, 2-3
 - Power Requirement, 2-1
 - Power Supply Replacement, 8-38
 - Power Supply Verification, 8-12
 - Preparation for Use, 2-1
 - PRESet, 3-78
 - Principles of Operation, 8-4
 - Profiles, C-1
 - Programming

Single-key Command , 3-81
Word Command, 3-81
Programming Examples, B-1, B-7
program_name, 3-49
PROGram Subsystem, 3-49

Q Query

ATTEN?, 3-84
ATTenuation?, 3-57
CATalog?, 3-51
CORRelation?, 3-73
CORRELATION?, 3-84
CORRelation MODE?, 3-72
DELay?, 3-61
DELAY?, 3-84
DELay RESolution?, 3-60
DOPPLER?, 3-84
DOPPler FREQuency?, 3-63
ERRor?, 3-78
*ESR?, 3-80
FREQUENCY?, 3-84
IDENTIFY?, 3-83, 3-84
*IDN?, 3-80
LO FREQuency?, 3-65
MENU?, 3-83, 3-84
NAME?, 3-49
*OPC?, 3-80
PATH?, 3-84
PHASe ADJust?, 3-69
RAYLeigh FILEname?, 3-75
*RCL, 3-80
RF FREQuency?, 3-67
*RST, 3-80
SPECTRUM?, 3-84
SPECTrum TYPE?, 3-77
SPROFILE?, 3-84
*STB?, 3-80
*TST?, 3-80
UPROFILE?, 3-84
VERSion?, 3-79
*WAI, 3-80

R

Rack Mounting, 1-6
RAYLeigh
 FILEname, 3-74
 FILEname?, 3-75
Rayleigh Spectrum Mode, 3-8
*RCL, 3-80
Rear Panel Connections and Indications, 3-2
Rear Panel Connector Option, 1-6
Rear Panel Features, 3-1
Recommended Test Equipment, 1-7, A-4
Reference Designations, 6-2
Remote Commands

- Sending, 3-46
- Remote Control Installation, 2-9
- Remote Operating Procedures
 - HP-IB, 3-45
 - Serial, 3-81
- Remote Operation, 3-81
- Remove
 - Bottom Cover, 8-15
 - Top Cover, 8-14
- Repair, 8-14
- Repair Parts, 6-1
- Replace
 - A10 Up Converter PCA (STD/OPT 002), 8-31
 - A11 Down Converter PCA (OPT 001/003 ONLY), 8-33
 - A11 Down Converter PCA (STD/OPT 002), 8-32
 - A12 Up Converter PCA (OPT 001/003 ONLY), 8-35
 - A12 Up Converter PCA (STD/OPT 002), 8-34
 - A13 Clock/Divider PCA, 8-36
 - A14 Power Supply, 8-38
 - A1 Path Assembly, 8-22
 - A2 Path Assembly, 8-20
 - A3 Path Assembly, 8-18
 - A4 Path Assembly, 8-28
 - A5 Path Assembly, 8-26
 - A6 Path Assembly, 8-24
 - A7/A8 Synchronizer PCA, 8-16
 - A9 Down Converter PCA (STD/OPT 002), 8-30
 - Covers, 8-15
- Replaceable Parts, 6-1
- Requirements
 - Controller, 1-4
 - Local Oscillator, 1-5
- RESET, 3-84
- Reset Values, 3-14
- resol, 3-59
- REV, 3-25, E-1, F-1
- RF
 - FREQuency, 3-66
 - FREQuency?, 3-67
 - RF FREQ, 3-25, E-4
 - RF Input Connectors, 3-3, 3-4
 - RF Output Connectors, 3-3
 - RFREQ_MAX, F-2
 - RFREQ_MIN, F-2
 - *RST, 3-80

S S, 3-25
 Safety Checks, 8-2
 Safety Considerations, 1-5, 8-1
 *SAV, 3-80
 Saving Profiles, 3-14
 SCPI Command Format, 3-45
 SCPI Commands, 3-45
 Selection
 Fuse , 2-2
 Line Voltage, 2-2
 Sending Remote Commands, 3-46
 Serial, 3-82
 Separator, 3-46
 Serial Interface Programming Example, B-1
 Serial Prefix, 1-5
 Serial Remote Operating Procedures, 3-81
 Service Aids on Printed Circuit Boards, 8-3
 Service Documents, 8-4
 Service Information, 8-1
 Service Tools, Aids, and Information, 8-3
 Set-Up Procedures, 2-5
 Shipment, 2-18
 Signal Map, 3-15
 Simulation
 Dynamic Test, 3-36
 Simulation Software, 1-6
 Simulation Test Profiles, C-1
 Simulation Tests, 3-8
 Simulation Test Word Commands, 3-84
 Single Channel Option, 1-6
 Single-key Command Programming, 3-81
 Single-Key Commands, 3-87
 SMODifier Subsystem, 3-55
 Software, 1-6
 Removal, 2-8
 Software Errors, G-1
 Software Installation, 2-6
 Specifications, 1-3, A-1
 SPECTrum
 TYPE, 3-76
 TYPE?, 3-77
 SPECTRUM, 3-25, 3-84, E-2
 SPECTRUM?, 3-84
 Spectrum Box, 3-10
 Spectrum Mode
 Doppler, 3-8
 Phase, 3-9
 Rayleigh, 3-8
 SPROFILE?, 3-84
 SRECALL, 3-84
 Standard Profiles, C-1
 state, 3-50
 STATE, 3-50
 state_number, 3-51, 3-54
 state_title, 3-54

- state_type, 3-51
- *STB?, 3-80
- Storage, 2-18
- STORE
 - STATE, 3-54
- Subsystem Syntax, 3-49, 3-51, 3-55, 3-78
- Supplement, 1-5
- Supplemental Characteristics, A-2
- Synchronizer PCA Replacement, 8-16
- Synchronizer Verification, 8-10
- Syntax
 - Serial, 3-82
- System Configuration, 1-4
- System Configuration File, F-1
- SYSTEM Subsystem, 3-78
- System Verification Check, 2-14

T

- Terminal Configuration, 2-11
- Test Equipment, 1-7, A-4
- Test Point Locations, 8-3
- Theory of Operation, 8-4
- time, 3-58
- Timebase Input Connector, 3-4
- Title, 3-44
- TITLE, 3-25, E-1
- Tools
 - Service, 8-3
- Top Cover Removal, 8-14
- Translation of ASCII.ASC files to Dynamic Test .DAT files, 3-32
- Translation Utility, E-1
- Travel Test, 3-15
- Travel Test Word Commands, 3-87
- Troubleshooting, 8-7
- *TST?, 3-80
- Turn-On Procedures, 2-5
- type, 3-76
- Types of Parameters, 3-47

U

- Unconditional Build, 3-44
- Up Converter PCA (OPT 001/003 ONLY) Replacement, 8-35
- Up Converter PCA (STD/OPT 002) Replacement, 8-31, 8-34
- Up Converter Verification, 8-11
- Update Rate, 3-38
- UPDATE RATE, 3-25, E-2
- UPROFILE?, 3-84
- URECALL, 3-84
- USAVE, 3-84
- Use KMH, 3-44
- User Information, A-1

- V** Verification Check, 2-14
- Verification Procedures, 8-9
- Verify
 - Clock/Divider, 8-11
 - Down Converter, 8-10
 - Overdrive LED, 8-13
 - Path, 8-9
 - PC Interface, 8-13
 - Power Supply, 8-12
 - Synchronizer, 8-10
 - Up Converter, 8-11
- VERSiOn?, 3-79

- W** *WAI, 3-80
- Warning Messages, 3-88
- Word Commands, 3-81